

Gasoline Powered Pressure Washer

Item 67546
 (EPA version) 212cc engine

Item 67596
 (EPA/CARB version) 212cc engine



⚠ DANGER

Using an engine indoors **CAN KILL YOU IN MINUTES.**

Engine exhaust contains carbon monoxide. This is a poison you cannot see or smell.

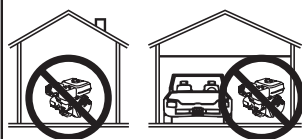

NEVER use inside a home or garage, **EVEN** IF doors and windows are open.

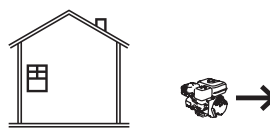

Only use **OUTSIDE** and far away from windows, doors, and vents.

⚠ WARNING

Read this material before using this product. Failure to do so can result in serious injury.
SAVE THIS MANUAL.

When unpacking, make sure that the product is intact and undamaged.
 If any Pressure Washer parts are missing or broken, please call 1-800-444-3353 as soon as possible.
 If any Engine parts are missing or broken, please call 1-800-520-0882 as soon as possible.

Visit our website at: <http://www.harborfreight.com>
 Email our tech support at: tech@harborfreight.com
 Email our Engine tech support at: predator@harborfreight.com

3 Specifications

3 Safety Warnings

- 4 Set up Precautions
- 4 Operating Precautions
- 5 Service Precautions

7 Set Up Instructions

- 7 Assembly

8 Engine Controls

- 8 Item 67546 (EPA version)
- 8 Item 67596 (EPA/CARB version)

9 Operating Instructions

- 9 Starting the Engine
- 11 Equipment Operation

13 Service

- 13 Maintenance Procedures
- 13 Cleaning, Maintenance, and Lubrication Schedule
- 15 Storage
- 16 Troubleshooting

18 Parts Lists and Diagrams

- 18 General Parts List
- 19 General Assembly Diagram
- 20 Parts List A - Pump
- 21 Assembly Diagram A - Pump
- 22 Parts List B - Engine - Item # 67546 (EPA version)
- 23 Assembly Diagram B - Engine - Item # 67546 (EPA version)
- 24 Parts List B - Engine - Item # 67596 (EPA/CARB version)
- 25 Assembly Diagram B - Engine - Item # 67596 (EPA/CARB version)

26 Warranties

- 26 Limited 90 Day Warranty
- 26 Emission Control System Warranty

Specifications

Displacement	212cc	
Engine Type	Predator OHV	
Pump	Brass Axial	
Drive	Direct	
Gun	22 IN. Wand / 20 IN. Lance	
Nozzles	Quick Connect 0°, 15°, 25°, 40° + Soap Nozzle	
Hose Length	26 FT. 7 IN.	
Cart	Push type with 10 IN. Pneumatic tires	
Fuel	Type	87+ octane unleaded gasoline
	Capacity	1 Gallon / 3.6L
Engine Oil (not included)	Type (SAE)	10W-30 above 32° F 5W-30 at 32° F or below
	Capacity	0.5 Quart / 0.5L
	Low Oil Shutdown	Yes
Pump Oil (included)	3.75 fl-oz SAE 10W-30 Non-detergent	
Engine Speed	3,600 RPM	
Water Flow	3 GPM Maximum	
Maximum Pressure	2,500 PSI	
Bore x Stroke	70 mm x 55 mm	
Compression Ratio	8.5:1	
Rotation viewed from PTO (power takeoff - the output shaft)	Counterclockwise	
Spark Plug	Type	NGK® BP-6ES NHSP® / Torch® F6TC
	Gap	0.7 - 0.8 mm
Valve Clearance	Intake	0.10 - 0.15 mm
	Exhaust	0.15 - 0.20 mm

Item 67546: The emission control system for this Pressure Washer's engine is warranted for standards set by the U.S. Environmental Protection Agency. For warranty information, refer to the last pages of this manual.

Item 67596: The emission control system for this Pressure Washer's Engine is warranted for standards set by the U.S. Environmental Protection Agency and by the California Air Resources Board (also known as CARB). For warranty information, refer to the last pages of this manual.

At high altitudes, the engine's carburetor, governor (if so equipped), and any other parts that control the fuel-air ratio will need to be adjusted by a qualified mechanic to allow efficient high-altitude use and to prevent damage to the engine and any other devices used with this product.

REV 11c

SKU 67546/67596 For Pressure Washer technical questions, please call 1-800-444-3353.
For Engine technical questions, please call 1-800-520-0882.

Save This Manual

Keep this manual for the safety warnings and precautions, assembly, operating, inspection, maintenance and cleaning procedures. Write the product's serial number in the back of the manual near the assembly diagram (or month and year of purchase if product has no number). Keep this manual and the receipt in a safe and dry place for future reference.

Safety Warnings

In this manual, on the labeling, and all other information provided with this product:



This is the safety alert symbol. It is used to alert you to potential personal injury hazards. Obey all safety messages that follow this symbol to avoid possible injury or death.

⚠ DANGER

DANGER indicates a hazardous situation which, if not avoided, will result in death or serious injury.

⚠ WARNING

WARNING indicates a hazardous situation which, if not avoided, could result in death or serious injury.

⚠ CAUTION

CAUTION, used with the safety alert symbol, indicates a hazardous situation which, if not avoided, could result in minor or moderate injury.

NOTICE

NOTICE is used to address practices not related to personal injury.

CAUTION

CAUTION, without the safety alert symbol, is used to address practices not related to personal injury.



WARNING! Read all instructions. Failure to follow all instructions listed below may result in fire, serious injury and/or DEATH.

The warnings and precautions discussed in this manual cannot cover all possible conditions and situations that may occur. It must be understood by the operator that common sense and caution are factors which cannot be built into this product, but must be supplied by the operator.



SAVE THESE INSTRUCTIONS.

Set up Precautions

1. Gasoline fuel and fumes are flammable, and potentially explosive. Use proper fuel storage and handling procedures. Do not store fuel or other flammable materials nearby.
2. Have multiple ABC class fire extinguishers nearby.
3. Operation of this equipment may create sparks that can start fires around dry vegetation. A spark arrestor may be required. The operator should contact local fire agencies for laws or regulations relating to fire prevention requirements.
4. Set up and use only on a flat, level, well-ventilated surface.
5. The work area should have adequate drainage to reduce the possibility of a fall due to slippery surfaces.
6. Wear ANSI-approved safety goggles, heavy-duty work gloves, and dust mask/respirator during set up and use.
7. Use only oil and fuel recommended in the "Specifications" section of this manual.
8. Only use cold Water or pressure washer detergent in this tool. Do not use caustic materials, solvents, flammable materials, or detergents not designed for pressure washers. Use of any such material can cause injury, or damage this tool or personal property.
9. Do not dry run this product. Dry running will cause serious damage to the seals. Make sure the water supply used for the Pressure Washer is not dirty or sandy.
10. Prior to starting the Pressure Washer in cold weather, check all of the parts of the unit to make sure ice has not formed. Do not store the unit anywhere that the temperature will fall below 32° F (0° C).

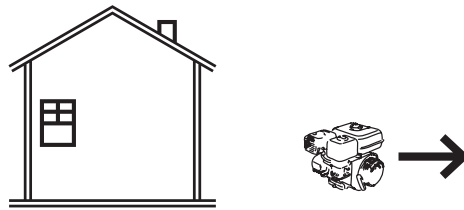

Only use OUTSIDE and far away from windows, doors, and vents.

2. Keep children away from the equipment, especially while it is operating.
3. Do not leave the equipment unattended when it is running. Turn off the equipment (and remove safety keys, if available) before leaving the work area.
4. Wear ANSI-approved safety goggles and hearing protection during use.
5. People with pacemakers should consult their physician(s) before use. Electromagnetic fields in close proximity to a heart pacemaker could cause pacemaker interference or pacemaker failure. Caution is necessary when near the engine's magneto or recoil starter.
6. Use only accessories that are recommended by Harbor Freight Tools for your model. Accessories that may be suitable for one piece of equipment may become hazardous when used on another one.
7. Do not operate in explosive atmospheres, such as in the presence of flammable liquids, gases, or dust. Gasoline-powered engines may ignite the dust or fumes.
8. Stay alert, watch what you are doing and use common sense when operating a piece of equipment. Do not use a piece of equipment while tired or under the influence of drugs, alcohol or medication.
9. Do not overreach. Keep proper footing and balance at all times. This enables better control of the equipment in unexpected situations.
10. Do not carry the spray handle with your finger on the trigger, whether engine is operating or not.
11. Use this equipment with both hands only. Using equipment with only one hand can easily result in loss of control.
12. Dress properly. Do not wear loose clothing or jewelry. Keep hair, clothing and gloves away from moving parts. Loose clothes, jewelry or long hair can be caught in moving parts.
13. Parts of the Pressure Washer, especially exhaust system components, get very hot during use. Stay clear of hot parts.

Operating Precautions

1.  **CARBON MONOXIDE HAZARD**
Using an engine indoors **CAN KILL YOU IN MINUTES.**
Engine exhaust contains carbon monoxide. This is a poison you cannot see or smell.

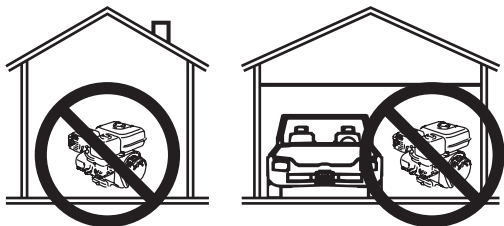

NEVER use inside a home or garage, EVEN IF doors and windows are open.

14. Do not cover the engine or equipment during operation.
15. Keep the equipment, engine, and surrounding area clean at all times.
16. Use the equipment, accessories, etc., in accordance with these instructions and in the manner intended for the particular type of equipment, taking into account the working conditions and the work to be performed. Use of the equipment for operations different from those intended could result in a hazardous situation.
17. Do not operate the equipment with known leaks in the engine's fuel system.
18. This product contains or, when used, produces a chemical known to the State of California to cause cancer and birth defects or other reproductive harm. (California Health & Safety Code § 25249.5, *et seq.*)
19. **WARNING:** The brass components of this product contain lead, a chemical known to the State of California to cause birth defects (or other reproductive harm). (California Health & Safety code § 25249.5, *et seq.*)
20. When spills of fuel or oil occur, they must be cleaned up immediately. Dispose of fluids and cleaning materials as per any local, state, or federal codes and regulations. Store oil rags in a bottom-ventilated, covered, metal container.
21. Keep hands and feet away from moving parts. Do not reach over or across equipment while operating.
22. Before use, check for misalignment or binding of moving parts, breakage of parts, and any other condition that may affect the equipment's operation. **If damaged, have the equipment serviced before use.** Many accidents are caused by poorly maintained equipment.
23. Use the correct equipment for the application. Do not modify the equipment and do not use the equipment for a purpose for which it is not intended.
24. The high pressure water flow can damage the work surface if not used properly. Always test the spray in an open area first.
25. When dispensing detergent, apply the detergent to the cleaning area at low pressure only. Detergent dispensing only works when the spray wand is in the low-pressure position.
26.  Injection Hazard. The high pressure water jet produced by this tool can cut skin or cause injury to hands or eyes. Do not allow spray to strike you and do not spray toward people or animals. Do not spray the tool itself or any electrical wiring/receptacle.
27. This Pressure Washer is intended for outdoor residential use only.
28. **In case of an emergency during use, immediately release the trigger on the spray handle, turn the engine off and then shut off gas supply to the engine. Do not set the spray handle down without turning off the engine.**

Vibration Hazard:

This tool vibrates during use. Repeated or long-term exposure to vibration may cause temporary or permanent physical injury, particularly to the hands, arms and shoulders. To reduce the risk of vibration-related injury:

1. Anyone using vibrating tools regularly or for an extended period should first be examined by a doctor and then have regular medical check-ups to ensure medical problems are not being caused or worsened from use. Pregnant women or people who have impaired blood circulation to the hand, past hand injuries, nervous system disorders, diabetes, or Raynaud's Disease should not use this tool. If you feel any medical or physical symptoms related to vibration (such as tingling, numbness, and white or blue fingers), seek medical advice as soon as possible.
2. Do not smoke during use. Nicotine reduces the blood supply to the hands and fingers, increasing the risk of vibration-related injury.
3. Wear suitable gloves to reduce the vibration effects on the user.
4. Use tools with the lowest vibration when there is a choice between different processes.
5. Include vibration-free periods each day of work.
6. Grip tool as lightly as possible (while still keeping safe control of it). Let the tool do the work.
7. To reduce vibration, maintain the tool as explained in this manual. If any abnormal vibration occurs, stop use immediately.

Service Precautions

1. **Before service, maintenance, or cleaning:**
 - a. **Turn the engine switch to its "OFF" position.**
 - b. **Allow the engine to completely cool.**
 - c. **Then, remove the spark plug wire(s) from the spark plug(s).**
2. Keep all safety guards in place and in proper working order. Safety guards include muffler, air cleaner, mechanical guards, and heat shields, among other guards.



SAVE THESE INSTRUCTIONS.

3. **Do not alter or adjust any part of the equipment or its engine that is sealed by the manufacturer or distributor. Only a qualified service technician may adjust parts that may increase or decrease governed engine speed.**
4. Wear ANSI-approved safety goggles, heavy-duty work gloves, and dust mask/respirator during use and service.
5. Keep the high pressure hose connected to the pressure washer and spray gun while the system is pressurized. Disconnecting the pressure hose while the unit is pressurized is dangerous, and may cause injury.
6. Do not allow the high pressure hose to come in contact with any hot part of the unit. The hose might be damaged, possibly causing it to burst or leak under high pressure.
7. Maintain labels and nameplates on the equipment. These carry important information. If unreadable or missing, contact Harbor Freight Tools for a replacement.
8. If water is leaking out of the Pressure Washer immediately turn off the unit. Unplug the Pressure Washer, and discharge all pressure before tightening fittings or having repair work done by a qualified technician.
9. When the engine is running, do not allow the Pressure Washer to remain idle for more than two minutes. If allowed to remain idle, the water in the unit will heat up, possibly causing damage to the Pressure Washer.
10. Have the equipment serviced by a qualified repair person using only identical replacement parts. This will ensure that the safety of the equipment is maintained. Do not attempt any service or maintenance procedures not explained in this manual or any procedures that you are uncertain about your ability to perform safely or correctly.
11. Store equipment out of the reach of children.
12. Follow scheduled engine and equipment maintenance.

Refueling:

1. Do not smoke, or allow sparks, flames, or other sources of ignition around the equipment, especially when refuelling.
2. Do not refill the fuel tank while the engine is running or hot.
3. Do not fill fuel tank to the top. Leave a little room for the fuel to expand as needed.
4. Refuel in a well-ventilated area only.

Set Up Instructions



Read the **ENTIRE IMPORTANT SAFETY INFORMATION** section at the beginning of this manual including all text under subheadings therein before set up or use of this product.

WARNING

Risk of accidental starting; resulting in serious personal injury. Turn the Power

Switch of the equipment to its "OFF" position, wait for the engine to cool, and unplug the spark plug wire(s) before assembling or making any adjustments to the equipment.

Note: For additional information regarding the parts listed in the following pages, refer to the Assembly Diagram near the end of this manual.

Assembly

1. Operation of this equipment may create sparks that can start fires around dry vegetation. A spark arrestor may be required. The operator should contact local fire agencies for laws or regulations relating to fire prevention requirements.

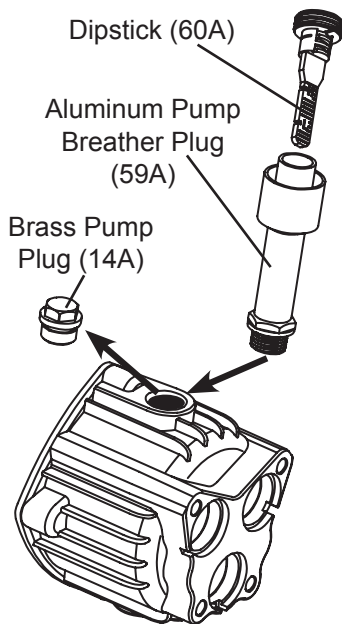

Figure 1

2. Replace the Brass Pump Plug (14A) with the aluminum Pump Breather Plug (59A) and Dipstick (60A) before first use. The Pump Breather Plug must be used whenever the pressure washer is used. The Brass Pump Plug (without the breather hole) should be used for transporting only.
3. Attach the Handle (14) onto the Frame (17) with the Handle Bolts (15) and Nuts (16).

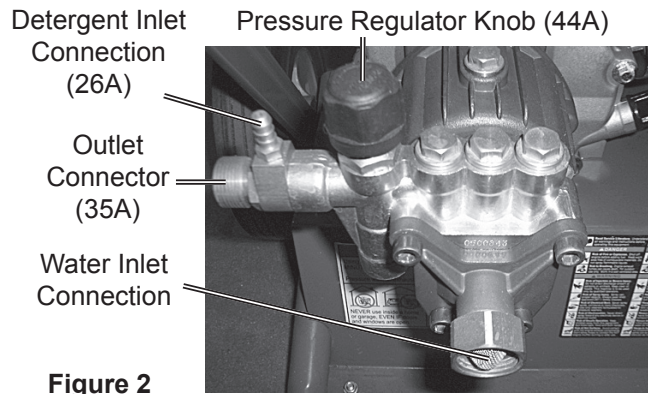

Figure 2

4. Attach the Hose (18) to the Outlet Connector (35A) on the unit (See Figure 2).
5. Pull the Collar at the end of the hose back and attach the Gun (19) to the hose.
6. Screw the Wand (20) onto the Gun (19) and secure with the grommet.
7. Choose the right Nozzle (5) for the job. Pull back the quick connect collar and push the Nozzle onto the end of the Wand. Make sure the quick connect collar locks the Nozzle in place.
 - **Black Nozzle - Low Pressure**
Used with pressure washer detergent.
 - **White Nozzle - Wide Spray**
Used to clean very large areas.
 - **Green Nozzle - Medium Spray**
Used to clean larger areas.
 - **Yellow Nozzle - Narrow Spray**
Used to clean small areas.
 - **Red Nozzle - Pencil Spray**
Only use on hard surfaces such as concrete or metal. Can damage wood.
8. Connect the water supply to the Water Inlet Connection on the Water Inlet Body (42A). The water source must be able to provide a minimum of five gallons of clean, cold water per minute at 20 PSI. Only use a 5/8" inner diameter (or larger) hose that is rated to meet this capacity.

If using detergent:

Read detergent directions. Connect one end of the Detergent Inlet Hose (8) to the Detergent Inlet Connection, and the other end into the container holding the detergent. Only use detergents specified for use with Pressure Washers. The Pressure Washer will draw one gallon of detergent for every seven gallons of water. Only use the Black (low pressure) Nozzle when spraying detergents.

Engine Controls

Item 67546 (EPA version)

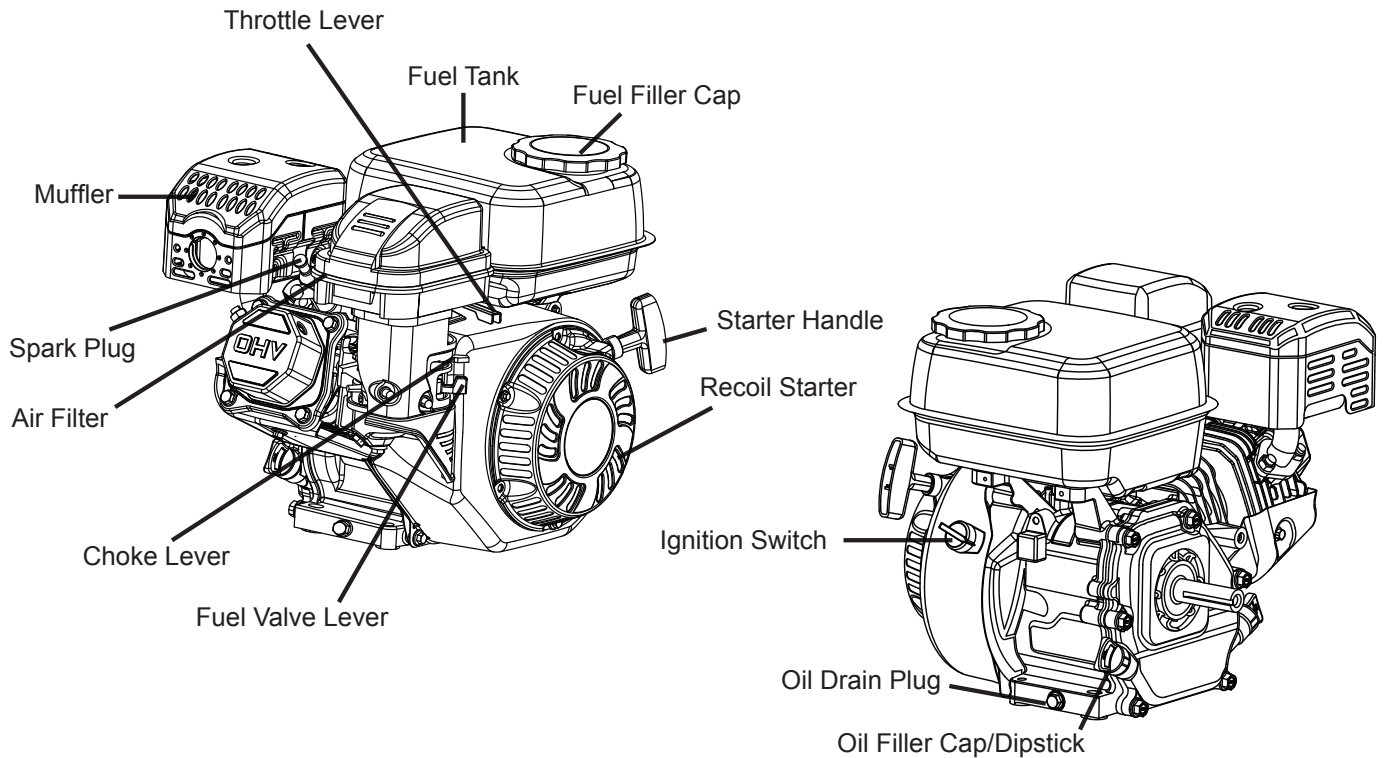

Item 67596 (EPA/CARB version)

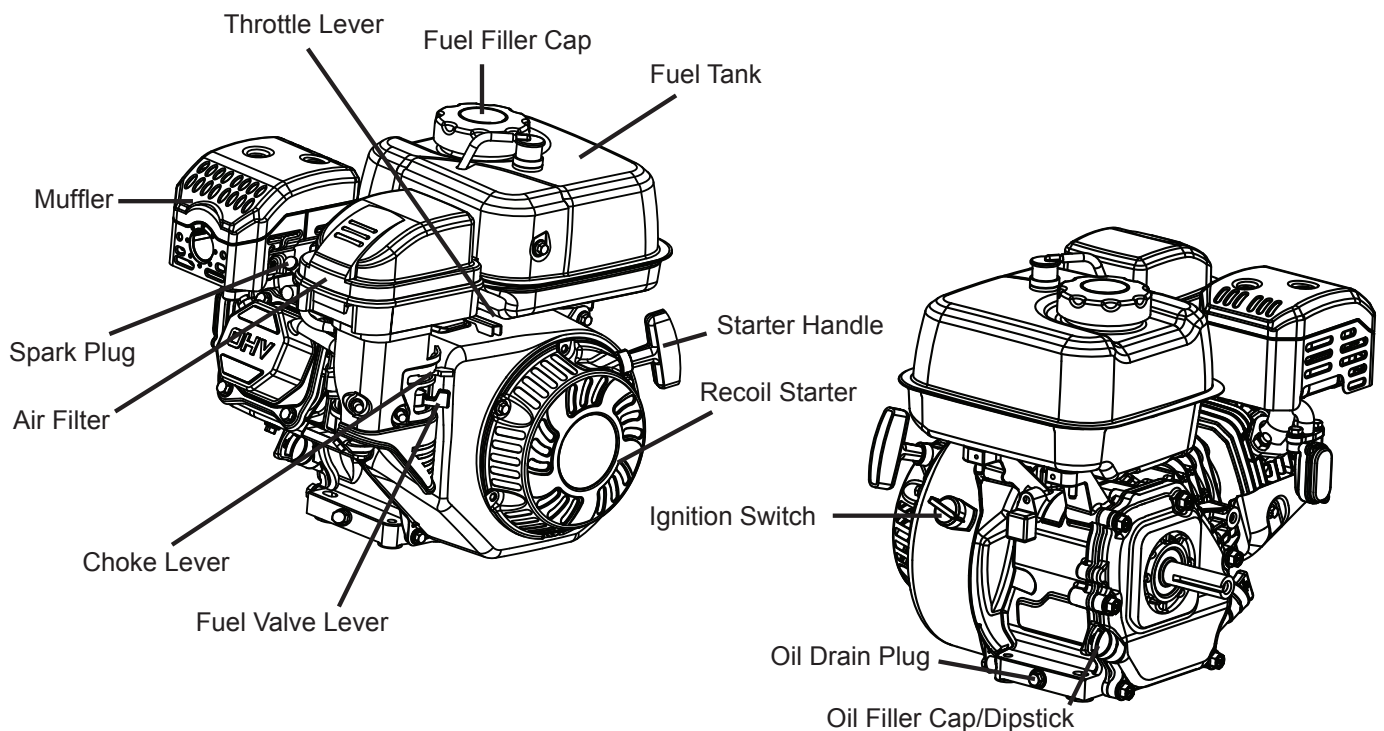

REV 11c

Operating Instructions



Read the **ENTIRE IMPORTANT SAFETY INFORMATION** section at the beginning of this manual including all text under subheadings therein before set up or use of this product.

Starting the Engine



Inspect engine and equipment looking for damaged, loose, and missing parts before set up and starting. If any problems are found, do not use equipment until fixed properly.

Checking Engine Oil Level

CAUTION Your Warranty is VOID if the engine's crankcase is not properly filled with oil before each use. Before each use, check the oil level. Do not run the engine with low or no engine oil. Running the engine with no or low engine oil WILL permanently damage the engine.

1. Make sure engine is level, then turn off engine, close the fuel valve, and allow engine to cool.
2. Clean the Oil Filler Cap and the area around it. Remove the Oil Filler Cap.

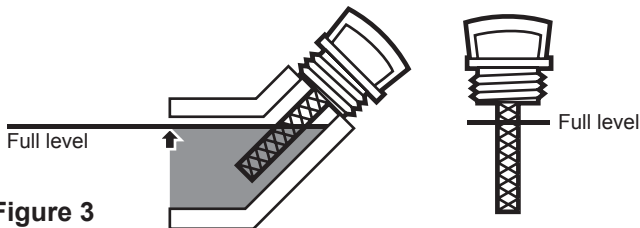

Figure 3

3. Remove dipstick and wipe away the oil with dry cloth. Reinsert the dipstick into the oil filler neck, but do not screw in, then remove it to check the oil level. The oil level should be up to the full level as shown above. Low oil level can trigger the low oil sensor to shutdown the engine and prevent restart.
4. If the oil level is low, add the appropriate type of oil until the oil level is at the bottom lip of the oil fill hole.

Oil type:

32° F or above = SAE 10W-30
Below 32° F = SAE 5W-30.

5. Replace the Oil Filler Cap.

CAUTION Do not run the engine with too little or too much oil. The engine will be permanently damaged.

Checking Pump Oil Level

1. The Oil pump is filled with 3.75 fl-oz of SAE 10W-30 NON DETERGENT oil at the factory. Under normal conditions there is no reason to add any oil or change the oil.
2. Turn off engine, allow it to cool and disconnect the spark plug wire.
3. Twist the Dipstick on the Pump Breather Plug until the arrow on it lines up with the arrow on the Plug and remove the Dipstick.
4. Remove the Pump Breather Plug from the Pump.

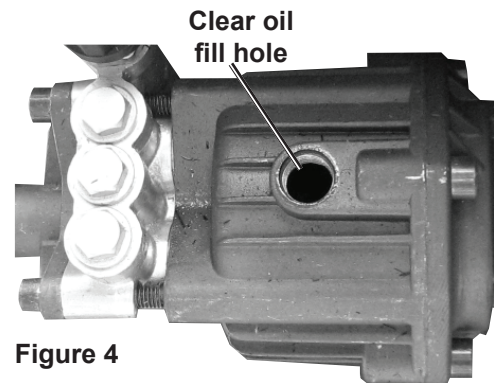

Figure 4

5. Look into the hole in the pump housing. If a metal wheel can be seen extending into the hole, SLOWLY pull the starter rope until the hole appears clear, as shown above.

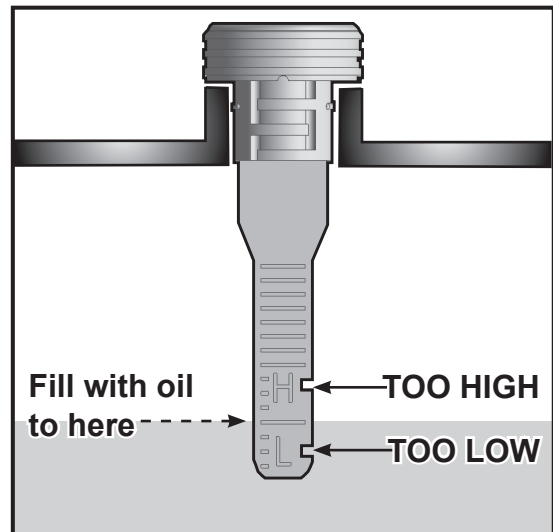

Figure 5

6. Wipe the Dipstick off with a clean, dry cloth. Insert the Dipstick into the pump housing and remove it. The oil level should be at least to the lower (L) notch on the dipstick, but not above the upper (H) notch. Add SAE 10W-30 NON-DETERGENT oil as needed.
7. Thread the Pump Breather Plug back into the pump.
8. Align the arrow on the Dipstick with the arrow on the Plug, insert it, and twist it to secure.
9. Reconnect the spark plug wire.

Checking and Filling Fuel



⚠️ WARNING! TO PREVENT SERIOUS INJURY FROM FIRE:

Fill the fuel tank in a well-ventilated area away from ignition sources. If the engine is hot from use, shut it off and wait for it to cool before adding fuel. Do not smoke.

1. Clean the Fuel Cap and the area around it.
2. Unscrew and remove the Fuel Cap.
3. Fill the fuel tank with 87 octane or higher unleaded gasoline to the top of the Fuel Level marker on the fuel strainer.

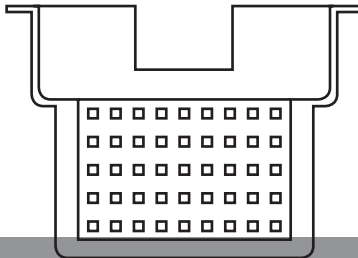

**Max Fuel
DO NOT OVERFILL!**

⚠️ WARNING! TO PREVENT FUEL LEAKAGE AND FIRE HAZARD, DO NOT OVERFILL.

Note: Do not use gasoline containing more than 10% ethanol (E10). Do not use E85 ethanol.

Note: Do not use gasoline that has been stored in a metal fuel container or a dirty fuel container. It can cause particles to enter the carburetor, affecting engine performance and/or causing damage.

4. Then replace the Fuel Cap.
5. Wipe up any spilled fuel and allow excess to evaporate before starting engine. To prevent FIRE, do not start the engine while the smell of fuel hangs in the air.

Start Procedure



Before starting the engine:

- a. Follow the Set Up Instructions to prepare the equipment, including installing the Breather, connecting then turning on the hose, and attaching the Nozzle.
- b. Fill the engine with the proper amount and type of both fuel and oil.
- c. Read the Equipment Operation section that follows.

1. Point Nozzle in safe direction and squeeze trigger to release all pressure from the pump.

2. To start the engine:

- a. To start a cold engine, move the Choke to the CHOKE position. To restart a warm engine, leave the Choke in the RUN position.

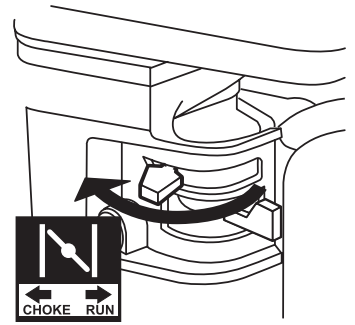

- b. Open the Fuel Valve.

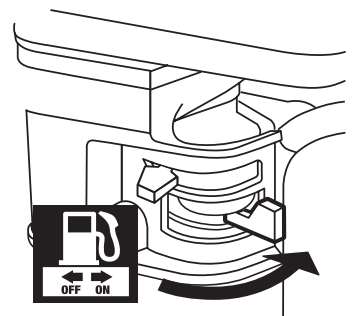

- c. Slide the Throttle or Speed Control Lever to 1/3 away from the SLOW position (the "turtle").

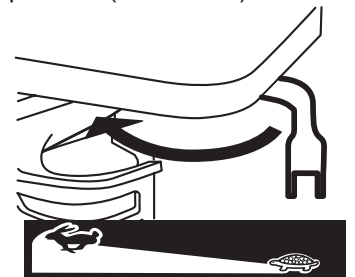

- d. Turn the Engine Switch on.

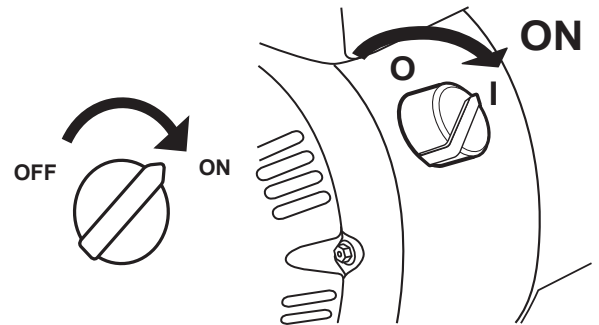

- e. Grip the Starter Handle of the Engine loosely and pull it slowly several times to allow the gasoline to flow into the Engine's carburetor. Then pull the Starter Handle gently until resistance is felt. Allow Cable to retract fully and then pull it quickly. Repeat until the engine starts.

Note: Do not let the Starter Handle snap back against the engine. Hold it as it recoils so it doesn't hit the engine.

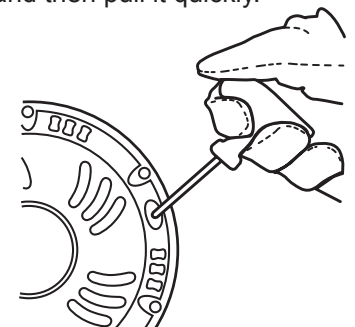

- f. Allow the Engine to run for several seconds. Then, if the Choke lever is in the CHOKE position, move the Choke Lever very slowly to its RUN position.

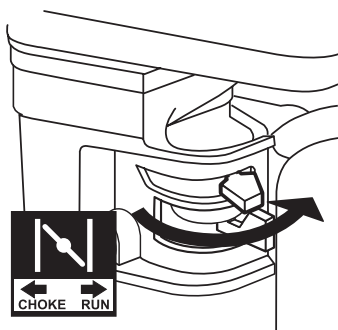

Note: Moving the Choke Lever too fast could stall the engine.

IMPORTANT: Allow the engine to run at no load for five minutes with no load after each start-up so that the engine can stabilize.

3. Move the throttle up to operating speed. Operating speed is maximum speed (fast or rabbit), except during operational break-in period.

Break-in Period

1. Breaking-in the engine will help to ensure proper equipment and engine operation.
2. The operational break-in period will last about 3 hours of use. During this period:
 - Do not apply a heavy load to the equipment.
 - Do not operate the engine at its maximum speed.

3. The maintenance break-in period will last about 20 hours of use. After this period:
 - Change the engine oil.
 Under normal operating conditions subsequent maintenance follows the schedule in the MAINTENANCE AND SERVICING section.

Equipment Operation

⚠ WARNING

Do not direct spray from the pressure washer at a person or an animal. The water stream could cause serious injury.

CAUTION

Use the pressure washer only on surfaces able to withstand the force of the spray.

1. Replace the non-vented brass oil plug with the aluminum Pump Breather Plug before first use. The Pump Breather Plug must be used whenever the pressure washer is used. The brass oil plug (without the breather hole) should be used for transporting only.
2. Choose the Nozzle that best meets the needs of the job. Only use the Nozzles on surfaces capable of withstanding the force of the spray. **Only use the Black Nozzle when using pressure washer detergent. The power of the other Nozzles will propel mist back at the operator and can embed detergent into the surface.**

3. Pull back the quick connect collar and push the Nozzle onto the end of the Wand. Make sure the quick connect collar locks the Nozzle in place.
 4. Turn the water supply on and hold down the Trigger to start the stream. Be aware that when it is first started, the gun will kick.
 5. It is best to start at a low pressure setting, and adjust the pressure upwards. Test spray the edge of the surface to be cleaned first to make sure that the stream is not too strong for the surface. If the stream damages the surface, turn the Pressure Regulator Knob counterclockwise to reduce the pressure. Moving further away from the surface being cleaned will also reduce the pressure being applied to the surface. If the stream is still too strong, turn the engine off, turn the water supply off, discharge the excess pressure from the gun by squeezing the Trigger, and change to a lower pressure Nozzle.
 6. To increase the pressure, turn the Pressure Regulator Knob clockwise.
 7. Hold the Wand at about a 45° angle when cleaning; spraying the surface directly could embed dirt into the surface (especially with the high pressure Nozzles). Spray at a distance of about three to five feet.
 - Clean vertical and sloped surfaces from the top down.
 - When cleaning horizontal surfaces, occasionally use the stream to clear the area of excess water.
- CAUTION Do not allow the Pressure Washer to idle without the Trigger held down, for more than two minutes. The water will heat up and damage the Pressure Washer. RISK OF BURNS! The pump will also expel very hot water if allowed to idle too long.**
8. Hold the Trigger down and move the Wand back and forth slowly and steadily to pressure wash the surface. Take special care when spraying surfaces made of two different materials (brick and mortar, for example), so as to not damage the softer of the two materials during pressure washing.
 9. If the surface is streaked or uneven at the end of a job, switch to a Nozzle that has a wider spray pattern to blend the affected area.
 10. When finished; release the Trigger on the spray handle, turn the engine power switch to "OFF", turn the water supply off and then shut off gas supply to the engine.
 11. Squeeze the Trigger to release excess pressure.
 12. If Pressure Washer detergent has been used for the job, run clean water through the system to eliminate detergent residue.
 13. To prevent accidents, turn off the engine and after the engine has cooled, disconnect its spark plug wire after use. Drain all water out of the unit. Clean external parts with clean cloth, then store the equipment out of children's reach.

Stopping the Engine

To stop the engine in an emergency, turn the engine switch off.

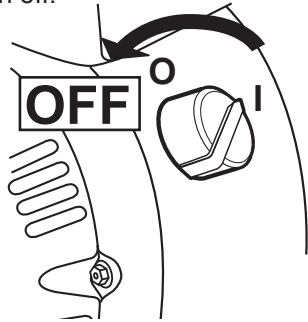

Under normal conditions, use the following procedure:

1. Slide the Throttle Lever to SLOW (the "turtle").



2. Turn the Engine Switch off.

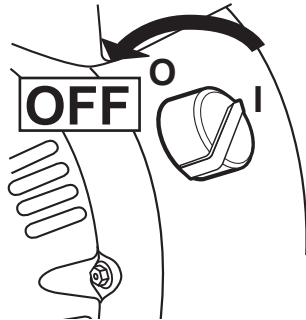

3. Close the Fuel Valve.

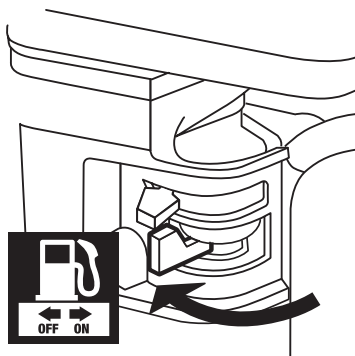

⚠️ WARNING

TO PREVENT SERIOUS INJURY FROM ACCIDENTAL STARTING:

Turn the Power Switch of the equipment to its “OFF” position, wait for the engine to cool, and disconnect the spark plug cap before performing any inspection, maintenance, or cleaning procedures.

TO PREVENT SERIOUS INJURY FROM EQUIPMENT FAILURE:

Do not use damaged equipment. If abnormal noise, vibration, or excess smoking occurs, have the problem corrected before further use.

Follow all service instructions in this manual. The engine may fail critically if not serviced properly.

Maintenance Procedures



Many maintenance procedures, including any not detailed in this manual, will need to be performed by a qualified technician for safety. If you have any doubts about your ability to safely service the equipment or engine, have a qualified technician service the equipment instead.

Cleaning, Maintenance, and Lubrication Schedule

Note: This maintenance schedule is intended solely as a general guide. If performance decreases or if equipment operates unusually, check systems immediately. The maintenance needs of each piece of equipment will differ depending on factors such as duty cycle, temperature, air quality, fuel quality, and other factors.

Note: The following procedures are in addition to the regular checks and maintenance explained as part of the regular operation of the engine and equipment.

Procedure	Before Each Use	Monthly or every 20 hr. of use	Every 3 mo. or 50 hr. of use	Every 6 mo. or 100 hr. of use	Yearly or every 300 hr. of use	Every 2 Years
Brush off outside of engine	✓	✓	✓	✓	✓	✓
Check engine oil level	✓	✓	✓	✓	✓	✓
Check air cleaner	✓		✓	✓	✓	✓
Check deposit cup	✓			✓	✓	✓
Change engine oil		✓		✓	✓	✓
Clean/replace air cleaner			✓*	✓	✓	✓
Check and clean spark plug				✓	✓	✓
1. Check/adjust idle speed 2. Check/adjust valve clearance 3. Clean fuel tank, strainer and carburetor 4. Clean carbon build-up from combustion chamber					✓**	✓**
Replace fuel line if necessary						✓**

* Service more frequently when used in dusty areas.

** These items should be serviced by a qualified technician.

Checking and Filling Fuel



⚠️ WARNING! TO PREVENT SERIOUS INJURY FROM FIRE:

Fill the fuel tank in a well-ventilated area away from ignition sources. If the engine is hot from use, shut it off and wait for it to cool before adding fuel. Do not smoke.

1. Clean the Fuel Cap and the area around it.
2. Unscrew and remove the Fuel Cap.
3. Fill the fuel tank with 87 octane or higher unleaded gasoline to the top of the Fuel Level marker on the fuel strainer.

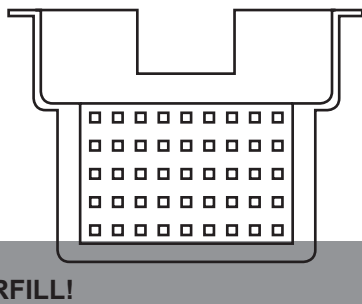

⚠️ WARNING! TO PREVENT FUEL LEAKAGE AND FIRE HAZARD, DO NOT OVERFILL.

Note: Do not use gasoline containing more than 10% ethanol (E10). Do not use E85 ethanol.

Note: Do not use gasoline that has been stored in a metal fuel container or a dirty fuel container. It can cause particles to enter the carburetor, affecting engine performance and/or causing damage.

4. Then replace the Fuel Cap.
5. Wipe up any spilled fuel and allow excess to evaporate before starting engine. To prevent FIRE, do not start the engine while the smell of fuel hangs in the air.

Engine Oil Change

⚠️ CAUTION Oil is very hot during operation and can cause burns. Wait for engine to cool before changing oil.

1. Make sure the engine is stopped and is level.
2. Close the Fuel Valve.
3. Place a drain pan (not included) underneath the crankcase's drain plug.
4. Remove the drain plug and, if possible, tilt the crankcase slightly to help drain the oil out. Recycle used oil.
5. Replace the drain plug and tighten it.

6. Clean the top of the Dipstick and the area around it. Remove the Dipstick by threading it counterclockwise, and wipe it off with a clean lint free rag.

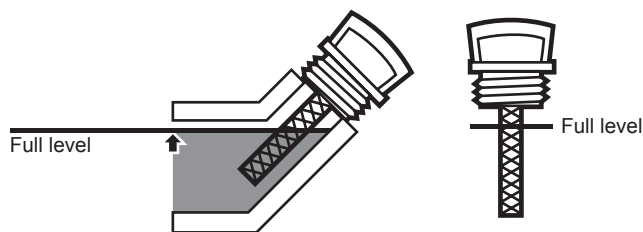

7. Add the appropriate type of oil until the oil level is at the full level. SAE 10W-30 oil is recommended for general use. The SAE Viscosity Grade chart shows other viscosities to use in different average temperatures.

SAE Viscosity Grades

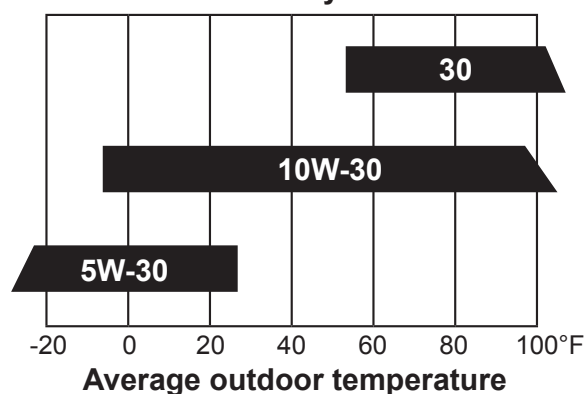

8. Thread the dipstick back in clockwise.

CAUTION Do not run the engine with too little oil. The engine will be permanently damaged.

Air Filter Element Maintenance

1. Remove the air filter cover and the air filter elements and check for dirt. Clean or replace as described below.
2. **Cleaning:**
 - For "paper" filter elements:
To prevent injury from dust and debris, wear ANSI-approved safety goggles, NIOSH-approved dust mask/respirator, and heavy-duty work gloves. In a well-ventilated area away from bystanders, use pressurized air to blow dust out of the air filter. If this does not get the filter clean, replace it.
 - For foam filter elements:
Wash the element in warm water and mild detergent several times. Rinse. Squeeze out excess water and allow it to dry completely. Soak the filter in lightweight oil briefly, then squeeze out the excess oil.
3. Install the new filter or the cleaned filter. Secure the Air Cleaner Cover before use.

Spark Plug Maintenance

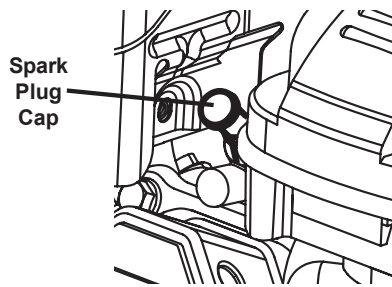

1. Disconnect spark plug cap from end of plug. Clean out debris from around spark plug.
2. Using a spark plug wrench, remove the spark plug.
3. Inspect the spark plug:
If the electrode is oily, clean it using a clean, dry rag. If the electrode has deposits on it, polish it using emery paper. If the white insulator is cracked or chipped, the spark plug needs to be replaced.

Recommended Spark Plugs	
Brand	Item Number
NGK®	BP-6ES
NHSP® / TORCH®	F6TC

NOTICE: Using an incorrect spark plug may damage the engine.

4. When installing a new spark plug, adjust the plug's gap to the specification on the Technical Specifications chart. Do not pry against the electrode, the spark plug can be damaged.
5. Install the new spark plug or the cleaned spark plug into the engine.
Gasket-style: Finger-tighten until the gasket contacts the cylinder head, then about 1/2-2/3 turn more.
Non-gasket-style: Finger-tighten until the plug contacts the head, then about 1/16 turn more.

NOTICE: Tighten the spark plug properly. If loose, the spark plug will cause the engine to overheat. If overtightened, the threads in the engine block will be damaged.

6. Apply dielectric spark plug boot protector (not included) to the end of the spark plug and reattach the wire securely.

Storage

When the equipment is to remain idle for longer than 20 days, prepare the engine for storage as follows:

1. **CLEANING:**
Wait for engine to cool, then clean with dry cloth.

NOTICE: Do not clean engine using water. The water will gradually enter the engine and cause rust damage. Apply a thin coat of rust preventive oil to all metal parts.

2. FUEL:



⚠ WARNING! TO PREVENT SERIOUS INJURY FROM FIRE:

Drain the fuel tank in a well-ventilated area away from ignition sources. If the engine is hot from use, shut it off and wait for it to cool before draining fuel. Do not smoke.

- a. Place a funnel leading to a proper gasoline container below the carburetor.

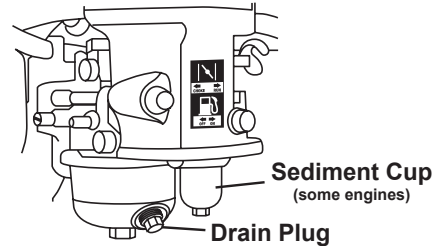

- b. Remove the drain bolt from the bottom of the carburetor bowl and allow the fuel to drain.
- c. Remove the small sediment cup next to the bowl and allow the fuel to drain from there as well.
- d. Open the fuel valve. After all fuel has drained, reinstall the drain bolt and sediment cup (if equipped). Tighten securely.

3. LUBRICATION:

- a. Change engine oil.
- b. Clean out area around spark plug. Remove spark plug and pour one tablespoon of engine oil into cylinder through spark plug hole.
- c. Replace spark plug, but leave spark plug cap disconnected.
- d. Pull Starter Handle to distribute oil in cylinder. Stop after one or two revolutions when you feel the piston start the compression stroke (when you start to feel resistance).

4. BATTERY:

Disconnect battery cables (if equipped). Recharge batteries monthly while in storage.

5. STORAGE AREA:

Cover and store in a dry, level, well-ventilated area out of reach of children. Storage area should also be away from ignition sources, such as water heaters, clothes dryers, and furnaces.

6. AFTER STORAGE:

Before starting the engine after storage, keep in mind that untreated gasoline will deteriorate quickly. Drain the fuel tank and change to fresh fuel if untreated gasoline has been sitting for a month, if treated gasoline has been sitting beyond the fuel stabilizer's recommended time period, or if the engine does not start.

Troubleshooting

Problem	Possible Causes	Probable Solutions
Engine will not start	Starting instructions not followed completely.	Refer to starting instructions and follow them step-by-step.
	FUEL RELATED: <ol style="list-style-type: none"> 1. No fuel in tank or fuel valve closed. 2. Choke not in start position, especially with cold engine. 3. Low quality or deteriorated, old gasoline. 4. Dirty fuel passageways blocking fuel flow. 5. Carburetor needle stuck. Fuel can be smelled in the air. 6. Too much fuel in chamber. This can be caused by the carburetor needle sticking. 	FUEL RELATED: <ol style="list-style-type: none"> 1. Fill fuel tank and open fuel valve. 2. Move choke to start position if engine is cold. 3. Use only fresh 87+ octane unleaded gasoline. 4. Clean out passageways using fuel additive. Heavy deposits may require further cleaning. 5. Gently tap side of carburetor float chamber with screwdriver handle. 6. Turn choke to run position. Remove spark plug and pull the start handle several times to air out the chamber. Reinstall spark plug and set choke to start position.
	IGNITION (SPARK) RELATED: <ol style="list-style-type: none"> 1. Spark plug wire not connected securely. 2. Spark plug electrode wet or dirty. 3. Incorrect spark plug gap. 4. Spark plug wire broken. 5. Incorrect spark timing or faulty ignition system. 	IGNITION (SPARK) RELATED: <ol style="list-style-type: none"> 1. Connect spark plug wire properly. 2. Clean spark plug. 3. Correct the spark plug gap. 4. Replace spark plug wire. 5. Have qualified technician diagnose/repair ignition system.
COMPRESSION RELATED: <ol style="list-style-type: none"> 1. Cylinder not lubricated. Problem after long storage periods. 2. Loose or broken spark plug. (Hissing noise will occur when trying to start.) 3. Loose cylinder head or damaged head gasket. (Hissing noise will occur when trying to start.) 4. Engine valves or tappets misadjusted or stuck. 	COMPRESSION RELATED: <ol style="list-style-type: none"> 1. Pour tablespoon of oil into spark plug hole. Crank engine a few times and try to start again. 2. Tighten spark plug. If that does not work, replace spark plug. If problem persists, may have head gasket problem, see #3. 3. Tighten head. If that does not remedy problem, replace head gasket. 4. Adjust valve clearance. If that does not work, clean or replace valves/tappets. 	
Engine misfires	<ol style="list-style-type: none"> 1. Spark plug wire loose. 2. Incorrect spark plug gap or damaged spark plug. 3. Defective spark plug wire. 4. Old or low quality gasoline. 5. Incorrect compression. 	<ol style="list-style-type: none"> 1. Check wire connections. 2. Re-gap or replace spark plug. 3. Replace spark plug wire. 4. Use only fresh 87+ octane unleaded gasoline. 5. Diagnose and repair compression. (Use Engine will not start: COMPRESSION RELATED section.)



Follow all safety precautions whenever diagnosing or servicing the equipment or engine.

Problem	Possible Causes	Probable Solutions
Engine stops suddenly	<ol style="list-style-type: none"> 1. Low oil shutdown. 2. Fuel tank empty or full of impure or low quality gasoline. 3. Defective fuel tank cap creating vacuum, preventing proper fuel flow. 4. Faulty magneto. 	<ol style="list-style-type: none"> 1. Fill engine oil to proper level. Check engine oil before EVERY use. 2. Fill fuel tank with fresh 87+ octane unleaded gasoline. 3. Test/replace fuel tank cap. 4. Have qualified technician service magneto.
Engine knocks	<ol style="list-style-type: none"> 1. Old or low quality gasoline. 2. Engine overloaded. 3. Incorrect spark timing, deposit buildup, worn engine, or other mechanical problems. 	<ol style="list-style-type: none"> 1. Fill fuel tank with fresh 87+ octane unleaded gasoline. 2. Do not exceed equipment's load rating. 3. Have qualified technician diagnose and service engine.
Engine backfires	<ol style="list-style-type: none"> 1. Impure or low quality gasoline. 2. Engine too cold. 3. Intake valve stuck or overheated engine. 	<ol style="list-style-type: none"> 1. Fill fuel tank with fresh 87+ octane unleaded gasoline. 2. Use cold weather fuel and oil additives to prevent backfiring. 3. Have qualified technician diagnose and service engine.
Does not produce high pressure	<ol style="list-style-type: none"> 1. Diameter of water supply hose too small 2. Water supply is restricted. 3. Not enough water supply. 	<ol style="list-style-type: none"> 1. Replace hose with a 3/4 inch hose. 2. Check water supply hose for kinks, leaks, or blockage. 3. Open water faucet all the way.
Output pressure varies	<ol style="list-style-type: none"> 1. Not enough water supply. 2. Water inlet screen is clogged. 3. Nozzle is clogged. 4. Nozzle has mineral build up. 	<ol style="list-style-type: none"> 1. Check water supply hose for kinks, leaks, or blockage. Open faucet all the way. 2. Remove inlet screen and rinse out. 3. Remove Nozzle and clean. 4. Remove Nozzle and clean with vinegar.
No intake of chemicals.	<ol style="list-style-type: none"> 1. Chemical hose not properly inserted into unit. 2. Tube cracked or split. 3. Wrong Nozzle. 4. Injector turned off. 5. Injection tube strainer clogged. 6. Nozzle blocked. 7. Dried chemicals in injector. 	<ol style="list-style-type: none"> 1. Push firmly into injector. Replace tube. 2. Switch to black Nozzle. 3. Turn collar counterclockwise. 4. Clean strainer. 5. Clean Nozzle. 6. Dissolve by running warm water through the injection tube. 7. Run clean water through injector until clear.



Follow all safety precautions whenever diagnosing or servicing the equipment or engine.

General Parts List

Part	Description	Qty
1	Gun & Hose Holder	1
2	Washer	1
3	Nut	1
4	Grommet	5
5	Nozzle	5
6	Label	1
7	Filter	1
8	Detergent Inlet Hose	1
9	Bolt	4
10	Lock Washer	4
11	Pump Assembly	1
12	Engine Item 67546 (EPA version) Item 67596 (EPA/CARB version)	1
13	Key	1
14	Handle	1
15	Handle Bolt	2
16	Swivel Nut	2
17	Frame	1
18	Hose	1
19	Gun	1

Part	Description	Qty
20	Wand	1
21	Pad	2
22	Washer	2
23	Nut	2
24	Engine Bolt	4
25	Lock Washer	2
26	Washer	2
27	Nut	2
28	Lock Washer	2
29	Axle Nut	2
30	Lock Washer	2
31	Washer	2
32	Axle	2
33	Clip	2
34	Wheel	2
35	Washer	2
36	Wheel Nut	2
37	Dipstick	1
38	Breather Plug	1
39	O-ring	1
40	Shock Pad	4

Record Product's Serial Number Here: _____

Note: If product has no serial number, record month and year of purchase instead.

Note: Some parts are listed and shown for illustration purposes only, and are not available individually as replacement parts.

PLEASE READ THE FOLLOWING CAREFULLY

THE MANUFACTURER AND/OR DISTRIBUTOR HAS PROVIDED THE PARTS LIST AND ASSEMBLY DIAGRAM IN THIS MANUAL AS A REFERENCE TOOL ONLY. NEITHER THE MANUFACTURER OR DISTRIBUTOR MAKES ANY REPRESENTATION OR WARRANTY OF ANY KIND TO THE BUYER THAT HE OR SHE IS QUALIFIED TO MAKE ANY REPAIRS TO THE PRODUCT, OR THAT HE OR SHE IS QUALIFIED TO REPLACE ANY PARTS OF THE PRODUCT. IN FACT, THE MANUFACTURER AND/OR DISTRIBUTOR EXPRESSLY STATES THAT ALL REPAIRS AND PARTS REPLACEMENTS SHOULD BE UNDERTAKEN BY CERTIFIED AND LICENSED TECHNICIANS, AND NOT BY THE BUYER. THE BUYER ASSUMES ALL RISK AND LIABILITY ARISING OUT OF HIS OR HER REPAIRS TO THE ORIGINAL PRODUCT OR REPLACEMENT PARTS THERETO, OR ARISING OUT OF HIS OR HER INSTALLATION OF REPLACEMENT PARTS THERETO.

REV 11c

General Assembly Diagram

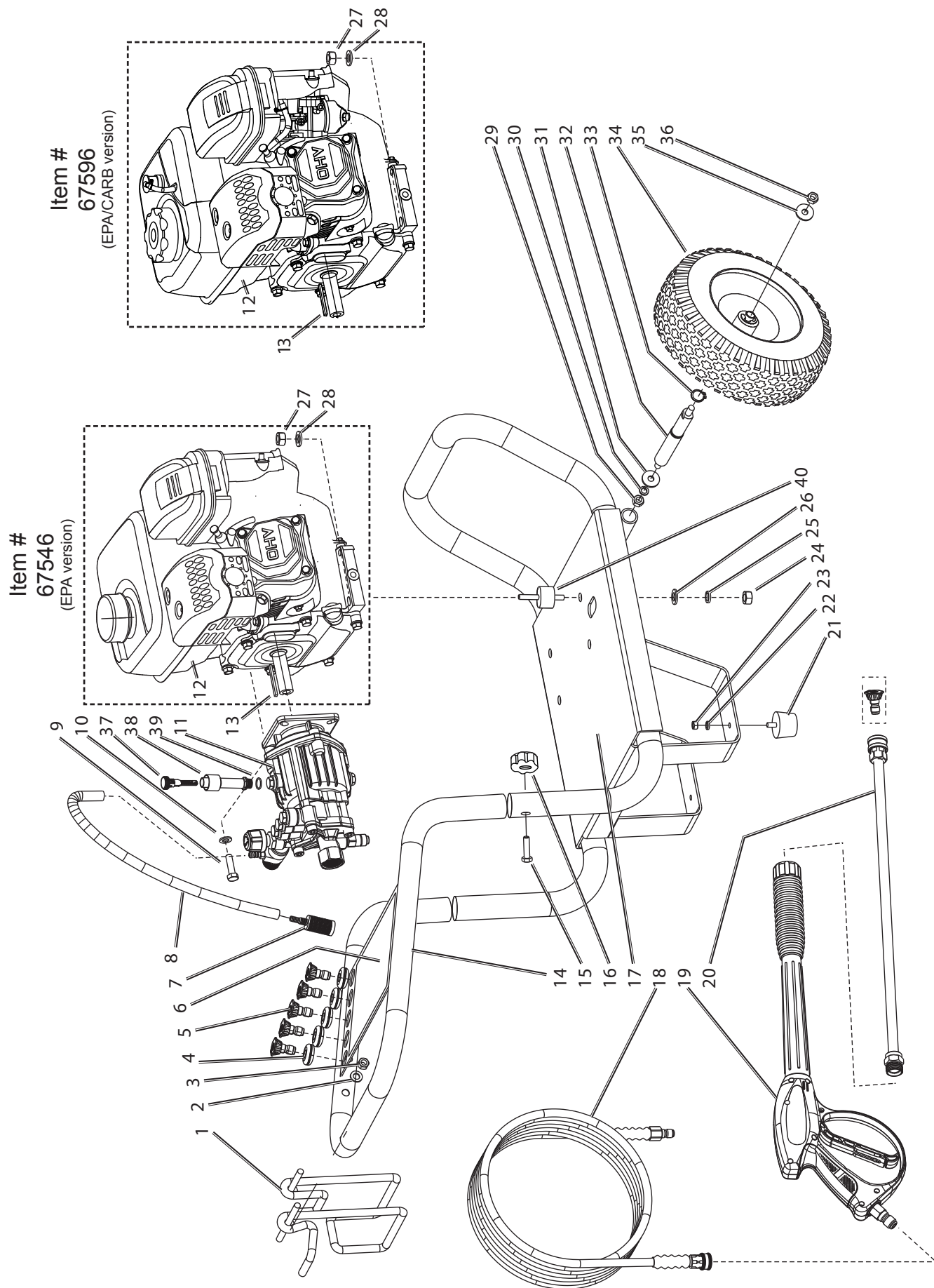

Parts List A - Pump

Part	Description
1A	Screw M8x16
2A	Flange
3A	O-Ring 80x2,4
4A	Radial Shaft Seal
5A	Real Bearing
6A	Sheath
7A	Wobble Plate
8A	Front Bearing
9A	Spring Disk
10A	15mm Plunger
11A	Plunger Spring
12A	Crankcase
13A	O-Ring 14.2x1.9
14A	Pump Breather Plug
15A	Dipstick
16A	Oil Seal
17A	O-ring 15x2.2
18A	Spacer
19A	O-Ring 22x2
20A	Pressure Ring

Part	Description
21A	Water Seal
22A	Inlet Valve Plug
23A	Backup Ring
24A	O-Ring
25A	Check Valve
26A	Detergent Inlet
27A	O-Ring 4.47x1.78
28A	Ball
29A	Cone Spring
30A	O-Ring
31A	Outlet Valve
32A	Valve Spring
33A	O-Ring
34A	Siphon Body
35A	Outlet Connector
36A	Backup Ring
37A	O-Ring
38A	Valve Core
39A	Plug
40A	Pump Manifold

Part	Description
41A	Seal Gasket
42A	Water Inlet Body
43A	Thermal Relief Valve
44A	Inlet Swivel Nut
45A	Clip Ring
46A	Water Filter
47A	Manifold Bolt
48A	Pressure Regulator Knob
49A	Screw Plug
50A	O-Ring
51A	Backup Ring
53A	O-Ring
52A	Spring Holder
54A	Large Pressure Spring
55A	Small Pressure Spring
56A	Ball Holder
57A	Ball
58A	Valve Port
59A	O-Ring
60A	Shipping Oil Plug

When ordering replacement parts from this list, the "A" suffix must be included in order to get the correct part.

Assembly Diagram A - Pump

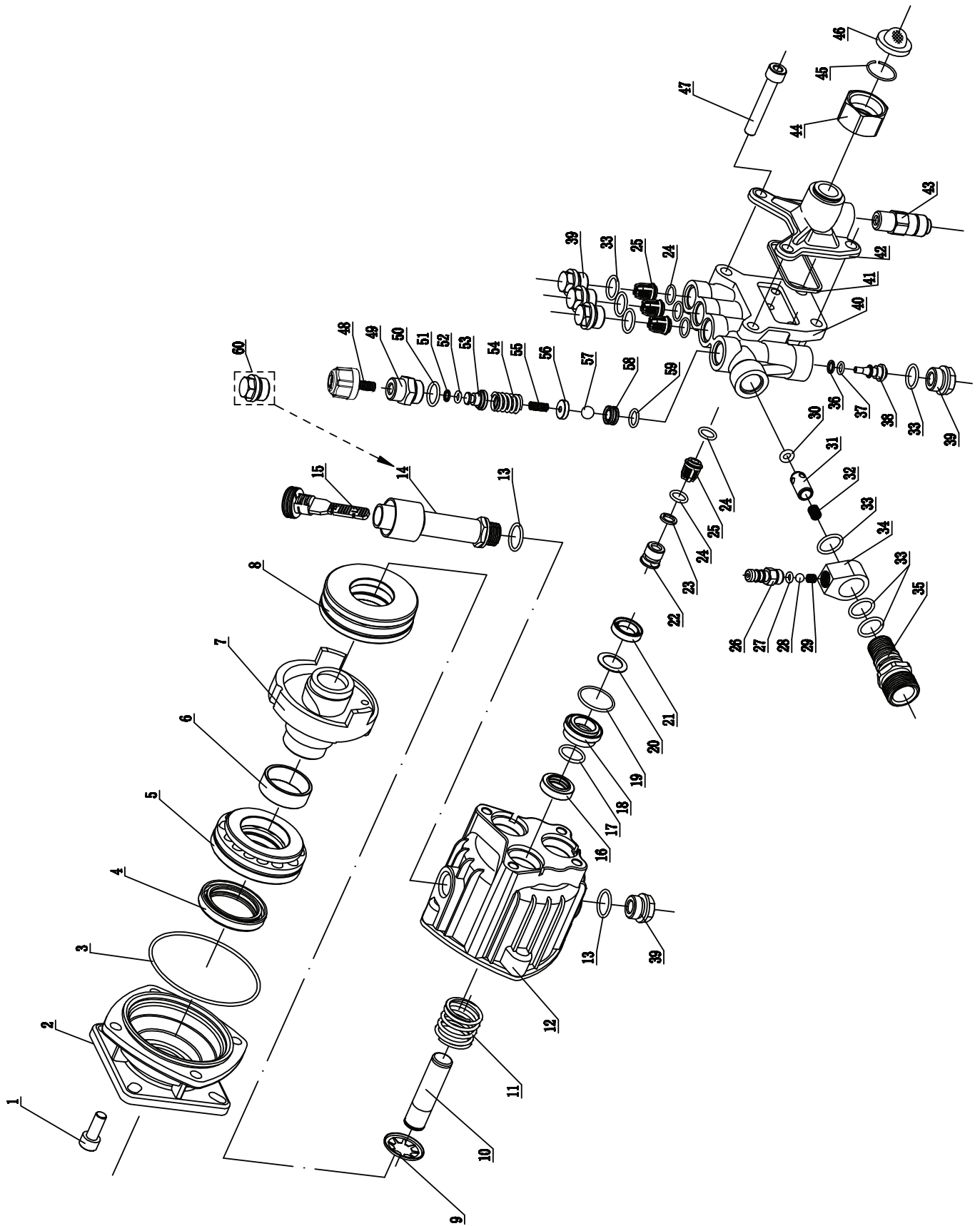

Parts List B - Engine - Item # 67546 (EPA version)

Part	Description	Qty
1B	Gasket, Cylinder Head	1
2B	Cover Asm., Cylinder Head	1
3B	Gasket, Cylinder Head Cover	1
4B	Tube, Breather	1
5B	Bolt	4
6B	Stud	1
7B	Stud	1
8B	Stud	2
9B	Pin	2
10B	Bolt, Cylinder Head	4
11B	Plug, Spark	1
12B	Head Asm., Cylinder	1
13B	Crankcase Asm.	1
14B	Sensor, Engine Oil	1
15B	Gear Asm., Governor	1
16B	Arm, Governor	1
17B	Bolt, Drain Plug	2
18B	Washer	2
19B	Bearing	1
20B	Seal, Oil	1
21B	Washer	1
22B	Pin	1
23B	Bolt	2
24B	Cover, Crankcase	1
25B	Bearing	1
26B	Seal, Oil	1
27B	Gasket, Crankcase	1
28B	Pin	2
29B	Dipstick Asm., Oil	1
30B	Plug Asm., Engine Oil	1
31B	Bolt	6
32B	Crankshaft Asm.	1
33B	Clip, Piston Pin	2
34B	Piston	1
35B	Pin, Piston	1
36B	Rod, Connecting	1
37B	Ring, Primary	1
38B	Ring, Secondary	1
39B	Ring Set, Oil	1
40B	Camshaft Asm.	1
41B	Valve, Exhaust	1
42B	Valve, Intake	1
43B	Seat, Valve Spring	1
44B	Retainer, Exhaust Valve	1
45B	Rotator, Valve	1
46B	Guide, Seal	1
47B	Tappet, Valve	2
48B	Lifter, Valve	2
49B	Plate Asm., Lifter Stopper	1
50B	Bolt, Valve Adjusting	2

Part	Description	Qty
51B	Rocker, Valve	2
52B	Nut, Valve Adjusting	2
53B	Nut, Valve Lock	2
54B	Spring, Valve	2
55B	Starter Asm., Recoil	1
56B	Bolt	3
57B	Shroud	1
58B	Shroud, Cylinder Body	1
59B	Shield, Lower	1
60B	Protector, Oil	1
61B	Switch Asm., Stop Engine	1
62B	Bolt	2
63B	Bolt	1
64B	Collar	1
65B	Bolt	1
66B	Bolt	4
67B	Carburetor Asm.	1
68B	Gasket, Air Cleaner	1
69B	Gasket, Carburetor	1
70B	Plate, Carburetor Insulator	1
71B	Gasket, Carburetor Insulator	1
72B	Nut	2
73B	Air Filter	1
74B	Bolt	1
75B	Gasket, Exhaust Outlet	1
76B	Nut	2
77B	Muffler Asm.	1
78B	Tank, Fuel	1
79B	Strainer, Fuel	1
80B	Cover, Fuel Tank	1
81B	Outlet Asm., Fuel Tank Oil	1
82B	Collar	2
83B	Tube, Fuel	1
84B	Bolt	1
85B	Nut	2
86B	Nut, Flywheel	1
87B	Pulley, Starter	1
88B	Impeller	1
89B	Flywheel Asm.	1
90B	Bolt	2
91B	Coil, Ignition	1
92B	Control Asm., Throttle	1
93B	Bolt	2
94B	Spring, Governor	1
95B	Rod, Governor	1
96B	Spring, Throttle Valve Returning	1
97B	Bolt, Governor Support	1
98B	Nut	1
99B	Support Asm., Governor	1

When ordering replacement parts from this list, the "B" suffix must be included in order to get the correct part.

Parts List B - Engine - Item # 67596 (EPA/CARB version)

Part	Description	Qty
1B	Gasket, Cylinder Head	1
2B	Cover Subassembly, Cylinder Head	1
3B	Gasket, Cylinder Head Cover	1
4B	Tube, Breather	1
5B	Bolt	4
6B	Stud	1
7B	Stud	1
8B	Stud	2
9B	Pin	2
10B	Bolt, Cylinder Head	4
11B	Plug, Spark	1
12B	Head Subassembly, Cylinder	1
13B	Crankcase Subassembly	1
14B	Sensor, Engine Oil	1
15B	Gear Assy, Governor	1
16B	Arm, Governor	1
17B	Bolt, Drain Plug	2
18B	Washer	2
19B	Bearing	1
20B	Seal, Oil	1
21B	Washer	1
22B	Pin	1
23B	Bolt	2
24B	Cover, Crankcase	1
25B	Bearing	1
26B	Seal, Oil	1
27B	Gasket, Crankcase	1
28B	Pin	2
29B	Dipstick Subassembly, Oil	1
30B	Plug Subassembly, Engine Oil	1
31B	Bolt	6
32B	Crankshaft Assy.	1
33B	Clip, Piston Pin	2
34B	Piston	1
35B	Pin, Piston	1
36B	Rod, Connecting	1
37B	Ring, Primary	1
38B	Ring, Secondary	1
39B	Ring Set, Oil	1
40B	Camshaft Assy.	1
41B	Valve, Exhaust	1
42B	Valve, Intake	1
43B	Seat, Valve Spring	1
44B	Exhaust Valve Retainer	1
45B	ROtator, Valve	1
46B	Guide, Seal	1
47B	Tappet, Valve	2
48B	Lifter, Valve	2
49B	Plate Subassembly, Lifter Stopper	1
50B	Bolt, Valve Adjusting	2
51B	Rocker, Valve	2
52B	Valve Adjusting Nut	2
53B	Nut, Valve Lock	2
54B	Spring, Valve	2
55B	Starter Assy, Recoil	1
56B	Bolt	3

Part	Description	Qty
57B	Shroud	1
58B	Shroud, Cylinder Body	1
59B	Shield, Lower	1
60B	Protector, Oil	1
61B	Switch Subassembly, Stop Engine	1
62B	Bolt	2
63B	Bolt	1
64B	Collar	1
65B	Bolt	1
66B	Bolt	4
67B	Carburetor Assy.	1
68B	Gasket, Air Cleaner	1
69B	Gasket, Carburetor	1
70B	Plate, Carburetor Insulator	1
71B	Gasket, Carburetor Insulator	1
72B	Nut	2
73B	Air Filter	1
74B	Gasket, Exhaust Outlet	1
75B	Nut	2
76B	Muffler Assy.	1
77B	Bolt	2
78B	Gasket, Secondary Supply Air Valve Flange	1
79B	Valve, Muffler Secondary Supply Air	1
80B	Tank, Fuel	1
81B	Fuel Strainer	1
82B	Cover, Fuel Tank	1
83B	Outlet Subassembly, Fuel Tank Oil	1
84B	Collar	4
85B	Tube, Fuel	1
86B	Bolt	1
87B	Nut	2
88B	Valve, One Way	1
89B	Hose, Fuel Vapor Rubber	1
90B	Collector, Fuel Vapor	1
91B	Clamp	1
92B	Clamp	1
93B	Hose, Air Cleaner Rubber	1
94B	Cover, Fuel Vapor Collector	1
95B	Bolt	2
96B	Jacket, Rubber	1
97B	Nut, Flywheel	1
98B	Pulley, Starter	1
99B	Impeller	1
100B	Flywheel Subassembly	1
101B	Bolt	2
102B	Coil, Ignition	1
103B	Control Assy, Throttle	1
104B	Bolt	2
105B	Spring, Governor	1
106B	Rod, Governeor	1
107B	Spring, Throttle Valve Returning	1
108B	Bolt, Governor Support	1
109B	Nut	1
110B	Support Subassembly, Governor	1

When ordering replacement parts from this list, the "B" suffix must be included in order to get the correct part.

Assembly Diagram B - Engine - Item # 67596 (EPA/CARB version)

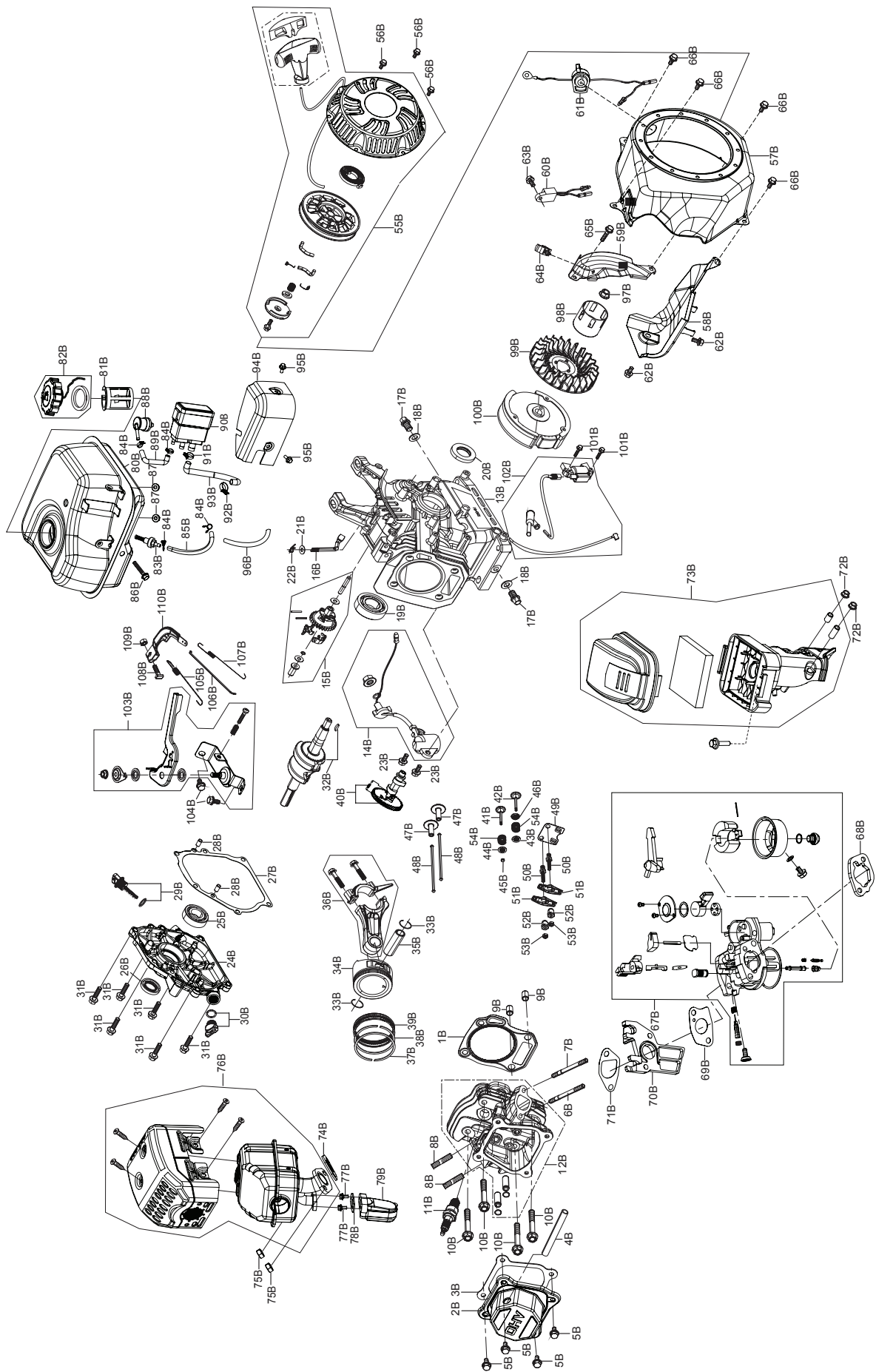

REV 11c

SKU 67546/67596

For Pressure Washer technical questions, please call 1-800-444-3353.
For Engine technical questions, please call 1-800-520-0882.

Page 25

Limited 90 Day Warranty

Harbor Freight Tools Co. makes every effort to assure that its products meet high quality and durability standards, and warrants to the original purchaser that this product is free from defects in materials and workmanship for the period of 90 days from the date of purchase. This warranty does not apply to damage due directly or indirectly, to misuse, abuse, negligence or accidents, repairs or alterations outside our facilities, criminal activity, improper installation, normal wear and tear, or to lack of maintenance. We shall in no event be liable for death, injuries to persons or property, or for incidental, contingent, special or consequential damages arising from the use of our product. Some states do not allow the exclusion or limitation of incidental or consequential damages, so the above limitation of exclusion may not apply to you. THIS WARRANTY IS EXPRESSLY IN LIEU OF ALL OTHER WARRANTIES, EXPRESS OR IMPLIED, INCLUDING THE WARRANTIES OF MERCHANTABILITY AND FITNESS.

To take advantage of this warranty, the product or part must be returned to us with transportation charges prepaid. Proof of purchase date and an explanation of the complaint must accompany the merchandise. If our inspection verifies the defect, we will either repair or replace the product at our election or we may elect to refund the purchase price if we cannot readily and quickly provide you with a replacement. We will return repaired products at our expense, but if we determine there is no defect, or that the defect resulted from causes not within the scope of our warranty, then you must bear the cost of returning the product.

This warranty gives you specific legal rights and you may also have other rights which vary from state to state.

3491 Mission Oaks Blvd. • PO Box 6009 • Camarillo, CA 93011

Emission Control System Warranty

United States Emission Control Defects Warranty Statement (for Item 67546)

The United States Environmental Protection Agency (herein EPA) and Harbor Freight Tools (herein HFT) are pleased to explain the emission control system warranty on your 1997 and later Small Off-Road Engine (herein engine). Within the United States, new off-road, spark-ignition engines certified for model year 1997 and later, must be designed, built and equipped to meet the stringent anti-smog standards set forth by the EPA. HFT must warrant the emission control system on your engine for the periods of time described below, provided there has been no abuse, neglect or improper maintenance of your engine.

Your emission control system may include parts such as the carburetor or fuel-injection system, and the ignition system. Also included may be hoses, belts, connectors and other emission-related assemblies.

Where a warrantable condition exists, HFT will repair your engine at no cost to you including diagnosis, parts and labor.

California and United States Emission Control Defects Warranty Statement (for Item 67596)

The California Air Resources Board (herein CARB), the United States Environmental Protection Agency (herein EPA), and Harbor Freight Tools (herein HFT) are pleased to explain the emission control system warranty on your 1995 and later Small Off-Road Engine (herein engine). In California, the engine must be designed, built and equipped to meet the State's stringent anti-smog standards. Elsewhere within the United States, new off-road, spark-ignition engines certified for model year 1997 and later, must meet similar standards set forth by the EPA. HFT must warrant the emission control system on your engine for the periods of time described below, provided there has been no abuse, neglect or improper maintenance of your engine.

Your emission control system may include parts such as the carburetor or fuel-injection system, and the ignition system. Also included may be hoses, belts, connectors and other emission-related assemblies.

Where a warrantable condition exists, HFT will repair your engine at no cost to you including diagnosis, parts and labor.

Manufacturer's Warranty Coverage

The 1995 and later engines are warranted for two (2) years. If any emission-related part on your engine is defective, the part will be repaired or replaced by HFT.

Harbor Freight Tools Emission Control Defects Warranty Coverage

Engines are warranted for a period of two (2) years relative to emission control parts defects, subject to the provisions set forth below. If any emission related part on your engine is defective, the part will be repaired or replaced by HFT.

Owner's Warranty Responsibilities

- As the engine owner, you are responsible for the performance of the required maintenance listed in your Owner's Manual. HFT recommends that you retain all receipts covering maintenance on your engine, but HFT cannot deny warranty solely for the lack of receipts or for your failure to ensure the performance of all scheduled maintenance.
- As the engine owner, you should, however, be aware that HFT may deny you warranty coverage if your engine or a part has failed due to abuse, neglect, improper maintenance, or unapproved modifications.
- You are responsible for shipping your engine to a HFT warranty station as soon as a problem exists. Contact the HFT Customer Service department at the number below to make shipping arrangements. The warranty repairs should be completed in a reasonable amount of time, not to exceed 30 days.

If you have any questions regarding your warranty rights and responsibilities, you should contact the Harbor Freight Tools Customer Service Department at 1-800-520-0882.

Harbor Freight Tools Emission Control Defects Warranty Provisions

1. Length of Coverage

HFT warrants to a first retail purchaser and each subsequent purchaser that the engine is free from defects in materials and workmanship that cause the failure of warranted parts for a period of two (2) years after the date of delivery to the first retail purchaser.

2. No Charge Repair or Replacement

Repair or replacement of any warranted part will be performed at no charge to the owner if the work is performed through a warranty station authorized by HFT. For emissions warranty service, contact the HFT Customer Service Department at 1-800-520-0882.

3. Consequential Damages Coverage

Coverage under this warranty shall also extend to the failure of any engine components caused by the failure of any warranted part while it is still covered under this warranty.

4. Coverage Exclusions

Warranty claims shall be filed in accordance with the provisions of the HFT warranty policy explained in the box at the top of the previous page. HFT shall not be liable for any loss of use of the engine, for any alternative usage, for any damage to goods, loss of time, or inconvenience. Warranty coverage shall also be excluded for any part which fails, malfunctions, or is damaged due to failure to follow the maintenance and operating instructions set forth in the Owner's Manual including, but not limited to:

- a) Use of parts which are not authorized by HFT
- b) Improper installation, adjustment or repair of the engine or of any warranted part unless performed by an authorized warranty center
- c) Failure to follow recommendations on fuel use contained in the Owner's Manual
- d) Improper or inadequate maintenance of any warranted parts
- e) Repairs performed outside of the authorized warranty service dealers
- f) Alterations by changing, adding to or removing parts from the engine.

5. Service and Maintenance

Component parts which are not scheduled for replacement as required maintenance or are scheduled only for regular inspection to the effect of "repair or replace as necessary" are warranted for the warranty period. Any warranted part which is scheduled for replacement as required maintenance is warranted for the period of time up to the first scheduled replacement point for that part. Any replacement part, provided it is equivalent in durability and performance, may be used in performance of maintenance or repairs. The owner is responsible for commissioning a qualified technician/mechanic to perform all required maintenance, as outlined in the Inspection, Cleaning, and Maintenance section in this manual.

6. Warranted Parts

1) Fuel Metering System

- i) Carburetor and its internal parts.
- ii) Fuel pump (if so equipped).
- iii) Cold start enrichment system.

2) Air Induction System

- i) Intake pipe/manifold.
- ii) Air cleaner.

3) Ignition System

- i) Spark plug.
- ii) Magneto ignition system.

4) Catalyst System (if so equipped)

- i) Exhaust pipe stud.
- ii) Muffler.
- iii) Catalytic converter (if so equipped).

5) Miscellaneous Items Used in Above Systems

- i) Vacuum, temperature and time sensitive valves and switches.
- ii) Hoses, belts, connectors, and assemblies.



3491 Mission Oaks Blvd. • PO Box 6009 • Camarillo, CA 93011 • (800) 444-3353