

LIFAN
POWER
USA

WWW.LIFANPOWERUSA.COM

PRESSURE STORM



Model LQ-3370
LQ-3370E

Operating Instructions & Owners' Manual

Please read this manual carefully before operating your new pressure washer.
(CA) in the model number designated California Compliant by CARB 4/12/2018



LIFAN POWER USA

WWW.LIFANPOWERUSA.COM

OPERATING INSTRUCTIONS AND OWNER'S MANUAL

Pressure Storm Series LFQ-3370 LFQ-3370E

**PLEASE KEEP AND READ THIS MANUAL
CAREFULLY BEFORE OPERATING YOUR NEW
LIFAN POWER USA DIGITAL INVERTER
GENERATOR**

RECORD PURCHASE HERE

MODEL # _____

ENGINE ID # _____

DATE OF PURCHASE _____

PURCHASE LOCATION _____

**-CA INDICATES THIS UNIT IS
CARB CERTIFIED**

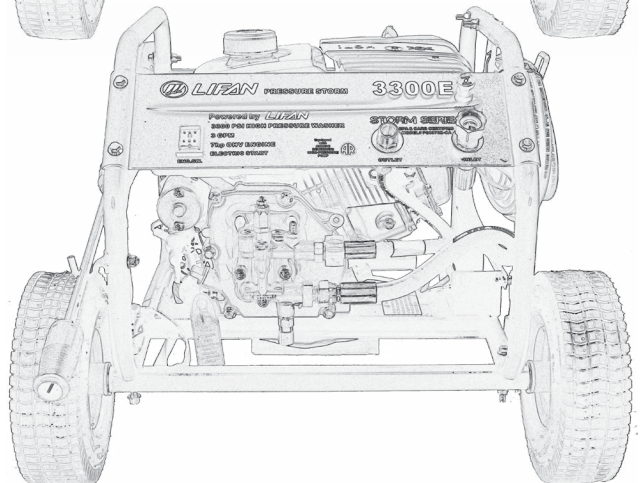
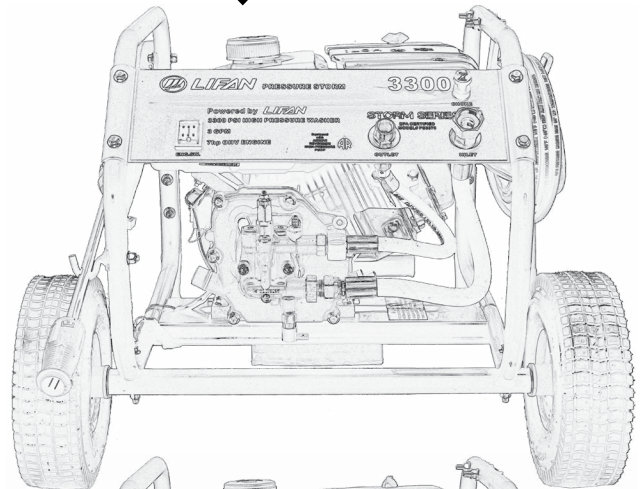



LIFAN POWER USA

ATTENTION: Rental Companies and Private Owners who loan this equipment to others!

All persons to whom you rent/loan this pressure washer must have access to and read this manual. Keep this owner's manual with the inverter generator at all times and advise all persons who will operate the machine to read it. You must also provide personal instruction on how to safely set-up and operate the inverter generator and remain available to answer any questions a renter/borrower might have.

Only Trained Adults should set up and operate this equipment. **DO NOT LET CHILDREN OPERATE THIS EQUIPMENT!**

Always wear safety apparel when operating this equipment, safety glasses, ear protection, insulated waterproof gloves, and non-slip protective shoes are recommended. When using any cleaning chemicals refer to the chemical label for safety instructions concerning those chemicals for use of a respiration mask.

Never operate or let anyone operate this equipment while under the influence of any alcohol, drugs, or medication or when fatigued.

Owner's Manuals are available from Lifan Power USA at
1-866-471-7464.



WARNING

SPECIAL HAZARDS

- **CO Poisoning:** Exhaust from engine contains carbon monoxide, a poisonous gas that can cause carbon monoxide poisoning and possible death if inhaled.
- **Injection Injury:** High-pressure spray can pierce skin and underlying tissues, leading to serious injury and possible amputation. Such an injection injury can result in blood poisoning and/or severe tissue damage.
- **Electric shock:** Operating equipment in wet conditions or near water can cause electric shock.
- **Chemical Exposure:** Cleaning chemical vapors or contact with skin may be hazardous.
- **Fire/Explosion:** Engine sparking can ignite fuel or other flammable liquids or vapors in the vicinity. Hot exhaust from engine can ignite combustible materials.
- **Burns:** Generator engine is a hot surface that can cause burn injuries.

EQUIPMENT PROTECTION FACTS

Inspect Upon Delivery: FIRST! Inspect for missing or damaged components. See “Initial Set-Up/Installation” section for where to report missing or damaged parts.

Water Flow Requirements: Make sure your supply water flow rate is 20% higher than the pressure washer’s flow rate (see “Operations” section for detail), and that your water is clean and particle free.

Do not run Pressure Washer without proper inlet water supply (20 gallons per minute at 20 psi [pounds per square inch]) to high pressure pump and for more than 1 minute without depressing trigger on gun to circulate water to avoid damaging pump.

Chemical Spraying: Use only approved pressure washer chemicals designed for high-pressure use. Use soap adjustment knob to regulate cleaning power (on select units).

Add Engine Oil: Engine is shipped **without oil**. See the “Engine Manual” section of this manual for instructions on capacity and viscosity recommendations.

Maintenance Schedule: Engine requires periodic inspection and servicing to keep generator functioning efficiently. See “Maintenance Schedule Summary” for frequency of servicing.



LIFAN POWER USA

TABLE OF CONTENTS

Preface	6	Operation of Generator	22
Product Specifications	7	Maintenance	25
Safety Instructions	8	Transporting the Unit	30
Controls and Features	11	Storing the Unit	30
PRE-OPERATING INSTRUCTIONS		Troubleshooting	32
Assembly	15	Safety	33
Engine Oil Level Check		Wattage Chart	36
Engine Fuel Level Check		Limited Warranty Policy	40
Air Cleaner Element Check		Appendix: Exploded View / Parts List	44
		Appendix: Wiring Diagram	49

PLEASE READ THE FOLLOWING INSTRUCTIONS!

1. Unit Shipped without engine oil. Axial Cam Pump shipped with correct oil and sealed. See Preoperating Instructions for further information.
2. For repair under Warranty or questions concerning Warranty, DO NOT RETURN this product to the Store where purchased. Follow the procedures as outlined in the "WARRANTY POLICY" and "WARRANTY REGISTRATION" in the Owner's Manual. For any questions visit www.lifanpowerusa.com or call 1-866-471-7464, Option 2 (Warranty and Service).
3. Read the "Owner's Manual" prior to operating any equipment and familiarize yourself with the Proper and safe operation of the equipment. If you have any questions, visit www.lifanpowerusa.com or call 1-866-471-7464, Option 2 (Warranty and Service).



LIFAN POWER USA

PREFACE

Thank you for choosing LIFAN Power USA for your Power Equipment needs. LIFAN Power USA prides itself on providing quality products at affordable pricing, creating the “Best Equipment Value on Today’s Market!”

Your High Pressure Washer utilizes our Industrial Grade Gasoline Engines combined with the premium grade Annovi Reverberi High Pressure Pump to produce a high pressure water spray for cleaning purposes. Do not use this unit for other purposes as unforeseen hazards or equipment damage may result. This unit is intended for **OUTDOOR USE ONLY**.

All LIFAN Power USA products are manufactured utilizing the latest technology. Built with quality components, your new Power Equipment Product will give you years of dependable service. Your unit, along with all of LIFAN Power USA products are designed, engineered, and manufactured with LIFAN’s Industrial Grade Gasoline Engine.

This Owner’s Manual will provide you with all of your needed information for your new Power Equipment Product, including Safe Operation and Maintenance of your unit. Please keep and read this Owner’s Manual completely and carefully prior to operation. Keep this Owner’s Manual for assistance in the future, such as proper maintenance schedules and tips to prolong the life and effective use of your unit. If you require assistance, please visit our website (www.lifanpowerusa.com) or call toll free 866-471-7464 Option 2, Warranty and Service.

This Owner’s Manual contains information with respect to the newest products at the time of publication. Due to revision and modifications, the information noted in the Owner’s Manual might vary from the actual status. This Owner’s Manual is subject to change without notice. The copyright of the Owner’s Manual belongs to EquipSource, LLC. Any group or individual is forbidden to reprint or copy any of this Owner’s Manual without the written consent of EquipSource, LLC.

FOR ALL WARRANTY AND SERVICE RELATED ISSUES/QUESTIONS DO NOT RETURN YOUR UNIT TO THE STORE OR DEALER WHERE THE ITEM WAS PURCHASED. FOR SERVICE VISIT LIFAN POWER USA’S WEBSITE (WWW.LIFANPOWERUSA.COM) OR CALL 1-866-471-7464 Option 2, Warranty and Service. WE WILL BE HAPPY TO HANDLE YOUR WARRANTY ISSUE OR DIRECT YOU TO THE NEAREST “AUTHORIZED SERVICE CENTER.”



LIFAN POWER USA

PRODUCT SPECIFICATIONS

Model/Type	LFQ3370 (-CA)	LFQ3370E (-CA)
Pump Manufacturer	Annovi Reverberi	Annovi Reverberi
Pump Type	RQV	RQV
Pressure Output (psi ¹)	3300 psi	3300 psi
Delivery Output (gpm ²)	3 gpm	3 gpm

ENGINE

Manufacturer	LIFAN	LIFAN
Model	LF170F-BQ	LF170F-BDQ
Maximum Horsepower (MHP)	7 mhp	7 mhp
Engine Displacement	212cc	212cc
Starter	Recoil	Recoil / Electric
Fuel Tank Capacity	1 gallon	1 gallon
Engine Type	4-stroke OHV	4-stroke OHV
Fuel Type	.87 octane gasoline	.87 octane gasoline
Fuel Compliance	10% Ethanol mix or less	10% Ethanol mix or less
Oil Type & Amount	SAE 10W30 20 oz.	SAE 10W30 20 oz.
Low Oil Shutoff Protection	Yes	Yes
CARB Compliant	(-CA) model only	(-CA) model only

DIMENSIONS

Length x Width x Height (inches)	27 in. x 20 in. x 19 1/3 in.	27 in. x 20 in. x 19 1/3 in.
Weight (Lbs.)	82 Lbs.	84 Lbs.

ACCESSORIES

Adjustable Spray Nozzle	Yes	Yes
Gun	Yes	Yes
Outlet Hose	25" PVC high pressure hose	25" PVC high pressure hose
Chemical Injector	1 ea.	1 ea.
Spray Gun & Hose Bracket	Yes	Yes
Mobility / Wheel Kit	Yes	Yes



LIFAN POWER USA

SAFETY INSTRUCTIONS



This is the safety alert symbol. It is used to alert you to potential personal injury hazards. Obey all safety messages that follow this symbol to avoid possible injury or death.

For your safety, read this manual carefully. Become familiar with the proper operation, care, and maintenance of your Stanley product.

The safety and alert symbol () is used with a signal word (CAUTION, DANGER, WARNING), a pictorial and/or safety message to alert you to hazards.

CAUTION indicates a hazard which, if not avoided, could be harmful, or might result in minor or moderate injury.

DANGER indicates a hazard which, if not avoided, will result in death or serious injury.

WARNING indicates a hazard which, if not avoided, could result in death or serious injury.

HAZARD SYMBOLS AND MEANINGS



EXPLOSION



FIRE



ELECTRIC SHOCK



TOXIC FUMES



HOT SURFACE



KICKBACK

DANGER	
Using a generator inside CAN KILL YOU IN MINUTES	
Generator exhaust contains carbon monoxide. This is a poison that you cannot see or smell.	
 NEVER use inside a home or garage, EVEN IF doors and windows are open.	 Only use OUTSIDE and far away from windows, doors and vents.
Avoid other generator hazards, READ MANUAL BEFORE USE	

DANGER	
El uso de un generador en el interior PUEDE MATARLO EN POCOS MINUTOS.	
El escape del generador contiene monóxido de carbono. Esto es tóxico y do debe verlo u olerlo.	
 NUNCA utilice dentro de una casa o un garaje, AÚN cuando las ventanas y las puertas estén abiertas	 Utilice únicamente en el EXTERIOR y lejos de ventanas, puertas o rejillas de ventilación.

DANGER	
L'utilisation d'une génératrice à l'intérieur PEUT VOUS TUER EN QUELQUES MINUTES.	
Les gaz d'échappement de la génératrice peuvent contenir du monoxyde de carbone, un poison que vous ne pouvez pas voir ni sentir.	
 NE JAMAIS utiliser a l'intérieur d'une maison ou d'un garage, MEME SI les portes et fenêtres sont ouvertes.	 Utiliser uniquement à l' EXTERIEUR et loin des fenêtres, portes et ouvertures d'aération.

	WARNING	
<p>Fuel and its vapors are extremely flammable and explosive. Fire or explosion can cause severe burns or death.</p>		



LIFAN POWER USA



WARNING

Running generator emits **carbon monoxide**: an odorless, colorless, **poisonous gas**. Breathing carbon monoxide can cause **nausea or death!**



ONLY operate pressure washers outdoors.

Exhaust gas must be prevented from entering confined areas.

Direct exhaust gas away from windows, doors, ventilation, and other openings.

Do not operate this generator inside or under any buildings.



WARNING

The engine exhaust from this generator contains chemicals known to the state of California to cause birth defects, reproductive harm, and cancer.



WARNING

Rapid recoil of starter cord (kickback) may pull hand and arm forward toward engine at a rapid rate. Broken bones, bruises, sprains, and fractures may result.

WHEN ADDING OR DRAINING FUEL

- Turn pressure washer off and let it cool for at least three minutes before removing fuel cap. Loosen cap slowly in order to relieve pressure in the fuel tank.
- Fill or drain fuel tank outdoors. Do not excessively inhale fuel vapors.
- Keep away from open flames or sparks and other sources of ignition.
- Do NOT smoke while filling fuel tank.
- Do NOT overfill tank. Allow space for fuel expansion.

WHEN TRANSPORTING OR REPAIRING EQUIPMENT

- Transport pressure washer with the fuel valve in the off position.
- Repair pressure washer with the fuel tank empty or the fuel valve in the off position.
- Disconnect spark plug wire before transport or service.

WHEN STORING FUEL OR EQUIPMENT CONTAINING FUEL

- Store away from furnaces, stoves, water heaters, clothes dryers or other appliances that have pilot light or other ignition source because they can ignite fuel vapors.

WHEN STARTING EQUIPMENT

- Ensure spark plug, muffler, air cleaner, and fuel cap are in place.
- Do NOT crank engine with spark plug removed.
- If fuels spills, wait until it evaporates before starting engine.

WHEN OPERATING EQUIPMENT

- Do NOT choke carburetor to stop engine.
- Do NOT tip engine or equipment at an angle, which causes fuel to spill.



LIFAN POWER USA



WARNING



**While engine is running
temperature may exceed
150°F (65°C).
Severe burns may occur.**



WARNING



**Unintentional sparking
can result in fire or
electrical shock.**

CAUTION!

Improper use and care of this pressure washer will cause damage and shorten its lifespan. Failure to follow these actions will void all warranties.

- Use pressure washer only for appropriate and designated purposes.
- The dealer or customer helpline (1-866-471-7464) can instruct you on intended uses.
- Pressure washer must be placed on a level surface.
- Do NOT expose pressure washer to extreme conditions. Excessive dust, moisture, and corrosive vapors will damage unit.
- Engine cooling slots must be kept clear of debris.
- Shut off pressure washer and take to a qualified service center if the unit fails to operate properly.



LIFAN POWER USA

CONTROLS AND FEATURES

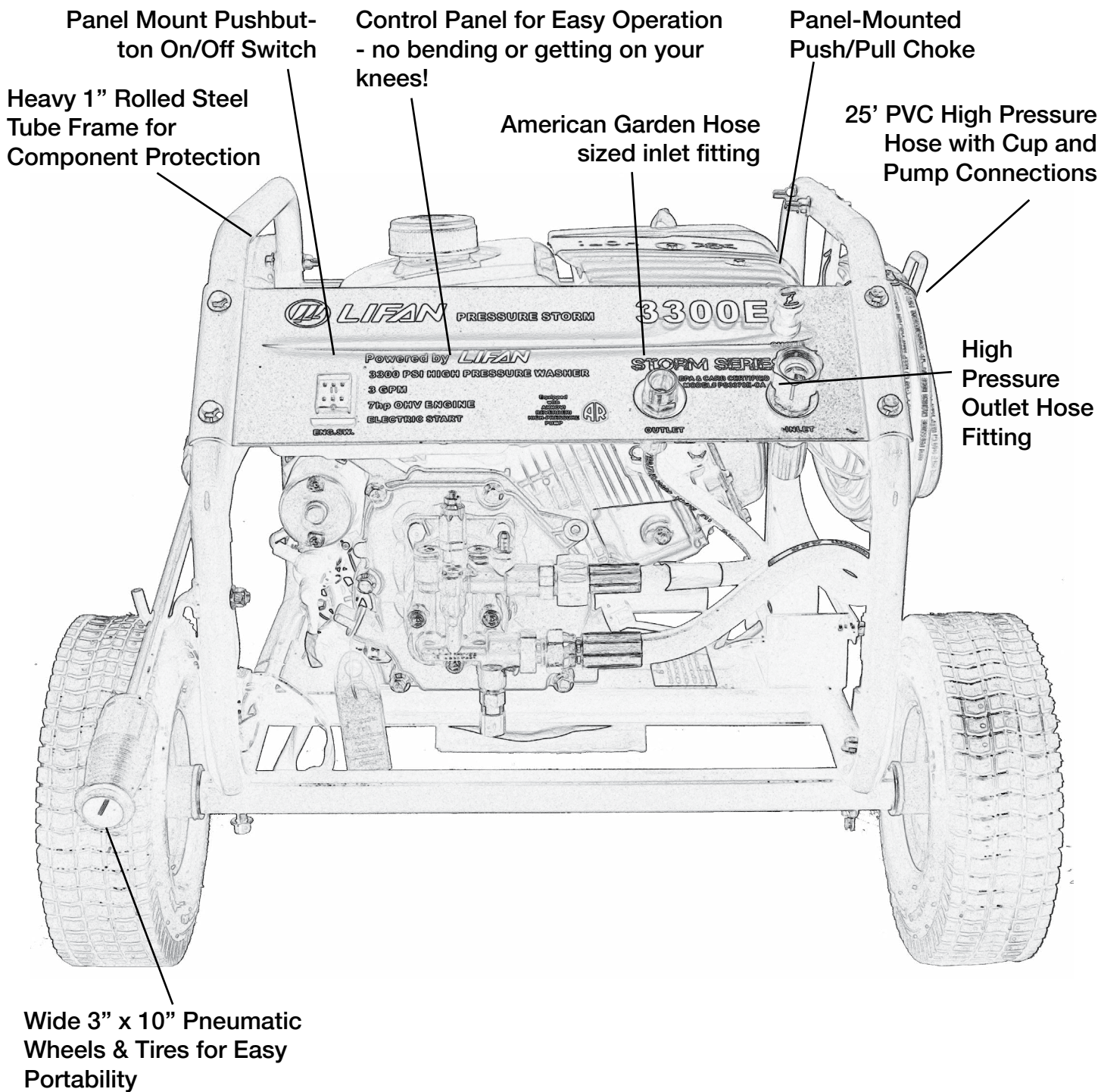



LIFAN POWER USA

CONTROLS AND FEATURES

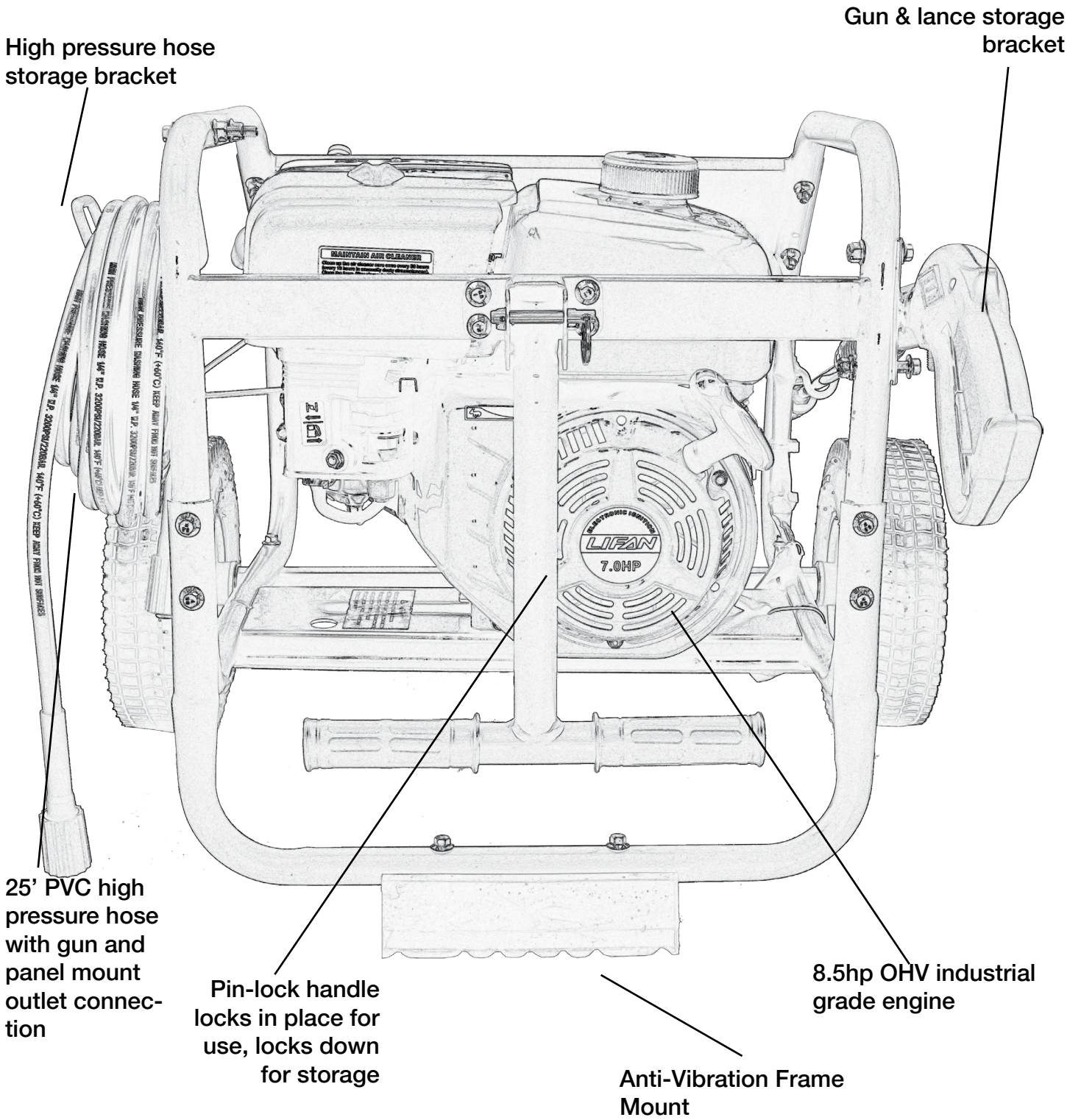

High pressure hose storage bracket

Gun & lance storage bracket

25' PVC high pressure hose with gun and panel mount outlet connection

Pin-lock handle locks in place for use, locks down for storage

Anti-Vibration Frame Mount

8.5hp OHV industrial grade engine



LIFAN POWER USA

CONTROLS AND FEATURES

Heavy 1" Rolled Steel
Tube Frame for
Component Protection

Panel-Mounted
Push/Pull Choke

Annovi Reverberi
RRV High Pressure
Pump

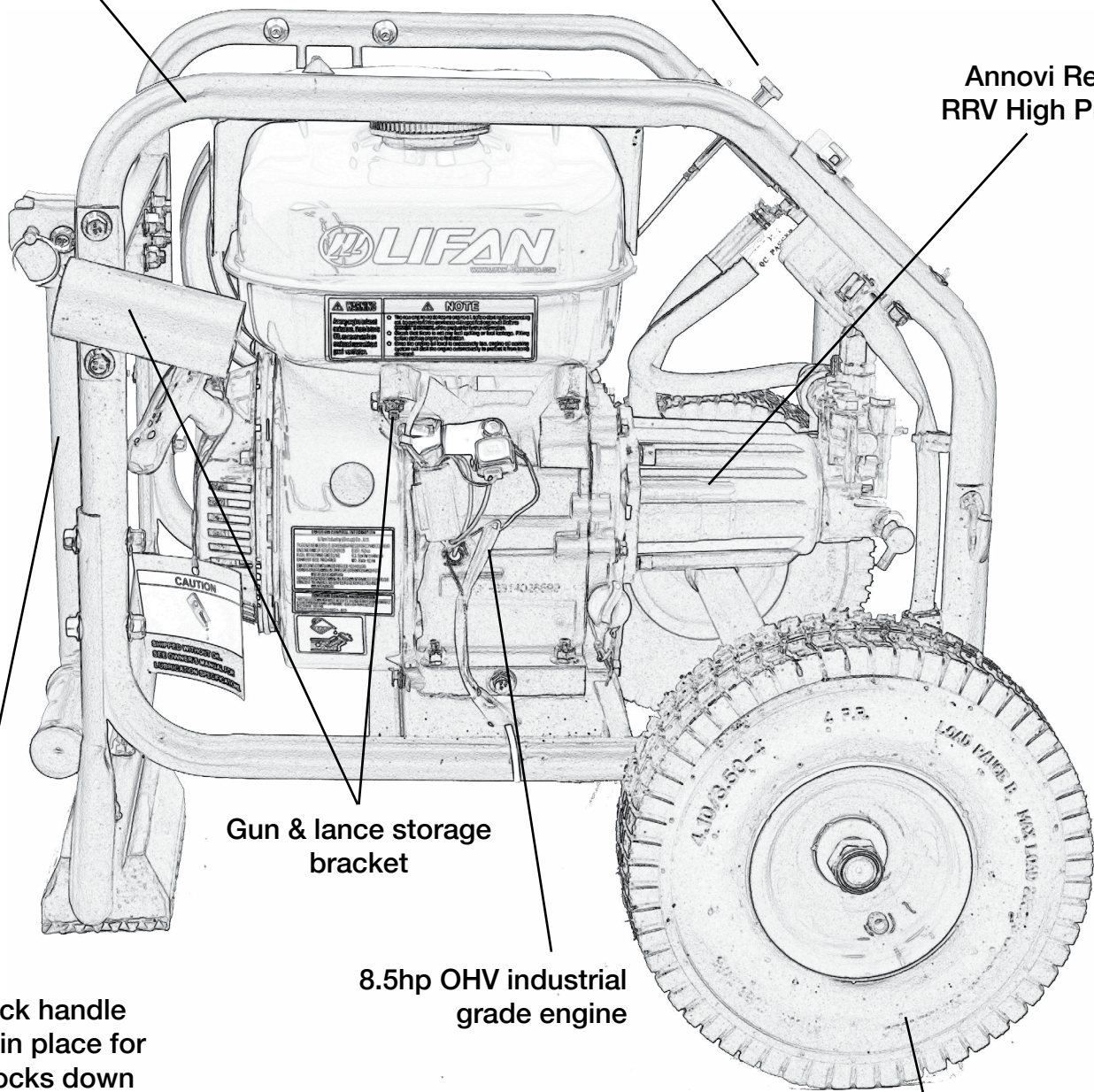

Gun & lance storage
bracket

8.5hp OHV industrial
grade engine

Pin-lock handle
locks in place for
use, locks down
for storage

Wide 3" x 10" Pneumatic
Wheels & Tires for Easy
Portability



LIFAN POWER USA

CONTROLS AND FEATURES

Your LFQ2865 Pressure Washer is designed for convenient connections for the inlet and outlet hose connections on the panel, and is pre-plumbed from the back of the panel to the pump. With the on/off switch (Electric Start Switch on E models) and the Pull to Choke and Push-to-run panel mounted choke, you have everything at your fingertips.



Always check the inlet and outlet connections on the pump and back of panel for leaks or wear.

PRE-OPERATING INSTRUCTIONS: UNPACKING

1. Set the carton on a flat, rigid surface.
2. Remove all loose contents from carton EXCEPT the Engine/Pump/Bottom Frame portion of pressure washer and set them beside carton.
3. Open box completely by cutting each corner from top to bottom.
4. Leave Pressure Washer on the remainder of the box until Wheel Kit is installed. Never attempt to put oil in engine or operate the equipment until fully assembled.
5. Locate all box contents and place them beside the pressure washer. (Some Items may be packaged within the voids of the pressure washer itself.)



LIFAN POWER USA

PRE-OPERATING INSTRUCTIONS: UNPACKING

Your LIFAN Power USA pressure washer is packaged **without fuel and engine oil**.

Some assembly is required before operating your LIFAN Power USA pressure washer.

For further assistance in assembling your pressure washer please visit our website (www.lifanpowerusa.com) or call 1-866-471-7464 during office hours.

BOX CONTENTS:

- Pressure Washer
- Accessory Kit
 - 1 ea. - Spark Plug Removal Tool
 - 1 ea. - Outlet Hose
 - 1 ea. - Lance w/adjustable spray nozzle (Combines with Gun to form Spray Gun)
 - 1 ea. - Gun (Combines with Lance to form Spray Gun)
 - 1 ea. - Spray Gun & Hose Bracket
 - 1 ea. - Chemical Injector Hose
- Owner's Manual
- Warranty Registration Card
- Warranty Policy
- Wheel Kit
 - 2 ea. - Pneumatic Wide Tires and Wheels
 - 2 ea. - Rubber Support Leg
 - 1 ea. - Axle
 - 1 ea. - T-Bar Handle

- Hardware Bag
 - 6 ea. - 12mm Bolt
 - 2 ea. - Handle Bolt (50mm Long)
 - 2 ea. - 3-Point Wing Nut
 - 2 ea. - 14mm Nut
 - 2 ea. - 18mm Nut
 - 2 ea. - Cotter Pin
 - 2 ea. - 1in Washer

INSTALLATION:

The Following Tools are needed to assemble the Pressure Washer:

- Safety Glasses
- 8mm-14mm Wrench Set
- 8mm-14mm Ratchet & Socket Set
- 18mm Ratchet & Socket

For Electric Start model (3370E) only: attach starter wire hanger to handle bolt per picture.

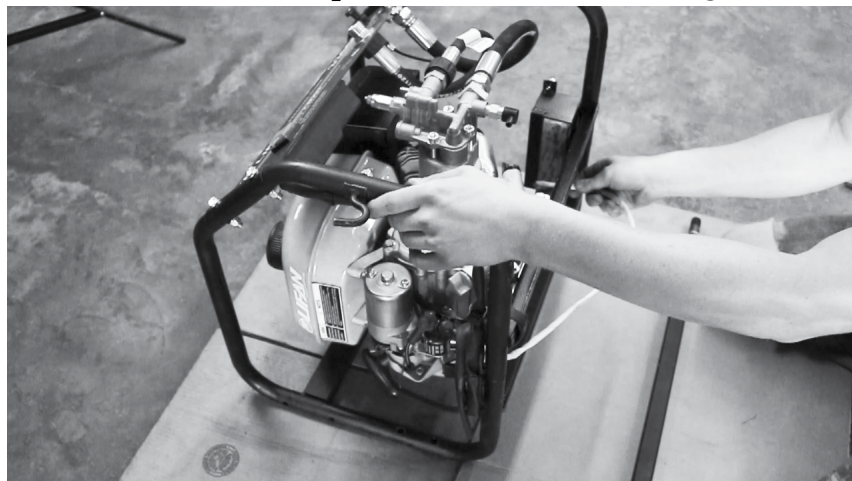



LIFAN POWER USA

PRE-OPERATING INSTRUCTIONS: ASSEMBLY

NOTE: Install Wheel Kit BEFORE Filling the Pressure Washer with Fuel or Oil. Never Tip a Unit that contains Fuel or Oil.

1. Carefully tip pressure washer so the handle end is facing the ground and the pump end is facing the sky.

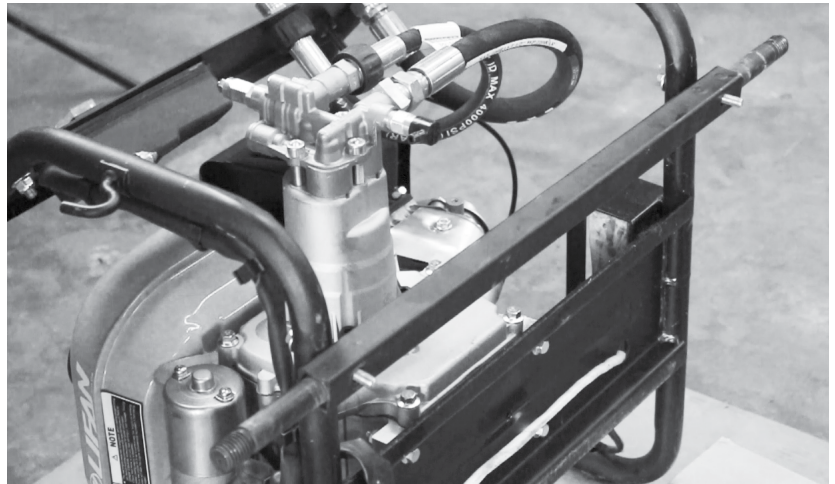
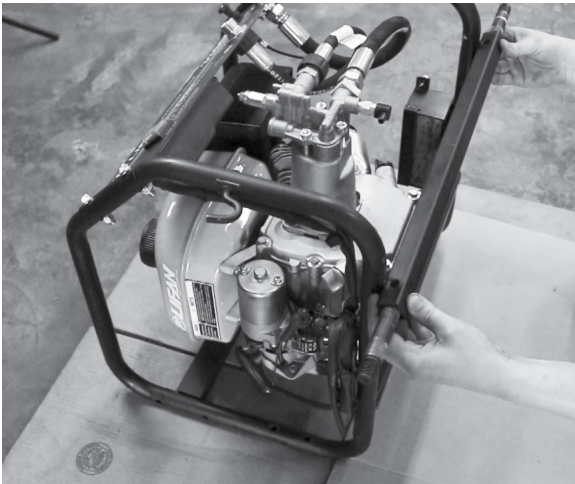

2. Using two 12mm Bolts, attach Axle. Securely tighten using 12mm Ratchet and Socket or like tools.

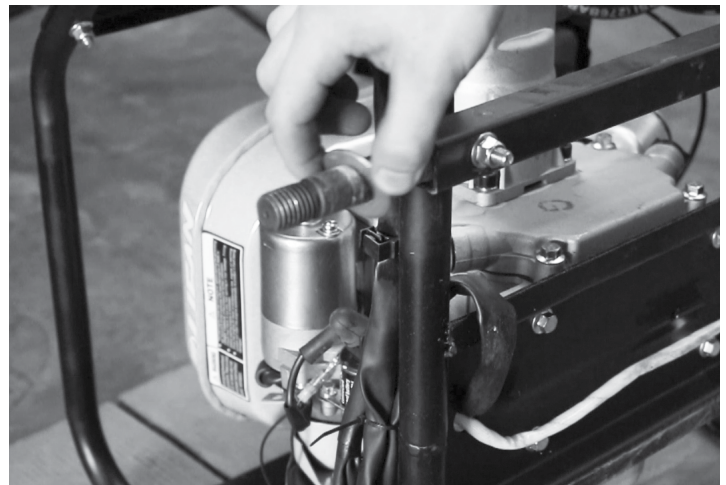
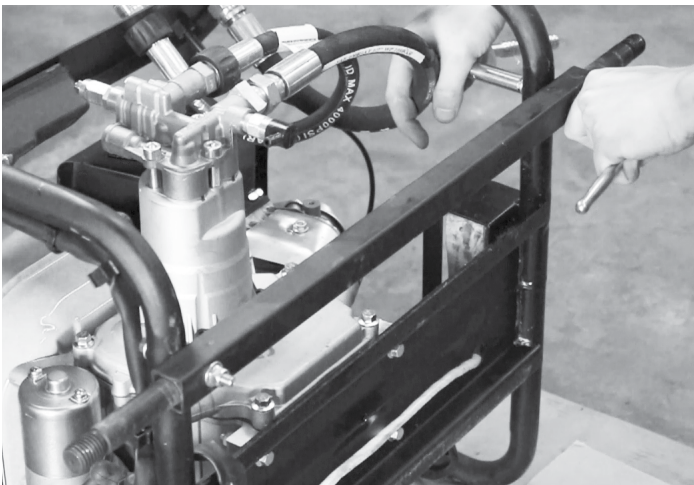

3. Slide 1in. Washer onto each end of the Axle.



LIFAN POWER USA

PRE-OPERATING INSTRUCTIONS: ASSEMBLY

4. Slide Wheel onto each end of the Axle.



5. Securely tighten 18mm Nut to each Axle using 18mm Ratchet and Socket or like tools. Use the included Nyloc wheel nut retainers.



6. Slide Cotter Pin through hole on each end of Axle. Bend the ends of the Cotter Pin to ensure the Cotter Pin will not slip out.



LIFAN POWER USA

PRE-OPERATING INSTRUCTIONS: ASSEMBLY

7. Turn pressure washer over so that pump end is facing the ground and the engine is facing the sky.

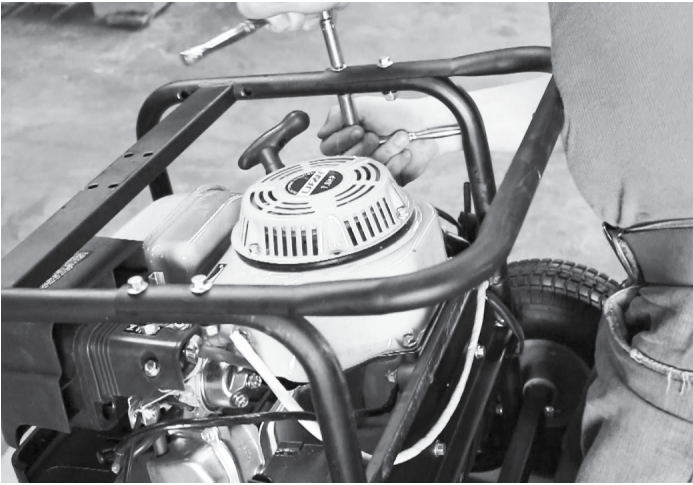

8. Line up the four holes of the support leg with the pre-drilled holes on the pressure washer frame. Using four 12mm bolts, securely attach the support leg to the frame with 12mm Ratchet and Socket or like tools.
9. Attach the rubber foot to the base of the leg using two 18mm bolts with 18mm Ratchet and Socket or like tools. Make sure the bolts are inserted through the base of the foot.



10. Carefully stand the pressure washer up with the wheels and support leg foot touching the ground.



LIFAN POWER USA

PRE-OPERATING INSTRUCTIONS: ASSEMBLY

11. This unit comes with a T-Bar handle. The mount bracket to the frame is pre-drilled and threaded for the 4 bolts to attach the handle.



Handle in down position



Locked in up position



Locked in down position





LIFAN POWER USA

PRE-OPERATING INSTRUCTIONS: ASSEMBLY

12. **For Electric Start model only (3370E):** The Battery box is located on the frame rail. Install Red (Hot) Lead to Positive Post and Black (Ground) to Negative Post pre wired to the electric starter on the engine.

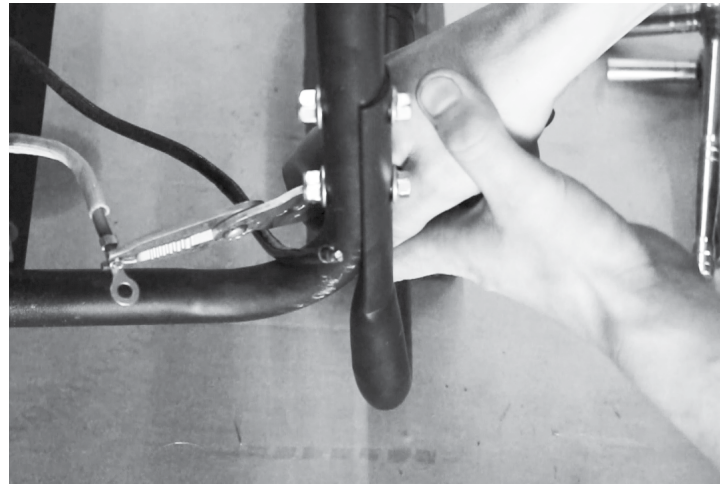



LIFAN POWER USA

PRE-OPERATING INSTRUCTIONS: ASSEMBLY

13. Slide the Spray Gun & Hose Bracket through the holes on the Handle. Securely tighten using the 14mm nuts and a 14mm Ratchet and Socket or like tools.

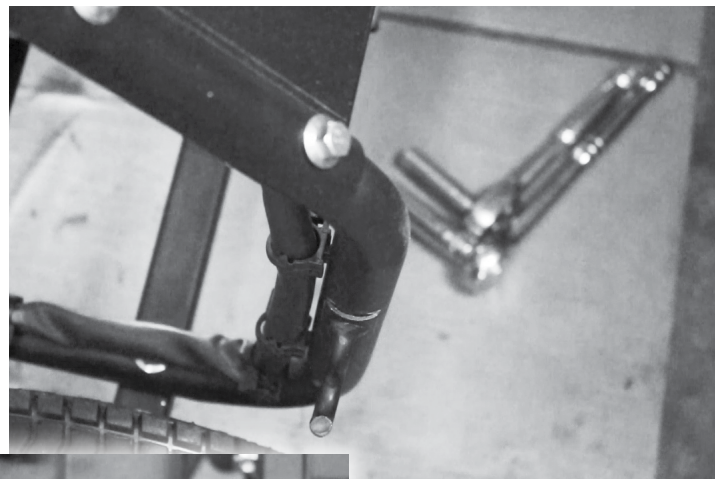
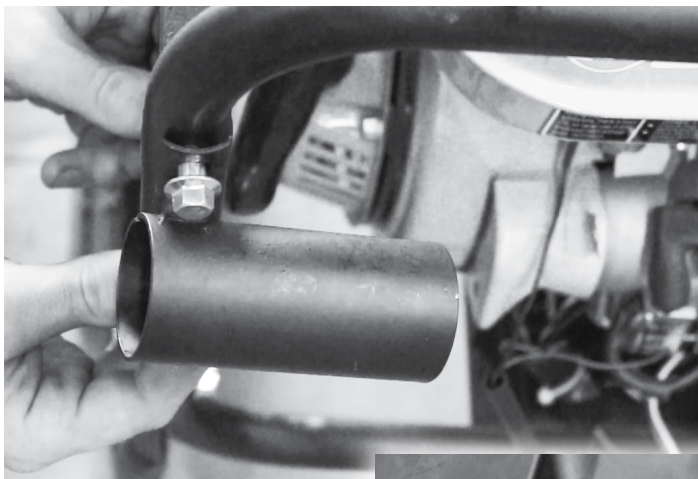

14. Screw the Lance with adjustable spray nozzle and Gun together to form Spray Gun.

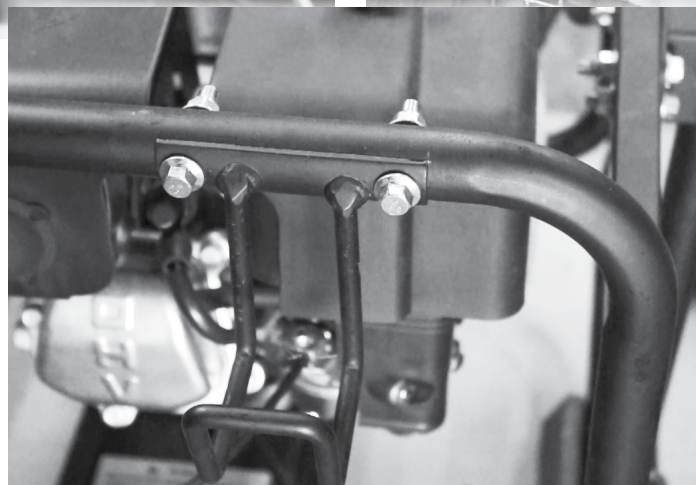

15. Place Spray Gun in the Spray Gun bracket; hang the high-pressure hose on the hose bracket.

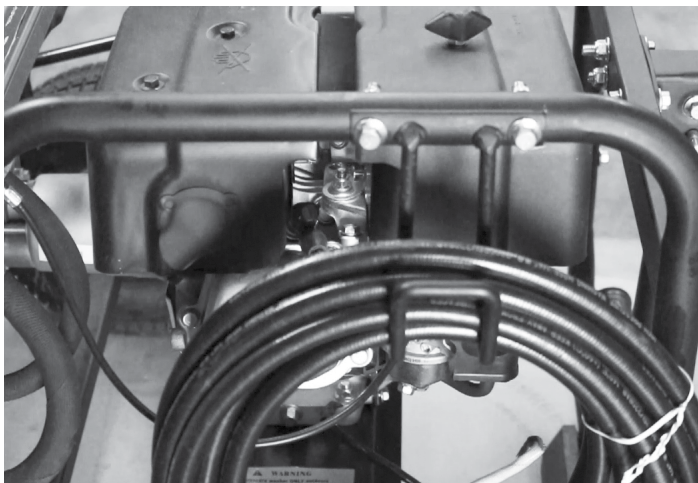



LIFAN POWER USA

PRE-OPERATING INSTRUCTIONS: SETUP

ENGINE OIL LEVEL CHECK

CAUTION: Any attempt to start the pressure washer before it has been properly serviced may result in engine failure and void warranty.

CAUTION:

- Running engine with insufficient engine oil can cause severe damage to the engine.
- The engine performance and service life is directly dependent of the quality of the engine oil.
- Check engine oil level only with engine stalled and with unit on level ground.
- Use 4-stroke gasoline engine oil equivalent in quality with SF, SG from API.

Oil viscosity varies with average environmental temperature.

Select engine oil with proper viscosity using the chart to the right in accordance with your regional environmental temperature.

Engine Oil Alarm System

The engine oil alarm system aids in avoiding engine damage due to improper amounts of engine oil in the crankcase. Before the engine oil in the crankcase drops below the safety line, the engine oil alarm system will automatically stall the engine (while the engine switch remains in the "ON" position).

If the engine stops and will not restart:

1. Remove the oil dipstick and wipe it clean.
2. Insert the dipstick into engine oil filler hole without screwing it in.
3. Remove dipstick and check engine oil amount.
4. If engine oil is below required amount, fill specified engine oil up to the top of filler hole. Use engine oil dependent on environmental temperature.
5. Reinstall the engine oil dipstick.

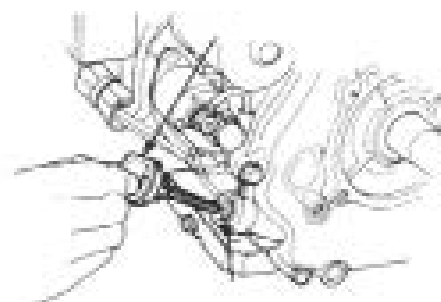
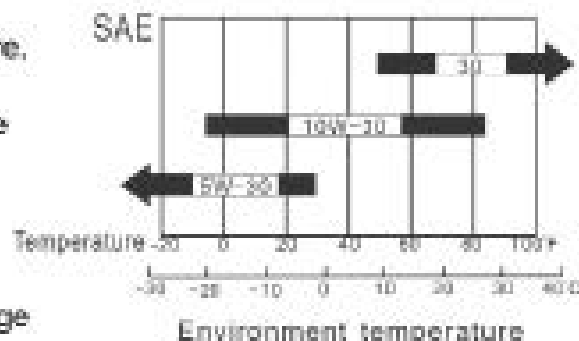



LIFAN POWER USA

PRE-OPERATING INSTRUCTIONS: SETUP



WARNING



Fuel and its vapors are extremely flammable and explosive. Fire or explosion can cause severe burns or death.

WHEN ADDING FUEL

- Turn engine off and let it cool for a minimum of three minutes before removing fuel cap.
- Turn and remove cap slowly in order to relieve residual tank pressure.
- Always fill the fuel tank with the unit outdoors.
- DO NOT overfill tank. Allow room for fuel expansion.
- Keep fuel away from sparks, open flames, heat, pilot lights, and other ignition sources.

ADD FUEL: Refer to Controls and Features section for diagrams.

1. Clean area around fuel cap, then remove fuel cap.
2. Pour fresh, clean regular automotive grade unleaded fuel with a minimum octane rating of 85 into fuel tank. Do NOT mix fuel with oil. Fuel must have ethanol blend of 10% or less. Pay close attention to the storage requirements of these fuels. Do NOT overfill fuel tank.
3. Install the fuel cap. Rotate the fuel cap clockwise until it is in its locked position. Wipe away any spilled fuel.
4. Open vent on gas cap

CAUTION: Alcohol-blended fuels (gasohol, ethanol, or methanol) will attract moisture, which leads to separation and formation of acids during storage. Acidic gas can damage the fuel system of an engine while in storage. To avoid engine problems, the fuel system should be treated with a fuel stabilizer or drained if the generator will not be started for thirty (30) days. If using a fuel stabilizer, follow the manufacturer's recommended instructions for use.

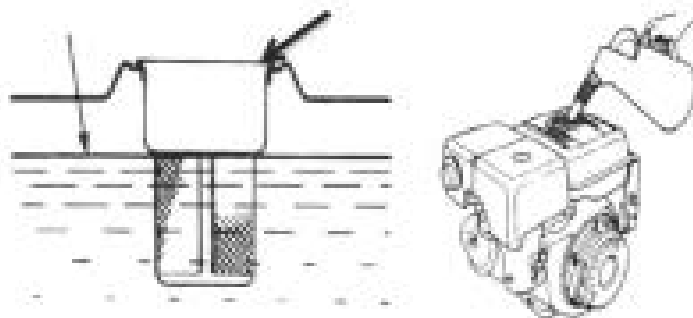



LIFAN POWER USA

PRE-OPERATING INSTRUCTIONS: SETUP

CAUTION: Do NOT run the engine without air cleaner element installed. Operation of engine without air cleaner element installed will result in the inhalation of dirt, dust, and other debris into the engine and through the carburetor. This will result in premature wear of the engine. Any attempt to start the pressure washer before it has been properly serviced may result in engine failure and void warranty.

To Check Air Cleaner Element:

1. Remove the wing-nut from the top of the air filter housing and remove top.
2. Remove the wing nut from the air filter and check for debris or stoppage. If dirty replace with the correct Air Filter for your unit. They are available at your dealer or from LIFAN Power USA. Order your filter by calling toll free 866-471-7464.
3. Re-Install the air filter element into the air filters housing and re-attach the air box top, tighten wing nut to firm.

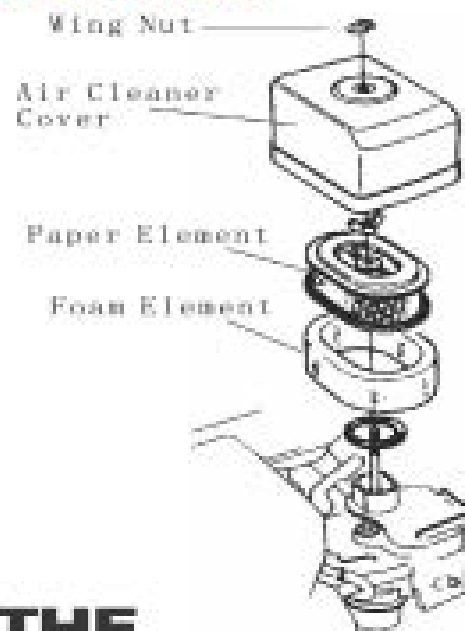

CONNECTING THE INLET / OUTLET HOSES

Use only provided hoses or replacement hoses equal in quality. Use of improper hoses may result in injury. Check hose for worn spots or leaks.

Leak →
Worn Area, hose reinforcement shows →

Use of chemical hose required only if cleaning agents are applied during washing. Adjustable spray wand must be adjusted to least pressure to siphon chemicals. Ensure each hose connection is tightly secured. Failure to do so may result in injury or damage to the unit.

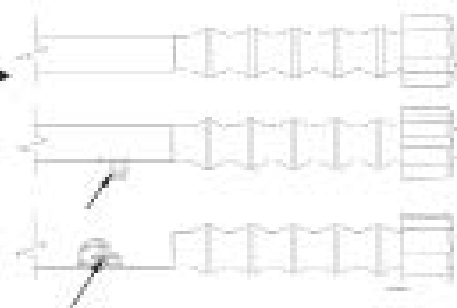



LIFAN POWER USA

CONNECTING THE INLET / OUTLET HOSES

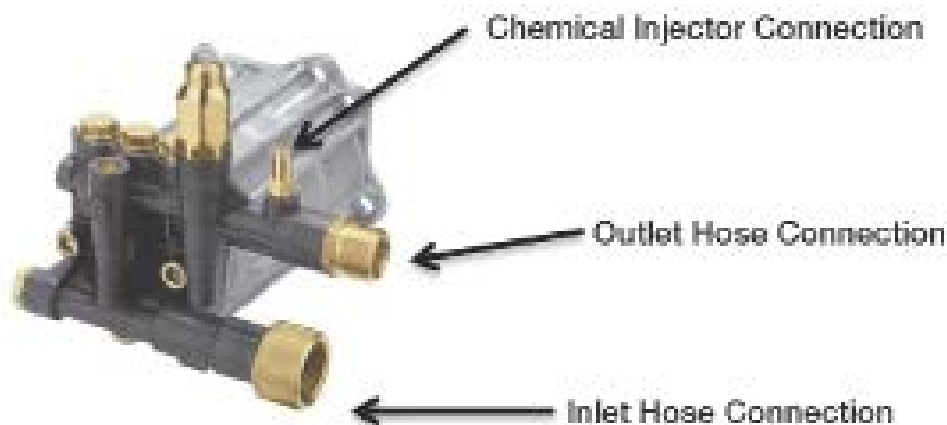

CONNECTING INLET HOSE:

1. Connect Inlet Hose to Inlet Hose Connection on pump. Tighten securely.
2. Connect alternate end of Inlet Hose to a water tap. The water tap must deliver at least 20psi (pounds per square inch).
3. An insufficient water supply will damage your pump. Make sure the water supply is steady and is 20% over the rated flow of your pump.

NOTE: Under NO circumstance should the pressure washer be used as a self-prime from a water vessel.

CONNECTING OUTLET HOSE:

Outlet Hose must be a High Pressure Hose. **NOTE:** the Outlet Hose (High Pressure Hose) provided is the BLACK hose. The outlet or high pressure hose must be checked for any wear or leakage. Replace any damaged high pressure hoses.

1. Connect the Outlet Hose to Outlet Hose Connection on Pump. Tighten securely.
2. Connect alternate end of Outlet Hose to Spray Gun as shown here. Tighten securely.

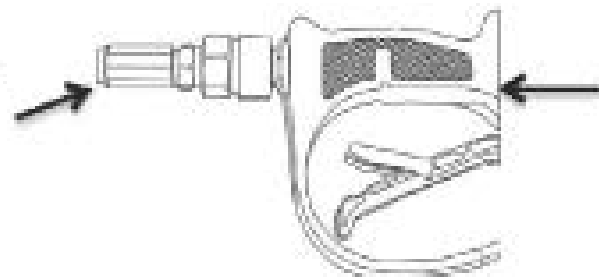



LIFAN POWER USA

CONNECTING THE CHEMICAL INJECTOR HOSE

The Water to Chemical ratio is 7:1.

NOTE: The Chemical Injector Hose provided is the white/clear hose and should be used in unison with the Spray (black) Nozzle.

CAUTION: WHEN USING CHEMICALS OR CLEANING SOLUTIONS:

- Use low pressure setting only for chemicals.
- Use ONLY soaps and chemicals designed for pressure washer use.
- Do NOT use bleach.
- Ensure water to chemical ratio is 7:1.
- Ensure chemicals are NOT allowed to remain in pump after use. Failure to clean chemicals out of pump will damage unit and void warranty.

1. Connect the Chemical Injector Hose to the Chemical Injector Connection on Pump. Tighten Securely.
2. Place alternate end of Chemical Injector Hose into chemical/cleaning solution to be used. This end of the Chemical Injector Hose will have a filter to keep foreign debris from entering pump.
3. After use of Chemicals/Cleaning Solutions, place the end with the filter of the Chemical Injector Hose in clean water and allow to operate for three (3) minutes to clean excess chemicals from pump housing.

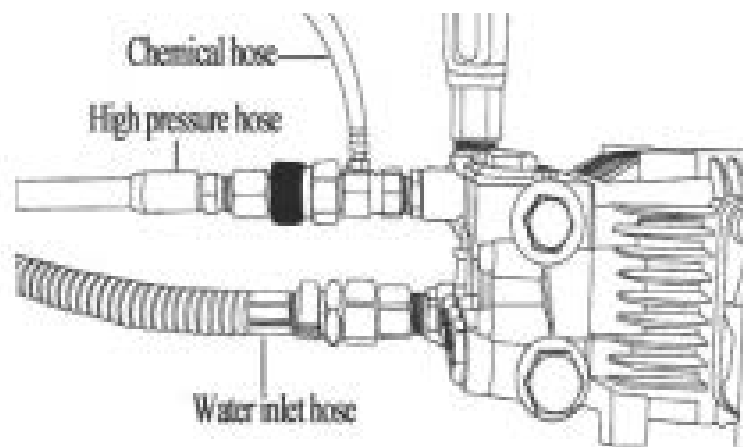

NOTE: Chemicals will NOT siphon while Spray Wand is in High-Pressure settings.



LIFAN POWER USA

OPERATION OF PRESSURE WASHER



WARNING

Pressure Washer Use Location

Running pressure washer gives off carbon monoxide gas. It is odorless, colorless, and highly toxic. Breathing carbon monoxide gas can lead to fainting, nausea or may result in death.

- Only operate pressure washer outdoors.
- Prevent exhaust gas from entering, through windows doors or ventilation intakes, any confined areas.
- DO NOT operate pressure washer inside any enclosed or roofed areas.

BEFORE OPERATING PRESSURE WASHER: Refer to Pre-Operating Instruction section for additional procedures and definitions.

1. Check pressure washer condition.
 - a. Inspect for signs of damage, oil or fuel leaks.
 - b. Remove excessive dirt and/or debris from the unit.
2. Check Inlet, Outlet, and Chemical Injection Hoses.
 - a. Inspect general condition of hoses to ensure hoses are in serviceable condition.
 - i. Outlet Hose must be constructed to withstand High-Pressure.
 - b. Ensure hoses and nozzles are securely installed.
3. Check the Engine.
 - a. Ensure proper engine oil amount.
 - b. Ensure air cleaner element is clean and installed.
 - c. Ensure proper fuel level amount.
4. Ensure pressure washer is on a level surface.
5. Ensure engine switch is in the "OFF" position.
6. Ensure pressure washer is at least 7ft away from building walls and other equipment during operation. Do NOT place flammable objects close to pressure washer.
7. Always operate within the length of your water hose for inlet pressure.
8. Do not operate with any tarps, covers, and any objects on top of the unit.
9. Exhaust gas is hot and can cause combustible materials around your unit to ignite, make sure unit is not operated within 7 feet of any combustible materials and always keep a properly charged fire extinguisher and be familiar with the use of the fire extinguisher.



LIFAN POWER USA

OPERATION OF PRESSURE WASHER

STARTING THE ENGINE:

Do not run Pressure Washer without proper inlet water supply to high pressure pump and for more than 1 minute without depressing trigger on gun to circulate water to avoid damaging pump.

Refer to the Controls and Features section for additional diagrams and definitions.

1. Depress the Spray Gun trigger.
2. Move the fuel cock to the "ON" position.
3. To start a cold engine, place the choke lever in the "OFF" position. For LEVER mounted choke pull to choke. To restart a warm engine, leave the choke level in the "ON" position.
4. Move the throttle valve lever away from the "LOWER" position, about 1/3 of the way toward the "UPPER" position.
5. Place the throttle lever halfway between the "UPPER" and "LOWER" settings.
6. Place the engine switch to the "ON" position.
7. Pull the recoil starting handle lightly until resistance is felt, then pull briskly. Do NOT allow the starter handle to snap back against the engine. Return it gently to prevent damage to the starter.
8. For electric start models, equipped with a key switch turn the switch to the ON position, for models with the rocker switch start, push the rocker switch to the ON position. Hold the key in the start position or the rocker arm in start position until the engine starts or for no more than 10 engine rotations. If the engine does NOT start, wait 15 seconds and repeat starting procedures.
9. After starting the engine, move the throttle lever to the "UPPER" position for self-priming.

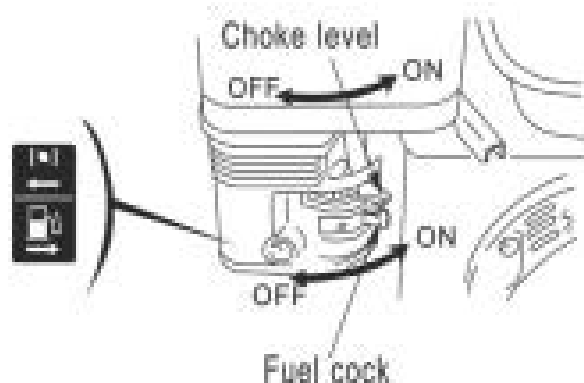
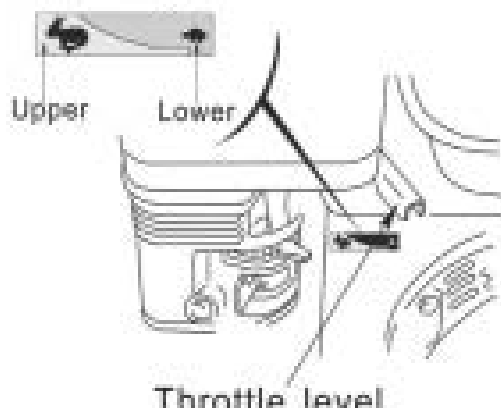



LIFAN POWER USA

OPERATION OF PRESSURE WASHER

PRESSURE WASHER OPERATION:



CAUTION

- Avoid contact of high-pressure water exiting spray gun with humans or animals. See "Rules for Safe Operation" for medical information.
- Use proper pressure setting to avoid damage of cleaning surface.
- Point tip of spray gun toward cleaning surface and depress trigger.
- Do not run Pressure Washer without proper inlet water supply to high pressure pump and for more than 1 minute without depressing trigger on gun to circulate water to avoid damaging pump.

ADJUSTING PRESSURE OUTPUT: The pressure setting is preset at time of manufacturing to provide optimum pressure and cleaning.

TO LOWER PRESSURE:

- Increase the distance between the Spray Gun and the surface being cleaned.
- Reduce the speed of the engine by moving the throttle lever toward the "LOWER" setting.
- Adjust the adjustable spray tip to a wider water fan and less pressure.
- Adjust the Pressure Regulator Knob on the pump. Turn counterclockwise to lower pressure output. After use, return the Pressure Regulator Knob to its original position.





LIFAN POWER USA

OPERATION OF PRESSURE WASHER

STOPPING THE ENGINE:

Refer to the Controls and Features section for additional diagrams and definitions.

IN AN EMERGENCY:

1. Turn the engine switch to the "OFF" position.
2. Turn the inlet water supply to the "OFF" position.
3. Depress gun trigger to expel remaining pressurized water.

NORMAL PROCEDURE:

1. If the chemical injection hose was used with chemicals, allow pressure washer to operate for three (3) minutes while in-taking clean water through chemical injection hose.
2. Move the throttle valve lever to the "LOWER" position.
3. Turn the engine switch to the "OFF" position.
4. Turn the fuel cock to the "OFF" position.
5. Depress the spray gun trigger.



LIFAN POWER USA

TRANSPORTING AND STORING THE UNIT



CAUTION

- To avoid fire, allow unit to cool down for at least twenty (20) minutes before transporting or storing the unit.
- Always transport and store the unit with the fuel cock in the "OFF" position.
- Always keep unit in horizontal position to the ground to prevent fuel from spilling. Spilled gasoline and gasoline vapor may ignite.
- Gasoline is extremely flammable and explosive.

STORING THE PRESSURE WASHER: Refer to the Controls and Features section for additional diagrams and definitions.

1. Ensure the storage site for the unit is clean and dry.

Before long term storage of your power equipment product, typically 30 days or more, perform the following:

2. Set the fuel cock (valve) to the "OFF" position.
3. Let the unit continue to run until it stops itself, burning all of the fuel in the fuel system. Keep inlet water supply to pump and continue to use the spray wand with the trigger depressed to keep water circulating in the pump and to expel pressurized water.
4. Turn the ignition switch to the "OFF" position.
5. Drain the engine oil in accordance with the "Engine Oil Change Procedures" in this Owner's Manual's Maintenance section. Do NOT re-fill with oil until ready to use again.
6. Remove the Spark Plug in accordance with the "Spark Plug Maintenance" in the Owner's Manual's Maintenance section. Spray a lubricant, such as WD40®, into the Spark Plug hole to lubricate the top of the piston and walls of the cylinder. Replace the Spark Plug.
7. Pull starter rope until resistance is felt. This will place the valves in the closed position.
8. Add the recommended amount of fuel stabilizer, in accordance with the amount recommended by the manufacturer of the fuel stabilizer, to the unused gasoline left in the unit's tank.
9. Place the unit in a clean, dry, and secure location.
10. Cover the unit to protect from dust.
11. If stored in freezing conditions you can utilize a short garden hose and a funnel to install anti-freeze into the inlet connection on the pump.



LIFAN POWER USA

MAINTENANCE

MAINTENANCE SCHEDULE	
PROCEDURE	TIME
Engine Oil Check	Each Use
Replace Engine Oil	After Each 40 Hours of Use (For Initial Break in – After First (1st 10 Hours of Use)
Air Cleaner Filter	Check Each Use/Replace As Needed or After Every 100 Hours of Use
Impeller Check	After 300 Hours of Use or After First Year
Air Cleaner Wash	When Needed or Max 50 hrs run time
Spark Plug	When Needed or Max 100 hrs run time
Valve Clearance	Check & Re-adjust annually or after 300 Hours of Use
Fuel Tank	Replace Every 3 Years Based on Condition

NOTE: Refer to Following Procedures for Proper Method to Perform Maintenance

ENGINE OIL CHANGE PROCEDURES: Do not run without proper water supply to high pressure pump to avoid damaging pump.

Periodic Maintenance of your engine oil should be performed after each 40 hours of use of your Power Equipment Product. Check your engine oil level prior to each use.

1. Start your engine and let it warm up to get the oil warm and thinner. After warm up turn engine off. Be sure during warm up sufficient inlet water is supplied to unit and gun trigger is depressed to avoid damage to the pump. Remove the dipstick (Refer to Controls and Features section) by turning counter clockwise. Remove the oil drain plug (Refer to Controls and Features section) located below the dipstick utilizing the appropriate tools. During warm up on pressure washer always supply inlet water and depress spray gun to circulate water in pump to avoid damage to pump. **CAUTION: THE OIL MAY BE HOT**
2. Drain the engine oil into an approved receptacle and discard in accordance with all Federal and State Regulations. Never dump your used engine oil on the ground or into drains, only discard in an approved manner. Check with your local authorities to determine the regulations in your area. **WARNING! AVOID SPLASHING OF HOT OIL; IT CAN BURN YOU AND CAUSE SEVERE INJURY.**
3. After oil is completely drained, replace oil drain plug and tighten with appropriate tools. Replace oil with the proper oil for your product. Refer to the Pre-Operating Instructions: Engine Oil Level Check section for exact fill requirements. Always use your dipstick to check the oil level and only fill to the full mark on the dipstick. Never overfill the engine, as this can cause damage to the unit and void warranty.
4. Replace the dipstick on your engine.

PROPER MAINTENANCE OF YOUR UNIT WILL INCREASE THE LIFE OF YOUR PRODUCT. THE OIL MUST BE CHANGED ON A REGULAR BASIS FOR PROPER OPERATION, AND RELIABILITY AND TO ALSO MAINTAIN YOUR WARRANTY ON THIS PRODUCT.



LIFAN POWER USA

MAINTENANCE

SPARK PLUG MAINTENANCE:

1. Remove Spark Plug Cap.
2. Remove Spark Plug with socket and handle supplied with your unit.
3. Clean any carbon build-up around the Spark Plug.
4. Check the Spark Plug Gap and adjust if necessary. 0.028-0.031 inch gap.
5. Lubricate the threads of the spark plug with anti-seize compound or engine oil.
6. Re-install the Spark Plug and Spark Plug Cap.

Spark Plug Removal Tool



FUEL SYSTEM MAINTENANCE:

NOTE: Periodically you can get sediment or trash in your Carburetor Bowl. Use the following procedures to clean:

1. Turn the fuel cock (valve) to the "OFF" Position.
2. Remove the carburetor bowl by removing the mounting bolt located at the bottom of the bowl.
3. Dump out the old fuel and sediment into an approved container.
4. Clean carburetor bowl thoroughly.
5. Fit a new rubber washer into place and re-attach fuel bowl to the carburetor. **NOTE:** Removal of the drain screw at the bottom of the bowl can drain the fuel to remove smaller debris that has collected in the bowl.
6. After bowl is securely back in place, turn the fuel cock to the "ON" position for use.

Units equipped with a pre-filter for fuel will have a filter housed just below the fuel cock. Remove the fuel filter element and clean or replace the fuel filter element (diagram below).



Fuel Filter
Element Removal

**If the generator has
been running, the
muffler will be very hot.
Allow it to cool before
proceeding.**



Fuel Filter
Element Assembly



LIFAN POWER USA

MAINTENANCE

Muffler Maintenance: Every 50 hours of operation remove the Spark Arrestor per the diagram below and clean or replace.

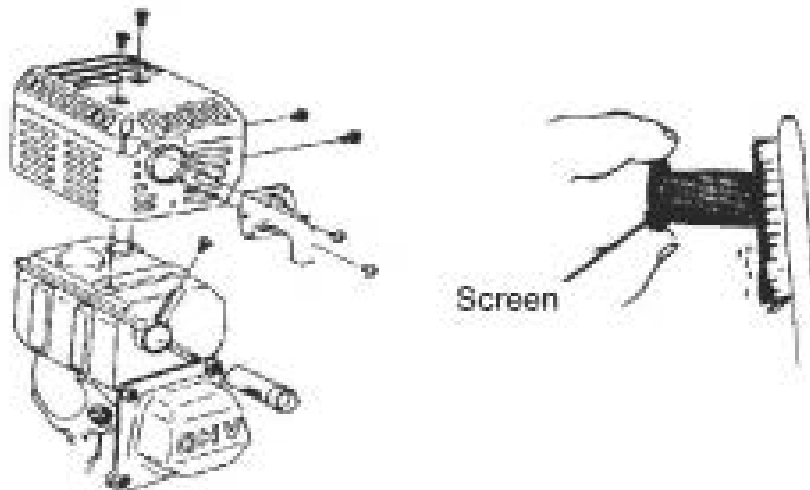

ANNOVI REVERBERI AXIAL CAM PUMP:

Unit undergoes extensive testing at the time of manufacturing. Lifetime oil is installed in pump and pump is sealed. Pump oil will NOT have to be checked or changed. Pump under warranty by manufacturer. Refer to Warranty Policy for details.

Do not run Pressure Washer without proper inlet water supply to high pressure pump and for more than one minute without depressing trigger on gun to circulate water to avoid damaging pump.

USAGE IN HIGH ALTITUDE REASONS

In regions with high altitude, the standard carburetor produces overly dense combinations of fuel and air, which result in decreased engine performance and increased fuel consumption. To maintain high engine performance at high altitudes, install a high altitude carburetor main spray nozzle and re-adjust the adjusting screw for idle speed. For usage in regions with an altitude over over 4,527 ft. (1380m), contact your dealer to replace the standard carburetor and make needed adjustments in advance. Even with a proper high altitude carburetor spray nozzle installed in the engine, the power output of the engine will drop about 3.5% with every 1000 ft. (305m) increase in altitude. If the standard carburetor jets are not replaced and adjusted for usage in high altitude, the increase altitude effect will be even more severe.

NOTE: Usage of the water pumps in regions with lower altitude than the high altitude carburetor spray nozzle is applicable, may result in decrease of engine performance. The engine may become overheated and over-lean combination of fuel and air produced, may cause severe damage to the engine.



LIFAN POWER USA

TROUBLESHOOTING

IF THE ENGINE WILL NOT START:

1. Check to ensure switches are in the "ON" position.
2. Check engine oil level. The unit possesses a Low Oil Shutdown feature that will not allow your engine to start if the oil is below safe operating levels. This feature is installed to increase the life of your engine and prevent engine damage. If oil level is low, fill to the full mark on dipstick. Refer to the Pre-Operating Instructions: Engine Oil Check section for exact oil type and amounts.
3. Check the fuel level to insure adequate fuel. Add fuel if necessary.
4. Remove and inspect the spark plug for cleanliness and proper electrode gap. If needed, clean or replace the spark plug. Refer to Spark Plug Maintenance in the Maintenance section of the Owner's Manual for proper procedure.
5. If the unit will still NOT start after performing the above checks, call our customer hotline at LIFAN Power USA Toll Free 1-866-471-7464 or take the unit to an authorized Service Center.

NOTE: Periodically on the initial start-up or after the unit has been stored for a long period of time, the float for your "Low Oil Shutdown" system will stick to the bottom of the oil pan. Locate the two (2) wires to the Low Oil Sensor Diode (seen at right) located on the side of the engine block. Unplug these wires and, only after ensuring the engine is full of oil, start the engine and allow to run until warm (normally 20 minutes, as this will heat the oil and release the float on the Low Oil Shutdown System). Then re-plug the wires to the terminals on the Low Oil Shutdown Sending Unit.



IF WATER IS LEAKING:

- Ensure Outlet Hose is securely tightened.
- Ensure Inlet Hose nut is securely tightened.
- Call dealer for repair if pump housing is leaking.



LIFAN POWER USA

TROUBLESHOOTING

IF ABNORMAL NOISE FROM PUMP HOUSING:

- No water inside pump – Ensure Inlet Hose is connected and supplying recommended supply of water to pump. Check to see if the inlet hose is kinked.

IF NO WATER EXITING FROM SPRAY WAND:

- Ensure Inlet Hose is NOT clogged or kinked.



LIFAN POWER USA

PRESSURE WASHER SAFETY

1. Never operate a gasoline engine powered product in any enclosed spaces, as they product deadly Carbon Monoxide Poisonous Gases.
2. Do NOT operate your power equipment in inclement weather such as rain, snow, and/or sleet.
3. Do NOT operate your power equipment within seven (7) feet of any flammable materials.
4. When refueling your power equipment never smoke or refuel near any flame or ignition devices. Never refuel while the unit is running. If during the refueling process some fuel is spilled, always completely clean the fuel and allow sufficient drying time prior to re-starting your unit. Gasoline vapors ignite easily and are very dangerous.
5. NEVER ALLOW CHILDREN OR ANIMALS TO BE NEAR THIS EQUIPMENT DURING OPERATION. ONLY QUALIFIED PERSONS SHOULD OPERATE THIS EQUIPMENT. PLEASE FOLLOW ALL GUIDELINES CONTAINED IN THIS OWNER'S MANUAL FOR THE SAFE OPERATION OF THIS EQUIPMENT.



LIFAN POWER USA

SAFE OPERATION

Follow Safety Rules for Operation

After you have checked and fueled the equipment and positioned it in a suitable worksite, it is time to start your pressure washer. The following are the procedures necessary for safe, successful operation of your pressure washer.



WARNING: Failure to follow safety rules may result in serious injury or death to the operator or bystanders.

Instruct operators. Owner must instruct all operators in safe set-up and operation. Do not allow anyone to operate the pressure washer who has not read the Owner's Manual and been instructed on safe use practices.

Safety equipment/controls. Always operate with all safety covers, guards, and barriers in place and in good working order, and all controls properly adjusted for safe operation.

Moving parts. Keep hands, feet, hair and apparel away from moving parts. Air vents may cover moving parts and should be avoided as well. Never remove any guards while the unit is operating.

Ear Protection. Hearing can be damaged from prolonged, close-range exposure to the type of noise produced by this pressure washer. The use of ear plugs or other hearing protection device is recommended for persons working within 15-20 feet of the running pressure washer for an extended period of time.

Eye Protection. Wear ANSI/OSHA required "Z87.1" safety glasses when operating or servicing the pressure washer. Pressurized spray from this unit can cause severe injury to the eyes. Small objects can become airborne as the spray contacts them.



LIFAN POWER USA

SAFE OPERATION



NOTE: Before starting the pressure washer, review the following general safety rules for operation:

CONDITIONS FOR USE

Know how to stop. Be thoroughly familiar with proper use of the equipment and all controls and connections. Know how to stop the pressure washer and depressurize system quickly if needed.

Instruct all operators. The pressure washer's owner must instruct all operators and potential renters in safe set-up and operation. Do not allow anyone to operate the pressure washer who has not read the Owner's Manual and been instructed on its safe use.

Adult control only. Only trained adults should set up and operate the pressure washer. Do not let children operate. Pressure washers can generate forces greater than children can control and require judgment beyond what can be expected of children.

Under the influence. Never operate, or let anyone else operate, the pressure washer while fatigued or under the influence of alcohol, drugs, or medication.

Safety equipment / controls in place. Do not operate the pressure washer unless all safety covers, guards, and barriers are in place and in good working order, and all controls are properly adjusted for safe operation.

Damaged. Do not operate the pressure washer with damaged, missing, or broken parts. Never attempt to repair a high pressure hose or component. Always replace it with a part that is rated at or above the pressure rating of the machine.

Modifications. Do not modify the pressure washer in any way or deactivate any safety device. Do not change or add to fuel tank, fuel lines, or exhaust system. Modifications can result in hazards related to carbon monoxide poisoning, fuel leaks, fire, explosion or other serious safety hazards, and will also void the warranty.



LIFAN POWER USA

SAFE OPERATION

DURING USE

Stay alert. Watch what you are doing at all times.

Clear work area. Clear the work area of all bystanders.

Keep children and pets away.

Keep spray away from electrical wiring. Spray contact with electrical wiring will likely result in severe electrical shock or electrocution.

Hot exhaust/parts. Stay clear of engine exhaust. Never touch hot engine muffler, or other hot surfaces. All are very hot and will burn you.

Never pull by hose. Do not move this machine by pulling on the hose. Hose or connections could fail and result in catastrophic high pressure release of fluid as well as hose whipping.

Avoid sharp objects. Keep hose away from sharp objects. Bursting hoses may cause injury.

No load bearing. Do not use the pump to support other items of equipment that impose unacceptable loads on the pump. Do not attempt to use this machine as a prop.

Lock trigger safety latch when not spraying. Spray gun is equipped with a built-in trigger safety latch to guard against accidental trigger release. Rotate safety latch to the locked position when not spraying.

Do not run Pressure Washer without proper inlet water supply to high pressure pump and for more than 1 minute without depressing trigger on gun to circulate water to avoid damaging pump.



LIFAN POWER USA

SAFE OPERATION

Leaving unattended. Always turn off the pressure washer and relieve system pressure before leaving the sprayer unattended.

PROMPT EMERGENCY RESPONSE

Seek medical aid for suspected injection injury. If injured by high-pressure fluid, no matter how small the wound is, see a doctor at once. A typical injection injury may be a small puncture wound that does not look serious. However, severe infection or reaction can result if proper medical treatment is not administered immediately by a doctor who is familiar with injection injuries.

Seek medical aid for suspected carbon monoxide poisoning. The running engine gives off carbon monoxide, a poisonous gas that can kill you. If you start to feel sick, dizzy, or weak while using the pressure washer, shut off the engine and get to fresh air **RIGHT AWAY**. See a doctor. You may have carbon monoxide poisoning.



WARNING: Personal Protective Gear

Use personal protective gear to prevent:

- Eye and skin injection injury from high pressure spray
- Eye injury from flying debris

1. Wear waterproof gloves, safety glasses with side and top protection, face protection, and protective clothing when operating the machine. If spraying pressure washer specific chemicals, wear a respirator mask to avoid inhalation of vapors if directed on the chemical label.
2. Wear non-slip, protective footwear. Use of pressure washer can create puddles and slippery surfaces. Wear footwear capable of maintaining a good grip on wet surfaces.
3. Wear footwear capable of maintaining a good grip on wet surfaces.



LIFAN POWER USA

LIMITED WARRANTY POLICY

This warranty is limited to the following Lifan Power and Storm Series products that are distributed by the EquipSource LLC, d/b/a LIFAN POWER USA, located at 2205 Industrial Park Road, Van Buren, AR 72956. Effective date is 4/20/2010.

LENGTH OF WARRANTY

PRODUCTS COVERED	Residential Use**			Commercial/Rental**
	1st Year	2nd Year	3rd Year	Warranty not to exceed 300 hrs. or terms listed below.
Walk Behind Mowers	Full unit parts and labor	Full unit parts only	Engine: parts only	Full unit: 3 months parts and labor
Water Pumps	Full unit parts and labor	Full unit parts only	Engine: parts only	Full unit: 12 months parts and labor
Generators/Inverter Generators	Full unit parts and labor	Full unit parts only	Engine: parts only	Full unit: 12 months parts and labor
Pressure Washer Engines	Full unit parts and labor	Full unit parts only	Engine: parts only	Full unit: 12 months parts and labor
Pressure Washer Pumps*	Full unit parts and labor	NA	NA	Full unit: 12 months parts and labor
Gasoline Engines	Full unit parts and labor	Full unit parts only	Engine: parts only	Full unit: 12 months parts and labor
Gasoline Powered Welders	Full unit parts and labor	Full unit parts only	Engine: parts only	Full unit: 6 months parts and labor

*All Lifan Pressure Pro™ and Storm Series Pressure Storm™ pressure washers are equipped with Annovi Reverberi™ high pressure water pumps which are covered by the manufacturer's 1 year limited warranty. Go to www.lifanpowerusa.com for details.

** Residential Use is defined as items that are for personal use.

*** Commercial/Rental use is defined as any usage for income producing or other business related uses.

In order to qualify for the limited warranty the product(s) must be purchased in North America from an authorized EquipSource, LLC d/b/a Lifan Power USA dealer or a dealer authorized by EquipSource to sell Lifan products. This warranty is non-transferable and applies only to the original purchaser. The supplied "Warranty Registration Card" must be completed and on file with American Warranty Service (at the supplied address), at the time that any warranty claim is made. The "Warranty Registration Card" must be submitted with a receipt of purchase which clearly states the date of purchase and where the purchase was made.

During the warranty period (stated above) Equipsource, LLC and/or American Warranty Service will repair or replace, at its' option, any part that is proven to be defective in material or workmanship under normal usage. Repairs and/or replacement will be made without charge for parts or labor. All parts found to be defective must be returned to EquipSource or American Warranty Service at our direction. Upon reception of the parts a judgment as to the validity of the warranty claim will be determined. All parts replaced under warranty or any replacement of the complete unit will be considered part of the original product and replacement of any product, and any warranty on those parts or replacement unit will coincide with the original warranty.

To obtain Warranty Service, call our Customer Service Hotline at 1-866-471-7464 and press 2 for Warranty Service at which time you will be transferred to the technicians at American Warranty Service. In lieu of this you may call directly to American Warranty Service at 866-926-4313 to be directly connected to a repair specialist. If your issue cannot be resolved through consultation with our customer service representatives, you will be directed to an Independent Service Center of your choice nearest your location. Any manufacture's Defects of your product will be repaired or replaced at no charge to you per our commitment. If the issue with your unit is not a Manufacture's Defect, you will be advised to make payment to the Service Center upon diagnosis of repairs which are not covered under the Manufacturer's Warranty Policy. In this case the end user is responsible for all shipping and handling charges associated with the exchange and as stated above the warranty will coincide with the date of the original purchased unit.



LIFAN POWER USA

LIMITED WARRANTY POLICY

This warranty is not valid for products or parts affected or damaged by accident, collision, normal wear, fuel contamination, abuse, neglect, misuse, alteration and/or unsuitable use or unauthorized parts replacement. Mower decks and blades are specifically not warranted for impact or abrasive damage. Warranty becomes void if the customer fails to install, maintain, and/or operate the product in accordance with the instructions and recommended actions of Lifan set forth in the owner's manual. EquipSource, LLC disclaims any responsibility for time loss or loss of usage of the product, transportation, commercial loss, or any other incidental or consequential damage. Prior to any warranty service an approval code must be issued to the service center in order for the warranty claim to be valid. Any implied warranties are limited to the duration of this written limited warranty. This warranty gives you specific legal rights, and you may also have other rights, which may vary from state to state.

OWNER'S RESPONSIBILITY

To ensure trouble free warranty coverage it is important that you register your Lifan generator by phone at 1-866-471-7464, or by filling out and returning to Lifan Power USA the warranty registration card supplied with your generator.

REGISTERING YOUR PRODUCT

This confirms your warranty coverage and provides a direct link between you and Lifan Power USA if we find it necessary to contact you. Your receipt for purchase including date, model and serial number must be maintained and registered to receive service from an Authorized Service Dealer for warranty service. Proof of purchase rests solely with you, the original purchaser. You must demonstrate reasonable care and use, and follow preventive maintenance, storage, fuel and oil usage as prescribed in the operator's manual for your Lifan Power unit. For the warranty assistance from a Lifan Authorized Service Dealer nearest to you, call Lifan's automated phone at 1-866-471-4764 Option 2. Should you require assistance or have questions concerning Lifan Power USA Warranty Statement, you can contact us through the web at www.lifanpowerusa.com or call toll free 1-866-471-7464.

EXCLUSIONS

- Lifan Power Equipment that utilize non-Lifan replacement parts.
- Failure to perform "Periodic Maintenance" as required and specified in the supplied "Owner's Manual."
- Costs of normal maintenance and adjustments.
- Failures caused by any contaminated fuels, oils, or lack of proper oil levels.
- Repairs or diagnostics performed by individuals other than Lifan authorized dealers not authorized in writing by Lifan.
- Failures due to normal wear and tear, accident, misuse, abuse, negligence or improper use.
- As with all mechanical devices, the Lifan engines need periodic part(s) service and replacement to perform as designed. This warranty will not cover repair when normal use has exhausted the life of a part(s) or engine.
- Failures caused by any external cause or act of God, including but not limited to, collision, theft, vandalism, riot, war, fire, freezing, lightning, earth-quake, windstorm, hail, water, flood, tornado, or hurricane or any occurrence outside of normal use and activity.
- Damage related to any animal infestation to include rodent and/or insect infestation.
- Products that are modified or altered in a manner not authorized in writing by Lifan.
- Any incidental, consequential or indirect damages caused by defects in materials or workmanship, or any delay in repair or replacement of the defective part(s).
- Failure due to misapplication.
- Telephone, cellular phone, facsimile, internet access, or other communication expenses.
- Expenses related to "customer instruction" or troubleshooting where no manufacturing defect is found.
- Overnight freight or special shipping costs for replacement part(s).
- Overtime, holiday or emergency labor.
- Starting batteries, fuses, light bulbs and engine fluids.
- **SPECIAL RESTRICTION ON ALL RESIDENTIAL GRADE EQUIPMENT:** Any residential grade unit used in a commercial application falls under a 60-day limited warranty.



LIFAN POWER USA

LIMITED WARRANTY POLICY

DISCLAIMER OF IMPLIED WARRANTIES

This limited warranty is in lieu of all other expressed or implied warranties, including any warranty of the unit's fitness for any particular use and any implied warranty of MERCHANTABILITY otherwise applicable to Lifan Power Equipment and its affiliated companies shall not be liable for any special, incidental or consequential damage, including lost profits. There are no warranties extended other than as provided herein. This limited warranty may be modified only by Lifan Power USA. Any implied warranties allowed by law shall be limited in duration to the terms of the express warranty provided herein. Some states do not allow limitations on how long an implied warranty lasts, so the above limitation may not apply to you. Some states do not allow the exclusion or limitation of incidental or consequential damages, so the above limitation may not apply to you. This warranty gives you specific legal rights. You also have other rights from state to state. Lifan's ONLY LIABILITY SHALL BE THE REPAIR OR REPLACEMENT AS STATED ABOVE. IN NO EVENT SHALL Lifan BE LIABLE FOR ANY INCIDENTAL OR CONSEQUENTIAL DAMAGES, EVEN IF SUCH DAMAGES ARE A DIRECT RESULT OF Lifan's NEGLIGENCE. Some states do not allow the exclusion or limitation of incidental or consequential damages, so the above limitation may not apply to you. This warranty gives you specific legal rights and you may also have other rights from state to state.

GOVERNING LAW/ CONSENT TO JURISDICTION AND FORUM SELECTION

The laws of the State of Arkansas shall govern the rights and duties of the parties under this agreement and jurisdiction and venue is fixed in Crawford County, Arkansas. The buyer/owner hereby waives any right it may have to assert the doctrine of forum non conveniens or similar doctrine or to object to venue with respect to any proceeding brought in accordance with this paragraph, and stipulates that the State and Federal courts located in the County of Crawford, State of Arkansas shall have in person jurisdiction and venue over each of them for the purpose of litigating any dispute, controversy, or proceeding arising out of or related to the sale, manufacture or warranty of products with EquipSource, LLC.

OWNER'S WARRANTY RESPONSIBILITIES

As the outdoor equipment owner, you are responsible for performance of the required maintenance listed in your owner's manual. EquipSource, LLC d/b/a Lifan Power USA recommends that you retain all receipts covering maintenance on your outdoor equipment. Lifan Power USA will not deny your warranty coverage based solely on your lack of receipts for service however, the condition of the equipment upon arrival at the service center will determine the warrantable nature of the product.

As the outdoor equipment owner, you should however be aware that Lifan Power USA may deny your warranty coverage if your outdoor equipment or a part has failed due to abuse, neglect, or improper maintenance or unapproved modifications.

If you have any questions regarding your warranty rights and responsibilities, you should contact Lifan Power USA or American Warranty Service Representative at 1-866-471-7464 Option 2 Warranty and Service or at the following address Lifan Power USA, 2205 Industrial Park Road, Van Buren, AR 72956 or by contacting us through www.lifanpowerusa.com.

This warranty specifically excludes the use of any Lifan Power Equipment or Storm Series power equipment as the "Sole Source of Power" for "off the power grid applications" and this warranty will become null and void for units used for this purpose and manner. This warranty specifically excludes the use of any Lifan Power Equipment or Storm Series power equipment for the purpose of powering Life Support devices, Life Support appliances, Medical devices, and/or Medical appliances.

EquipSource, LLC will not be held responsible for any damage due to the use of any Lifan or Storm Series power equipment for these purposes.



LIFAN POWER USA

APPENDIX



RQV

VERSION

D 3400rpm

ø 3/4"

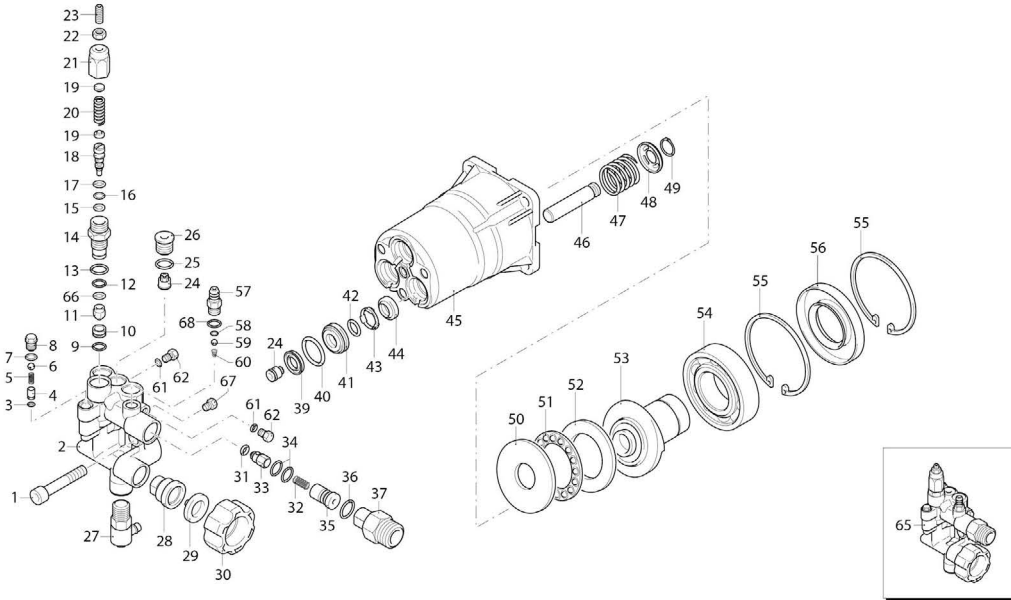

UN004048-FS

KIT RICAMBI / PART KITS

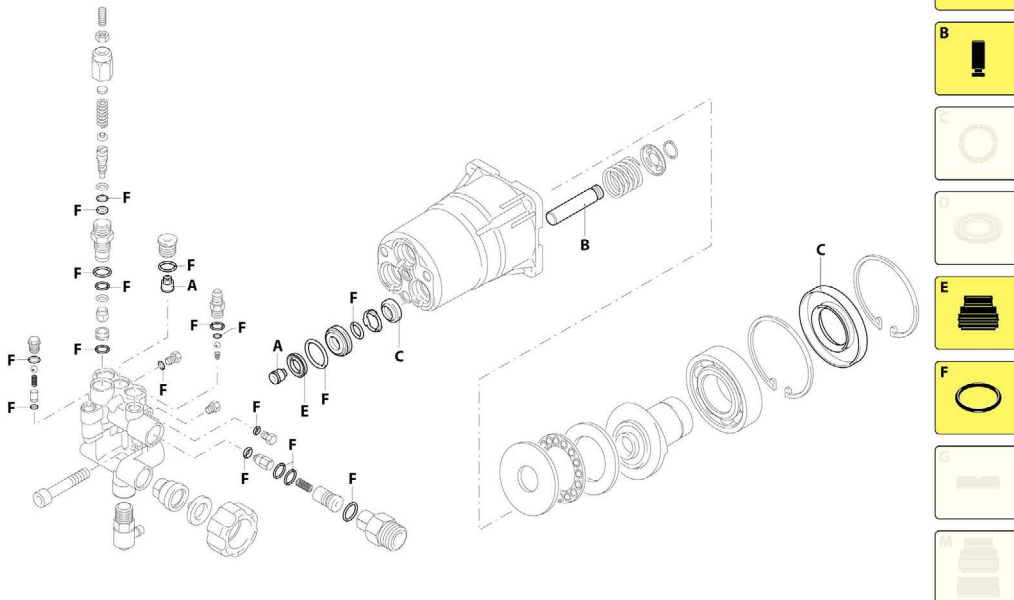

UN004049-FS

(372860)



LIFAN POWER USA

372 Series										RQV 3400 rpm D version ø 3/4"					AR
2.5 G30															
Pos.	Cod.	Denominazione	Description	Qt	Note	Pos.	Cod.	Denominazione	Description	Qt	Note				
1	380410	Vite TCEI M8x40	Screw	3	C=20Nm	44	1683500	Tenuta olio	Oil seal	3					
2	3720770	Testa ottone	Head	1		45	3720790	Corpo pompa	Pump body	1					
3	3720750	Guarnizione OR Ø 4x1	O-ring	1		46	3720340	Pistone Ø 12	Piston	3					
4	3720740	Sede	Seat	1		47	3720380	Molla	Spring	3					
5	3720760	Molla	Spring	1		48	3720360	Fermo	Lock	3					
6	1250280	Sfera	Ball	2		49	3720390	Anello	Ring	3					
7	1682800	Guarnizione OR Ø 6x1,5	O-ring	1		50	1980130	Ralla	Fifth wheel	1					
8	3720730	Tappo	Plug	1	C=4Nm	51	1980250	Ralla	Fifth wheel	1					
9	1470210	Guarnizione OR Ø 9x1	O-ring	1		52	1980240	Ralla	Fifth wheel	1					
10	3720500	Sede	Seat	1		53	2841190	Piattello 13" marcato 3	Wobble plate	1					
11	3720520	Otturatore	Shutter	1	C=3Nm	54	161060	Cuscinetto	Bearing	1					
12	3720560	Guarnizione OR Ø 4,5x1,5	O-ring	1		55	161050	Anello seeger Ø1 72	Ring	2					
13	394280	Guarnizione OR Ø 12,42x1,78	O-ring	1		56	2841050	Anello tenuta	Ring	1					
14	3720620	Guida pistone	Piston guide	1	C=20Nm	57	3700240	Portagomma Ø 8	Hose tail	1	C=4Nm				
15	3720570	Guarnizione OR Ø 9x1,5	O-ring	1		58	480480	Guarnizione OR Ø 4,48x1,78	O-ring	1					
16	660190	Guarnizione OR Ø 6,07x1,78	O-ring	1		60	1560520	Molla	Spring	1					
17	3720600	Anello antiestrusione	Ring	1		61	3201760	Guarnizione OR Ø 4x1,5	O-ring	2	C=4Nm				
18	3720540	Otturatore	Shutter	1		62	3720720	Tappo	Plug	2					
19	3720660	Piattello	Wobble plate	2		65	3729200	Premontaggio testa	Head assembly	1					
20	3720640	Molla	Spring	1		66	3720580	Anello antiestrusione	Ring	1					
21	3720681	Guida	Guide	1		67	3720830	Tappo gomma	Plug	1					
22	1060120	Dado M6	Nut	1		68	3700250	Guarnizione OR Ø 8x1,1	O-ring	1	80 ShA				
23	392840	Vite M6x16	Screw	1											
24	2849053	Valvola completa	Complete valve	6											
25	770140	Guarnizione OR Ø 11,11x1,78	O-ring	3											
26	3720441	Tappo	Plug	3	C=20Nm										
27	2761380	Valvola	Valve	1	C=16Nm										
28	2841230	Raccordo alluminio	Fitting	1	C=25Nm										
29	1266330	Filtro	Filter	1											
30	2841220	Raccordo 3/4"NH	Fitting	1											
31	1460431	Guarnizione OR Ø 4x2,5	O-ring	1											
32	3700210	Molla	Spring	1											
33	3700220	Valvola	Valve	1											
34	800560	Guarnizione OR Ø 8,73x1,78	O-ring	2	✘										
35	3700200	Iniettore	Injector	1											
36	2840890	Guarnizione OR Ø 14x2	O-ring	2											
37	2841120	Raccordo	Fitting	1	C=25Nm										
39	2200141	Tenuta acqua	Water seal	3											
40	770590	Guarnizione OR Ø 21,95x1,78	O-ring	3	✘										
41	3720410	Boccola	Bushing	3											
42	3660340	Guarnizione OR Ø 12x2	O-ring	3	✘										
43	3720400	Distanziale	Spacer	3											

KIT RICAMBI - PART KITS						SIMBOLOGIA - SYMBOLS							
A=KIT 42955 valvole valves		B=KIT 42956 ø 12 pistoni pistons		C=KIT 42960 tenute olio oil seals		E=KIT 42958 ø 12 tenute acqua water seals							
Pos.	Q.ty	Pos.	Q.ty	Pos.	Q.ty	Pos.	Q.ty						
24	6	46	3	44	3	39	3						
				56	1								
F=KIT 42959 OR O-Rings													
Pos.	Q.ty	Pos.	Q.ty	Pos.	Q.ty	Pos.	Q.ty						
3	1	25	3	61	2								
7	1	31	1	68	1								
9	1	34	2										
12	1	36	2										
13	1	40	3										
15	1	42	3										
16	1	58	1										

Olio - Oil			
Tipo / Type	Quantità / Quantity		
SAE 75W90	0,065 Kg		

C Tolleranza coppia di serraggio 0-10% / Tightening torque tolerance 0-10%

✘ Avvitare con Loxeal 55-14 / Screw with Loxeal 55-14

✘ Lubrificare con grasso Molykote PG54 / Lubricate with grease Molykote PG54

☐ Avvitare con Loxeal 83-55 / Screw with Loxeal 83-55



LIFAN POWER USA

ELECTRIC START UNITS ONLY

ELECTRIC DIAGRAM (for electric-start type)

Bl	Black	Gr	Grey
Y	Yellow	R	Red
W	White	G	Green

	IC	B	ST	BAT
OFF	○	○		
ON				
START			○	

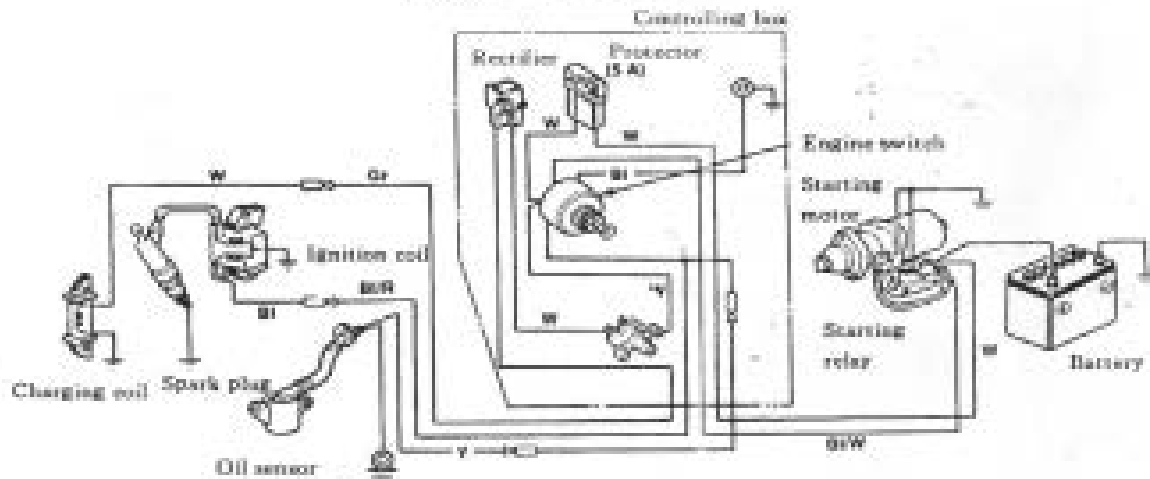

ELECTRIC DIAGRAM

Bl	Black
Y	Yellow
G	Green

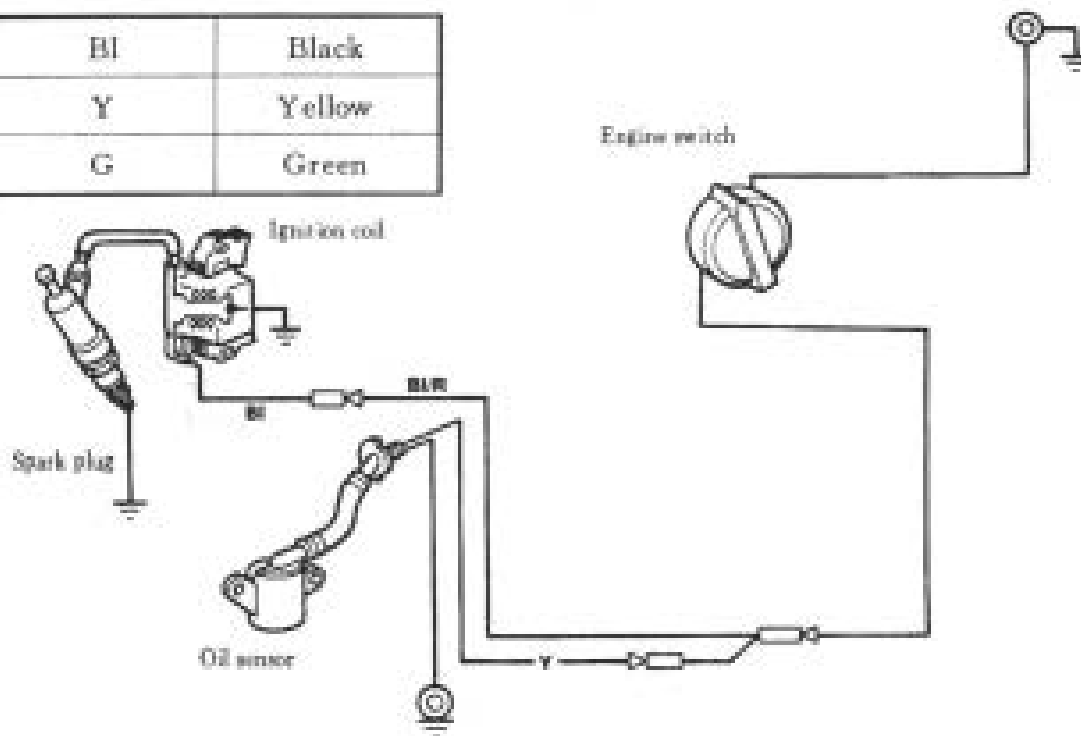



LIFAN POWER USA

BATTERY SPECIFICATIONS (Electric Start (E) Models Only)

The Battery is NOT included with your Energy Storm Generator. These units require an Acid Cell Battery. This battery is used in many applications, such as lawnmowers, ATV's, motorcycles, etc. and can be found at many retailers and dealers including where you purchased this Power Equipment Product. Use the "Battery Specifications" chart below to attain the specifications of the necessary battery. Or, use the "Cross Reference Models" chart below to match up with the manufacturer's model number with the brand battery available at your local retailer.

BATTERY SPECIFICATIONS				
Generator Model	Length (inch)	Width (inch)	Amp (hrs)	DC Voltage (Volts)
LFQ2565	5.25 in	3 in	10	12V
LFQ2865	5.3125 in	3.1875 in	12	12V
LFQ3370	5.3125 in	3.1875 in	12	12V

CROSS REFERENCE MODELS		
Generator Model	Manufacturer	Model Number
LFQ2565	Super Start®	CB9B
LFQ2865	Excide®	12N12A-4A-1
LFQ3370	Excide®	12N12A-4A-1

Note: (-CA) or (E) Models have same Battery Specifications

	<h3>Warning</h3>
Follow all the battery manufactures' warnings for proper installing of your battery in order to prevent damage to personnel or equipment.	

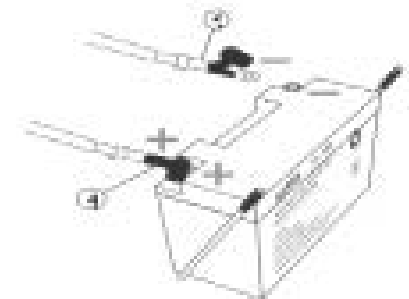

1. Battery leads consist of a Red (hot) lead that connects to the (+) battery post and is connected to the (+) terminal on the starter solenoid and a Black lead which is connected to the (-) negative battery terminal and the frame mounting bolt.
2. Connect the Red (hot) terminal to the battery.
3. Connect the Black (negative) terminal to the battery.

Lifan Power USA is proud to offer its extensive line of Lifan power equipment.

Lifan Power USA is the sole distributor for Lifan power equipment in the United States. Lifan's unmatched investment in research & development ensures quality engines, generators, pressure washers, and water pumps at an extraordinary value. Lifan continues to be an innovator and presently holds over 4,000 international patents. Product performance has earned Lifan the reputation of dependability and value in all their international markets.

Lifan has been manufacturing and selling innovative and value driven products worldwide for over 20 years. Lifan is distributed in over 100 countries. Lifan is one of the largest publicly traded companies in China with sales over one billion dollars annually and 14,000 employees.

LIFAN POWER USA

As the largest engine manufacturer in China, Lifan builds more than five million small engines each year. This worldwide presence has been made possible by producing equipment that is durable, reliable, and rugged for any market.

Lifan Power USA prides itself in standing behind all Lifan products with our comprehensive warranty policy. Lifan Power USA continues to offer the highest level of service and support in the industry. With proven performance and unmatched value, Lifan power equipment will always keep you running.

All information in this publication is based on the latest product information available at the time of approval for printing. EquipSource, LLC reserves the right to make changes at any time without notice and without incurring any obligation. The copyright of this document belongs to EquipSource, LLC. No part of this publication may be reproduced without the written permission of EquipSource, LLC.

**Made in PRC and
Distributed by Lifan Power USA
2205 Industrial Park Road
Van Buren, AR 72956
(866) 471-7464**