



APW5101

2000PSI PRESSURE WASHER

Owner's Manual 2000PSI PRESSURE WASHER



HAVE QUESTIONS OR NEED SERVICE	DES QUESTIONS BESOIN D'UNE RÉPARATION	PREGUNTAS O NECESITA SERVICIO
DO NOT RETURN TO STORE	NE PAS RETOURNER AU MAGASIN	POR FAVOR NO REGRESE A TIENDA
888-896-6881	888-896-6881	888-896-6881

SAFETY GUIDELINES

Thank you for purchasing a Pressure Washer. Whether you are doing light cleaning at home or are needing power to do the tough jobs, pressure washers are built to give you the power you need. Your pressure washer will serve you in the future. Following proper break-in procedures, by using recommended set-up and operating procedures, and performing preventive maintenance as specified in this and the accompanying engine manual.

Most important is the safety of you and those around you. Remember that while the pressure washer gives you the power you need to complete your job, safety rules should always be followed.

Thank you for selecting our product.

Safety Symbols

The following symbols are used throughout this manual. Follow listed instructions to ensure your safety.

⚠ DANGER

Indicates an imminently hazardous situation which, if not avoided, will result in death or serious injury.

⚠ WARNING

Indicates an imminently hazardous situation which, if not avoided, will result in death or serious injury.

⚠ CAUTION

Indicates a potentially hazardous situation exists, which if not avoided, may result in minor or moderate injury or product damage.

Note: Indicates operation or maintenance information helpful to improve performance or operation.

The following Safety Precautions apply whenever using storing or servicing Pressure Washers or their engines to reduce the possibility of personal injury.

Overlooking or ignoring these precautions can lead to personal injury or product damage.

⚠ WARNING

- Read this manual carefully. Know your equipment. Consider applications, potential hazards and limitations for your unit.
- This equipment is designed for specific applications. Do not modify or use for any application other than which it is designed.
- Store the pressure washer in a well ventilated area with the fuel tank empty. Fuel should not be stored near the pressure washer.
- Never operate under these conditions:
 - a. A noticeable change in engine speed.
 - b. A noticeable loss of pressure.
 - c. The engine misfires.
 - d. Smoke or flames are present.
 - e. Enclosed compartment.
 - f. Excessive vibration.
 - g. Rain or inclement weather.
- Water spray must never be directed towards any electric wiring or directly towards the pressure washer.
- Do not allow the hose to come in contact with the hot muffler.
- Equipment must be placed on a firm, supporting surface.
- Remove the spark plug or cable from the spark plug to prevent accidental starting, when not in use, or prior to detaching the high pressure hose.
- Keep the pressure washer clean and free of oil, mud and other foreign matter.
- Do not wear loose clothing, jewelry, or anything that may be caught in the engine.
- Never direct spray at people or animals.
- Never allow children to operate pressure washer at any time.
- Use both hands to control the wand.

GENERAL PRECAUTIONS

WARNING



- Do not touch the nozzle or water spray while operating.
- Wear safety goggles while operating.
- Only approved hoses and nozzles should be used.
- The trigger gun must not be jammed in position during operation.
- Never tie knots or kink the high pressure hose.
- All hose connections must be properly sealed.
- Prior to starting the pressure washer in cold weather, be sure ice has not formed in any part of the equipment.
- Use only recommended chemicals.
- Outdoor use only.
- Place the pressure washer away from cleaning site during operation.
- To prevent accidental discharge, the spray gun should be secured by locking trigger when not in use.
- Do not run the pressure washer for more than five minutes without depressing the trigger or damage to the pump may result.
- Check the fuel system periodically for leaks or signs of deterioration such as chafed or spongy hose, loose or missing clamps, or damaged tank or cap. All defects should be corrected before operation.
- Do not touch hot muffler.
- Service, operate and refuel under the following conditions:
 - a. Good ventilation.
 - b. Refuel the pressure washer in a well lighted area.
 - c. Avoid fuel spills and never refuel while the pressure washer is operating.
 - d. Avoid an ignition source when refueling.
 - e. Use lead free fuel with a minimum of 85 octane.
- Do not smoke near the pressure washer.
- Do not use damaged high pressure hoses.
- Do not operate under 40° Fahrenheit.

SAFETY FEATURES

THERMAL RELIEF VALVE

A thermal relief valve is provided to protect the pump from overheating if the spray gun is closed for an extended length of time or the nozzle becomes plugged. However, it is intended to be used as a backup system and every effort should be made to not permit the pump to heat up.

We recommend turning the pressure washer off if it will not be used for more than five minutes. This saves wear on the unit, reduces fuel consumption and extends the life of the pump by avoiding heat.

SAFETY LOCK OFF LATCH

To prevent accidental discharge of high pressure water, the safety latch on the trigger should be engaged whenever the pressure washer is not in use.

LOW-OIL SHUTDOWN

Some engines are equipped with low-oil shutdown. If the engine oil level becomes lower than required, the pressure washer will automatically shut off. (Refer to the engine manual for this feature). This protects your pressure washer engine from operating without proper lubrication.

If the pressure washer engine shuts off and the oil level is according to specification, check to see if the pressure washer is sitting at an angle that forces oil to shift. Place on an even surface to correct this. If the engine fails to start, the oil level may not be sufficient to deactivate low oil level switch. Be sure the pump is completely full of oil.

CAUTION



The pump will overheat and may be damaged, or cause damage if allowed to circulate more than five minutes.

BEFORE OPERATION

NOTE: The engine and pump on your pressure washer will often have improved performance after a break-in period of several hours.

PRE-START PREPARATION

Before starting the pressure washer, check for loose or missing parts and for any damage which may have occurred during shipment.

ASSEMBLY & START-UP

HOSE AND GUN ASSEMBLY

NOTE: Align threaded connections carefully to prevent damaging threads during assembly. Tighten connections securely to prevent leaks during operation.

Attach the hose to the inlet of the trigger gun.

LUBRICATION

DO NOT attempt to start the pressure washer engine without filling the engine crank case with the proper amount and type of oil. (See the accompanying engine manual for this information.) Your pressure washer engine has been shipped from the factory without oil in the engine crankcase.

Operating the unit without oil will ruin the engine.

The pump has been shipped with oil. Before operating the pressure washer check the oil level of the pump to make sure the oil level is to pump's manufacturers required level. Use oil that is recommended from the pump's manufacturer. DO NOT OVERFILL!

FUEL

Fill the tank with clean, fresh unleaded automotive gasoline. Regular grade gasoline may be used provided a high octane rating is obtained (at least 85 pump octane).

WARNING



Gasoline is very dangerous. Serious injury may result from fire caused by gasoline engine contacting hot surfaces.

OPERATING CONNECTIONS

HIGH PRESSURE HOSE

Attach the high pressure hose to the pressure washer by pulling back the collar on the quick connect coupling on the hose and pushing it over the coupling half on the pressure washer outlet.

NOTE: DO NOT use a high pressure hose from another manufacturer.

WATER CONNECTION

Before connecting to unit, run water through the garden hose (not supplied) to flush out any foreign matter.

Attach garden hose to the pressure washer water inlet.

NOTE: The water supply must provide a minimum of 4 g.p.m. at 20p.s.i. or the pump may be damaged.

OPERATING INSTRUCTIONS

START-UP PROCEDURE

1. Make sure water supply is connected and turned on.
2. Release gun safety if locked.
3. To allow air to escape from the hose, squeeze trigger on the gun until there is a steady flow of water coming from the nozzle.
4. Remove any dirt or foreign matter from the gun outlet and the male connector of the wand.
5. Insert the nozzle wand into the gun wand and tighten the twistfast fitting securely by hand.

WARNING



If the wand is not securely locked into place, it could be ejected under high pressure when operating the gun, possibly causing injury or damage.

STARTING THE ENGINE

1. Check oil and fuel level.
2. Adjust choke prime as necessary.
3. Set the engine switch to the "ON" position.
4. Squeeze trigger on pressure washer to release pressure while pulling on the engine starter rope with a fast steady pull. Pressure may otherwise build up making starting the unit difficult.
5. As the engine warms up, re-adjust the choke.

CHEMICAL INJECTION

CAUTION

This pressure washer is intended for use only with liquid car wash detergents, developed specifically for pressure washer and with mild soaps. Only use chemicals compatible with the aluminum and brass parts of the pressure washer. Powdered soaps may clog the injection system. Always use chemicals according to the manufacturer directions. We assume no responsibility for any damages caused by chemicals injected through this pressure washer.

1. Attach injection tube assembly to the siphon injector on the pump.
2. Open a container of chemicals and place next to the unit near the injection tube.
3. Visually inspect strainer at the end of the injection tube to verify that it is not clogged.
4. Insert the injection tube into the container all the way to the bottom.

MAINTENANCE

- Remove the high pressure nozzle from the wand and install the black injection nozzle. The solution will automatically mix with the water and discharge through the nozzle.

NOTE: For certain models, if the engine throttle is not in the fast position, the injection of the solution may be decreased or stopped.

CLEANING TECHNIQUES

Cleaning Techniques

When cleaning with the pressure washer, many cleaning tasks can be solved with water alone, but for most tasks, it is advantageous to use a detergent also. A detergent ensures a quick soaking of the dirt allowing the high pressure water to penetrate and remove the dirt more effectively.

APPLICATION OF SOAP OR DEGREASER

- Apply the solution to a DRY work surface. On a vertical surface, apply horizontally from side to side starting from the bottom to avoid streaking.

NOTE: Wetting the surface first is not recommended, it dilutes the detergent and reduces its cleaning effects.

Avoid working on hot surfaces or in direct sunlight to minimize the chances of the chemical damaging painted surfaces. Damage may occur to painted surface if chemical is allowed to dry on the surface. Hold nozzle far enough away from surface to prevent damage to the surface.

- Allow chemical to remain on the surface for a short time before rinsing.
- Rinse with clean water under high pressure. On a vertical surface, first rinse from the bottom up, then rinse from the top down. Hold nozzle 6 to 8 inches from the work surface at a 45° angle using the flat spray as a peeling tool rather than a scrub brush.

APPLICATION OF WAX

- Immediately after cleaning, apply wax. Place injection tube in container of wax.
- Apply the wax sparingly in an even layer. Apply to wet surfaces from bottom up for even distribution and to avoid streaking.
- Remove the suction tube from the wax bottle rinse off the surplus wax.

NOTE: IF SURPLUS WAX IS NOT REMOVED, A HAZY FINISH MAY RESULT.

- Wipe dry to reduce water spotting.

END OF OPERATION

End of Operation

When you have completed use of the chemical injection system, remove tube from container. Continue to run in low pressure position and inject clean water through the tube and injection system by placing end of tube in a container of clean water. Continue to run until it is thoroughly cleaned.

MAINTENANCE

CONNECTIONS

Connection on pressure washer hoses, gun and spray wand should be cleaned regularly and lubricated with the manufacturer's recommended grease to prevent leakage and damage to the o-rings.

NOZZLE

Clogging of the nozzle causes the pump pressure to be too high and cleaning is immediately required.



WARNING



A nozzle cleaner must only be used when the spray wand is disconnected from the gun or personal injury could be occur

- Separate the wand from the gun.
- Clear the nozzle with a small rigid piece of wire such as a paper clip.
- Flush the nozzle backwards with water.
- Reconnect the wand to the gun.

Restart the pressure washer and depress the trigger on the spray gun. If the nozzle is still plugged or partially plugged, repeat above instructions 1-4.

If the previous procedure does not clear the nozzle, replace with a new nozzle.

WATER SCREEN

The pressure washer is equipped with a water inlet screen to protect the pump. If the screen is not kept clean, it will restrict the flow of water to the pressure washer and may cause damage to the pump. Do not damage the screen while removing or cleaning screen. Any foreign particles entering the pump may damage the pump. Do not operate pressure washer without the screen in place.

Remove the screen and backflush to remove impurities from screen. Replace immediately.

MAINTENANCE

ENGINE MAINTENANCE

During the winter months, rare atmospheric conditions may develop which will cause an icing condition in the carburetor. If this develops, the engine may run rough, lose power and may stall. This temporary condition can be overcome by deflecting some of the hot air from the engine over the carburetor area.

NOTE: Refer to the engine manufacturer's manual for service and maintenance of the engine.

STORAGE

PUMP STORAGE

If you must store your pressure washer in a location where the temperature is below 32°F, you can minimize the chance of damage to your machine by utilizing the following procedure:

- Shut off water supply and relieve pressure in the spray gun by depressing the trigger. Disconnect the garden hose from the pressure washer, but leave the high pressure hose connected.
- Tip the unit on its side with the inlet connection pointing up.
- Insert a small funnel (to prevent spilling) into the inlet and pour in approximately 1/4 cut of RV antifreeze.
- Disconnect spark plug wire.
- Without connecting garden hose pull the recoil several times to circulate the antifreeze in the pump system.
- Disconnect spark plug wire.



CAUTION

Prior to restarting, thaw out any possible ice from the pressure washer hoses, spray gun and wand.

Another method of reducing risks of freeze damage is to drain your pressure washer as follows:

- Stop the pressure washer and detach supply hose and high pressure hose. Squeeze the trigger of the discharge gun to drain all water from the wand and hose.
- Restart the pressure washer and let it run briefly (about 5 seconds) until water no longer discharge from the high pressure outlet.

ENGINE STORAGE

When the pressure washer is not being operated or is being stored more than one month, follow these instructions:

- Replenish engine oil to upper level.

- Drain gasoline from fuel tank, fuel line, fuel valve and carburetor.
- Pour about one teaspoon of engine oil through the spark plug hole, pull the recoil starter slowly until you feel increased pressure which indicates the piston is on its compression stroke and leave it in that position. This closes both the intake and exhaust valves to prevent the inside of the cylinder from rusting.
- Cover the pressure washer and store in a clean, dry place that is well ventilated away from open flame or sparks.

NOTE: The use of a fuel additive, such as STA-BIL, or an equivalent, will minimize the formulation of fuel gum deposits during storage. Such an additive may be added to the gasoline in the fuel tank of the engine, or to the gasoline in a storage container.

TECHNICAL SPECIFICATION

Maximum Inlet Pressure.....	Up to 90PSI
RPM.....	3450RPM
Temperature of Pumped Fluids.....	Up to 80 F
Inlet Ports.....	(2) 1/2" BSP
Discharge Ports.....	(2) 1/2" BSP
Weight.....	9lbs.
Pump oil.....	4.7 fl.oz.
Pump oil.....	SAE 30W Nondetergent

Consult the factory for special requirements that must be met if the pump is to operate beyond one or more of the limits specified above.

2000PSI PRESSURE WASHER

TROUBLE SHOOTING

PROBLEM	PROBLEM CAUSE	CORRECTION
Engine will not start or stops while operating.	Low-oil shutdown	Fill engine with oil
	Engine switch not in "ON" position	Turn switch "ON"
	Pressure built up in the hose	Squeeze trigger while starting
Engine is overloaded	Nozzle partially blocked	Clean nozzle
	Excessive pressure	Shorten the spring coil of the reflux valve
Pressure increases when gun is closed	Bypass valve blocking	Clean the bypass valve
Engine running but pumps not building maximum pressure or has irregular pressure	Faucet closed	Open faucet
	Unit has been stored in freezing temperatures.	Thaw out unit completely including hose, gun and wand.
	Inadequate water supply	Provide a minimum of 4 gpm at 20psi
	Water inlet screen clogged	Clean screen
	Kink in garden hose	Straighten garden hose
	Wand nozzle worn or damaged	Replace nozzle
	Air in pump	Let it run with gun open and wand removed until steady stream of water is released.
	Adjustable pressure knob not set to maximum position	Set to maximum position
	Suction or discharge valves clogged or worn out	Clean the suction or discharge valves
	Bypass valve not operating effectively	Clean the bypass valve
No intake of chemicals	Injection tube not securely inserted into unit	Push firmly into injector
	Tube cracked or split	Replace tube
	Wrong nozzle	Switch to low pressure nozzle
	Injector turned off	Turn collar counter clockwise
	The axle of the inner aperture of the three-way cock is different	Use a three-way cock with the imbibition function
	Injection tube strainer clogged	Clean strainer
	Nozzle blocked	Clean nozzle
	Dried chemicals injector	Dissolve by running warm water
Trigger will not move	Gun safety lock engaged	Release safety lock
Water in crankcase	High humidity	Change oil more frequently
	Worn seals	Change the oil seals
Noisy operation	Worn bearings	Change the bearing
	Air mixed with water	Check inlet lines for restrictions and/or proper sizing
Rough/pulsating operating with pressure drop	Inlet restriction	Check system for stoppages, air leaks, correctly sized inlet plumbing to pump
	Unloader	Check unloader for proper operation
	Air mixed in water	Check inlet lines for restrictions and/or proper sizing
High crankcase temperatures	Wrong grade of oil	Use recommended oil
	Improper amount of oil in crankcase	Adjust oil level to proper amount

2000PSI PRESSURE WASHER

GENERAL PARTS LIST

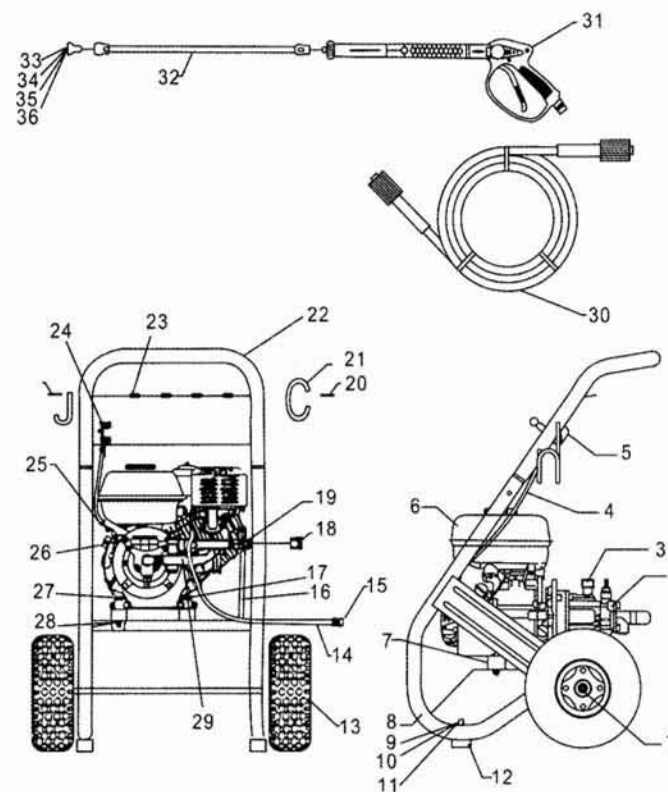

- | | |
|--|-------------------------------|
| 1 Hub cap | 19 Nut lock |
| 2 Pump assembly | 20 Screw |
| 3 Choana cover | 21 Vinyl round cap |
| 4 Accelerator wire drawing | 22 Handle |
| 5 Component of accelerator control lever | 23 Grommet |
| 6 Engine | 24 Hex Nut |
| 7 Isolator | 25 Clamp |
| 8 Carriage | 26 Oil fill pump cap |
| 9 Nut | 27 Bolt |
| 10 Plane | 28 Nut |
| 11 Bolt | 29 Whip Hose |
| 12 Rubber foot | 30 Hose |
| 13 Wheel | 31 Gun assy. |
| 14 Chemical hose | 32 Assy. Wand & quick connect |
| 15 Chemical filter | 33 Nozzle black |
| 16 Whiz bolt | 34 Nozzle red |
| 17 Hose adapter | 35 Nozzle yellow |
| 18 Nut | 36 Nozzle white |

2000PSI PRESSURE WASHER

PUMP PARTS LIST

QH-130 PUMP PARTS DRAWING

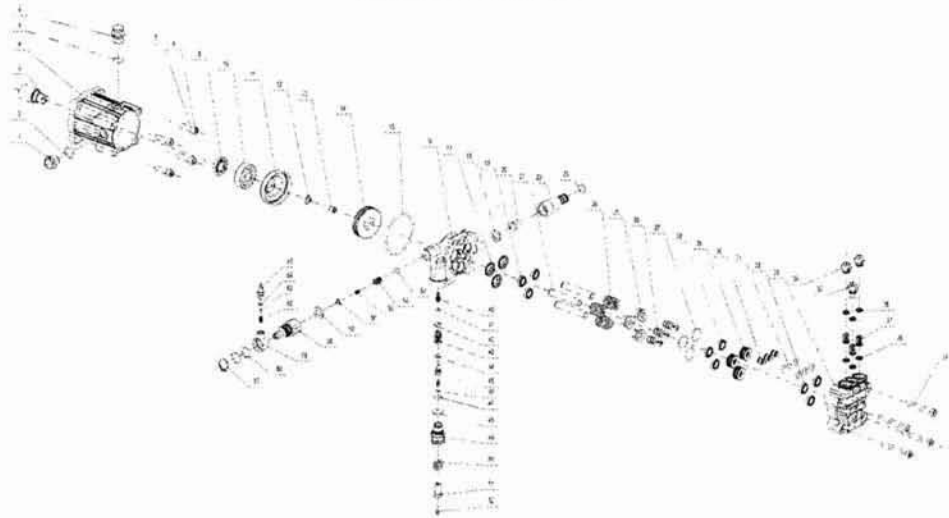

No.	Name	Qty	No.	Name	Qty	No.	Name	Qty
1	Oil level scope	1	23	O-ring	1	45	Bypass core	1
2	O-ring	1	24	Plunger spring	3	46	O-ring	1
3	Short Shaft	1	25	Tripod plunger frame	3	47	O-ring	1
4	Connection Base	1	26	Inlet valve	3	48	O-ring	1
5	O-ring	1	27	O-ring	3	49	Bypass base	1
6	Air hole screw	1	28	Water seals	3	50	Bypass valve	1
7	Washer	4	29	Water seal base	3	51	Copper nut	1
8	Hexangular bolt	4	30	Bridge pipe	3	52	screw	1
9	Frame oil seal	1	31	O-ring	6	53	O-ring	1
10	Bearing	1	32	Water seals	3	54	Outlet stopper	1
11	Eccentric Bowl	1	33	Pump Cover	1	55	Spring	1
12	Washer	1	34	Short valve cover	2	56	Clip	1
13	Hexangular bolt	1	35	Long valve cover	1	57	O-ring	1
14	Thrust bearing	1	36	O-ring	3	58	Detergent suction base	1
15	O-ring	1	37	Outlet valve	3	59	Turnable fitting	1
16	Pump body	1	38	O-ring	9	60	O-ring	2
17	Plunger wedge	3	39	Hexangular bolt	4	61	Spring clip	1
18	Washer	1	40	Outlet valve sheet	1	62	Spring	1
19	Oil seals	3	41	O-ring	1	63	Steel ball	1
20	Inlet screen	1	42	O-ring	1	64	O-ring	1
21	Plunger	3	43	Bypass plastic base	1	65	Detergent suction inlet	1
22	Inlet connector	1	44	O-ring	1			

2000PSI PRESSURE WASHER

INSTALLATION

Assembly

1. Installing Right/Left Hook
 - 1) Fix left hook on the left side of handrail by using bolt (See Fig. 1).
 - 2) Fix right hook on the right side of handrail by using bolt (See Fig. 2).

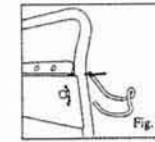
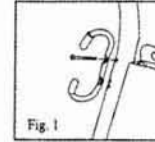

2. Installing the wheels

- 1) Hold the locating pin in the wheel set backward in horizontal level and press the locating pin into supporting tube until the click is heard, which indicates the pin clutches at the supporting tube (see Fig. 3).
- 2) Until the pin is higher than the thickness of supporting wall (see Fig. 4).

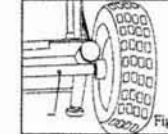
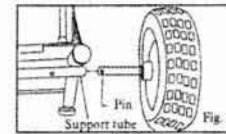

START-UP PROCEDURE

PRE-START PREPARATION

Before starting the pressure washer, check for loose or missing parts and for any damage which may have occurred during shipment.

START-UP PROCEDURE

1. Make sure water supply is connected and turned on.
2. Release gun safety if locked.
3. To allow air to escape from the hose, squeeze trigger on the gun until there is a steady flow of water coming from the nozzle.
4. Remove any dirt or foreign matter from the gun outlet and the male connector of the wand.
5. Insert the nozzle wand into the gun wand and tighten the fitting securely.
6. Place the throttle in the HI position.

STARTING THE ENGINE

1. Check oil and fuel level.
2. Adjust choke prime as necessary.
3. Set the engine switch to the "ON" position.
4. Set gas level to open
5. Squeeze trigger on pressure washer to release pressure while pulling on the engine starter with a fast steady pull. Pressure may otherwise build up making starting the unit difficult.
6. As the engine warms up, re-adjust the choke

SPRAY NOZZLE SELECTION

Following information concerning the four nozzles provided with your pressure washer. (If four nozzles are provided.)

NOTE: The force of the spray on the surface you are cleaning increases as you move closer to the surface.

0° High Pressure (Red) : The water stream discharged is very aggressive. Use with extreme caution to prevent damage to the surface being cleaned or injury to persons or animals.

15° High Pressure (Yellow): This is the nozzle used for most cleaning applications. It provides wide coverage and a powerful water stream.

45° High Pressure (White): This is the nozzle used for cleaning with a wider coverage over a larger area with a powerful water stream.

50° Low Pressure (Black): Provides lower pressure spray for a wider coverage. Used primarily when operating the chemical injector to apply chemicals.

Contents

**GAS ENGINE
OWNER'S MANUAL**

- This owner's manual contains the instruction items necessary for correct and safe use. Before operating this engine be sure to read this owner's manual to understand how to correctly operate the engine.(Incorrect operation could result in accident and injury.)
- Also be sure to read the owner's manuals of equipment used with this engine before operating this engine.
- Store this owner's manual with care so that it can be referred to at any time.

SAFE USE -----3
COMPONENT NAMES -----5
FUEL AND ENGINE OIL -----6
PRE-OPERATION ENGINE INSPECTION -----7
STARTING AND STOPPING THE ENGINE -----8
CARE OF THE ENGINE -----9
INSPECTIONS AND MAINTENANCE -----11
LONG-TERM STORAGE -----12
TROUBLE SHOOTING -----13

SAFE USE

! This mark denotes those items that are **very important for safety. Please be sure to obey them.**

! WARNING

- ! Do not allow people who do not understand this owner's manual to operate the engine.
- ! Do not run engine indoors or where the ventilation is poor.(The exhaust gas contains carbon monoxide, an odorless and harmful substance.)
- ! Do not place hands or feet near moving or rotating parts. (Be sure to cover the area around the power take off shaft and belts that link the engine with other equipment .)
- ! Do not store, spill, or use gasoline near heat or flame or equipment that uses flame or sparks, such as stoves, ovens, water heaters, etc.(An explosion could occur.)
- ! Do not add fuel indoors or where the ventilation is poor.
- ! Do not smoke when adding fuel.
- ! Do not remove the fuel tank cap or add fuel while the engine is running or hot. (Add fuel after the engine has cooled by waiting 2 or more minutes after the engine is stopped.)
- ! Do not operate the engine when gasoline has been spilt, when there is the smell of gasoline, or when there is a danger of explosion.
- ! Do not transport the engine with fuel in tank. (If fuel were to spill it could cause a fire.)
- ! Do not stop the engine by using the choke lever.
- ! Do not unreasonably adjust the engine speed.
- ! Do not check for spark with the spark plug removed.
- ! Do not operate the engine with the muffler or air cleaner removed. (Especially for the muffler, check the tightness of mounting screw, damage and leakage periodically, and if abnormality is found, repair or replace it.)
- ! Do not operate the engine with grass, leaves, or other combustible material in muffler area.
- ! Do not touch the high-voltage cord or spark plug cap.

! CAUTION

- ! Occasionally inspect the fuel system components to check for cracks and leaks. Replace components when necessary.
- ! Remove trash, grass, and other debris from around the cooling fins and recoil starter.(When doing this be sure to stop the engine and attached equipment and wait until the engine has cooled.)
- ! To prevent burns, do not touch the muffler or other engine parts that have become hot.
- ! Always use new gasoline (Using old gasoline could cause build up in the carburetor, which could cause poor engine operation.)
- ! Use genuine Grow engine parts. Not using genuine parts could result in engine damage and premature wear.
- ! **CAUTION** The important safety instruction items shown in this operation manual do not cover all possible statuses or conditions. Although we pay sufficient attention for safety, the person who uses or maintains the engine is requested to pay sufficient attention for safety as well.

COMPONENT NAMES

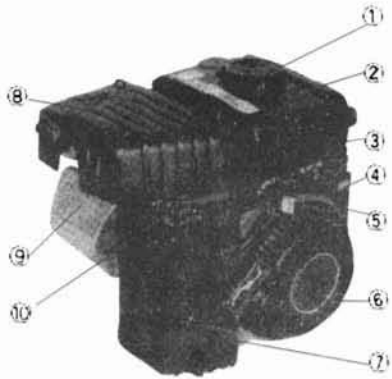

1. Fuel tank cap
2. Fuel tank
3. Speed control lever (Operating lever)
4. Engine switch
5. Fuel cock
6. Recoil starter grip
7. Air cleaner
8. Muffler
9. Cylinder head assy
10. Choke lever
11. Oil gauge & oil filler cap
12. Oil drain plug
13. Power take off shaft

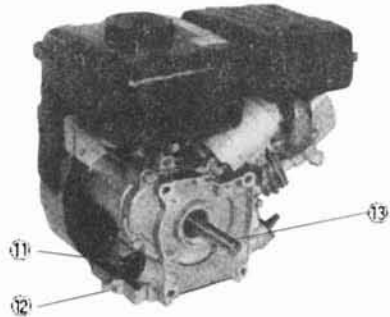

Note: Depending on the engine type, some components such as the fuel tank, engine switch, muffler and so on are not in the same position as the figure.

FUEL AND ENGINE OIL

FUEL

- Use clean, fresh, unleaded gasoline.(Do not use leaded gasoline.)
- Use gasoline within 30 days of purchase. Do not use old gasoline. Doing so could cause problems.
- Do not mix oil into the gasoline.
- Do not overflow the gasoline when filling the fuel tank.(Leave several centimeters of space at the top of the tank.)

! WARNING

- Flame and heat can cause gasoline to explode. Be sufficiently careful of flame and heat when handling gasoline.

ENGINE OIL

! Engine is shipped from Grow Develop Co. Ltd. without oil. Before starting the engine, be sure to conduct an oil inspection by following the instructions given below.

- ① Place the engine on a level surface when adding oil and conducting inspections.
 - ② Check the oil level without the oil gauge screwed in.
 - ③ Fill the oil up to the F-level of the oil gauge (correct level).
 - ④ Before starting the engine, tightly screw in the oil gauge.
- For oil, use high-quality pure API class oils with a grade of SD or higher or use SAE15W-40SF
 - Do not add commercial additives to the recommended oil. Do not mix gasoline into the oil.

PRE-OPERATION ENGINE INSPECTION

! **BE SURE** to check the following before operating the engine.

① Fuel inspection

- Is there gasoline in the tank?
- Is old gasoline being used?
- Add the correct fuel following the instructions on page 6 "FUEL AND ENGINE OIL".
- Is the fuel tank cap closed correctly?

! **WARNING** ● Be sufficiently careful of heat and flame when handling and adding fuel. Not doing so could cause a fire or explosion.

② Air cleaner inspection

- Is the air cleaner element dirty or is the air cleaner oil (oil bath type) insufficient?
- When the air cleaner element is dirty or oil in the air cleaner is dirty or insufficient, check and maintain according to page 9 "CARE OF THE ENGINE" and page 11 "INSPECTION AND MAINTENANCE".

③ Engine oil inspection

- Is the engine filled with the specified amount of engine? And is the oil dirty?
- If there is not enough oil, if it is dirty, or it has been used longer than the specified time, follow the inspection and maintenance instructions on page 6 "FUEL AND ENGINE OIL" and page 9 "CARE OF THE ENGINE".

⑥ Fuel and oil leaks inspection

- Are there any fuel or oil leaks?
- If any are found have the engine repaired.

④ Inspect the tightness of all fastener screws.

- Are all the screws tight?
- Be sure to check the screws used to fasten the muffler. (Do this when the muffler is cold.)

⑤ Component cleaning inspection

- Are there grass, leaves, or combustible materials around the muffler?
 - Are there grass, leaves, or combustible materials around the recoil starter air intake?
- If there is trash, etc., in the vicinity, be sure to remove it before operating the engine.

Standard capacity of oil quantity 0.4L.

STARTING AND STOPPING ENGINE

! Before starting the engine, carefully read and understand the "SAFE USE" and "PRE-OPERATION ENGINE INSPECTION" sections of this instruction manual.

Start process:

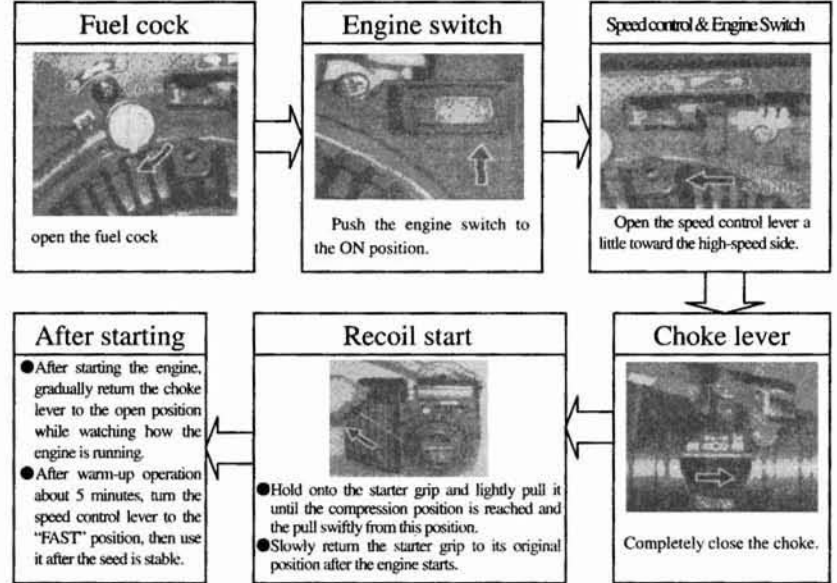

Stopping process:

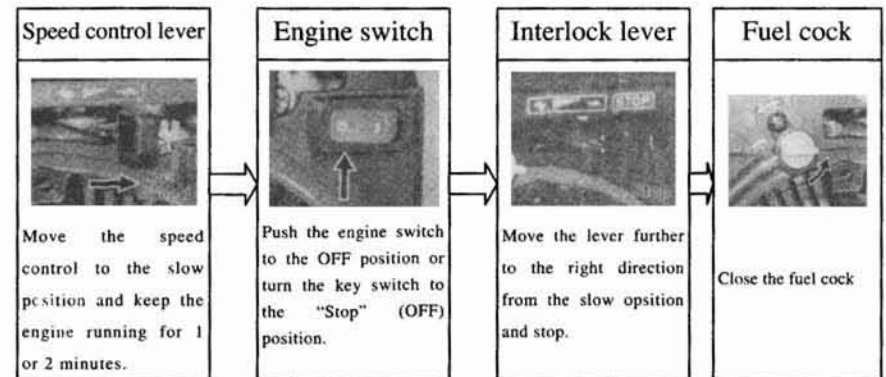

CARE OF THE ENGINE

! Daily and regular care of the engine is important to assure safe, proper, and long-term operation of the engine. Refer to the regular inspection table when conducting inspections and maintenance.

● Regular inspection table

Item \ Time	Before every operation	Every 25 hours	Every 50 hours	Every 100 hours
Inspection and tightening of bolt and nut at each place	○			
Engine oil level check and supply	○			
Change of engine oil		● Only the first time	○	
Check for fuel and oil leaks.	○			
Check and cleaning of air cleaner	○			
Cleaning around the recoil starter	○			
Cleaning of circumference of the muffler cover	○			
Check and cleaning of spark plug			○	
Removal of carbon in combustion chamber				◎
Check and adjustment of valve clearance				◎
Replace the fuel lines	3 years (or when necessary)			

Items marked with a “◎” require advanced skill and tools, so they should be done by the distributor.

! INSPECTION PRECAUTION ITEMS !

- ! Conduct inspections on a level and well-lit area.
- ! Detach the spark plug wires when conducting inspections and maintenance to prevent the engine from starting unintentionally.
- ! Immediately after operation the engine is hot, so do not touch it.
- ! When handling fuel (gasoline) absolutely do not use heat or flame.
- ! When fuel or oil has been spilled, completely wipe it up.
- ! Do not wash the engine with water.
- ! Do not unreasonably change the engine speed.
- ! The inspection times listed in the regular inspection table are at best recommended for general use conditions. The equipment used or the work area could cause engine operation to degrade from debris or dust. In such a case, stop work and clean the engine in a safe area.

INSPECTION AND MAINTENANCE

-----Before each operation-----

Adding engine oil

Be sure to check the amount oil before each operation and fill the reservoir to the proper level. Change the oil if it is dirty.

Cleaning and inspecting components

Clean the area around the muffler cover.
(Remove trash, etc.)
Inspect and tighten all nuts and bolts.
(Are the muffler nuts loose?)
Clean around the recoil starter.
(Remove trash, etc.)
Inspect fuel spills and oil leaks.
(Completely wipe away fuel spills.)

Air cleaner inspection and maintenance

● When the element is very dirty or when the oil has been used up making the element dry, after cleaning the element soak it in kerosene and strongly wring out the element with one hand.

! **Use of heat or flame is absolutely prohibited.**

----- First 25 hours and each 50 hours of operation -----

Change the engine oil

(Only the first 25 hours)
while the engine is still warm, drain the oil from the drain plug and replace it with new oil.

Clean maintain the spark plug

Remove the carbon attached to the electrode, polish the electrode with emery paper, and adjust the electrode gap 0.7mm.

! Burns could be caused by hot oil touching the skin, so be sufficiently careful.

Spark plug product Nos.

Manufacturer name	NGK	Denso	Champion	Nanjing
Product No.	Bp6HS	W20FB	L66Y	E6TC

LONG-TERM STORAGE

1. If the engine is not used for more than 30 days, changes in the fuel quality could cause poor engine starting, etc., so to prevent this loosen the fuel drain screw to drain out the fuel from the carburetor. Also open the fuel cock to drain the fuel from the fuel tank.

! **When doing this, be sufficiently careful in how the fuel is handled.**

! **Handling around heat or flame is absolutely prohibited.**

2. When storing the engine, remove the spark plug, pour 2 to 3 cc of engine oil into the cylinder, turn the crank shaft several times, replace the spark plug, and stop at the crank shaft at the point of compression.

3. Wipe the outside of the engine with a cloth soaked in oil.

! **Do not wash the engine with water.**

4. Store in a location with low humidity.

TROUBLE SHOOTING

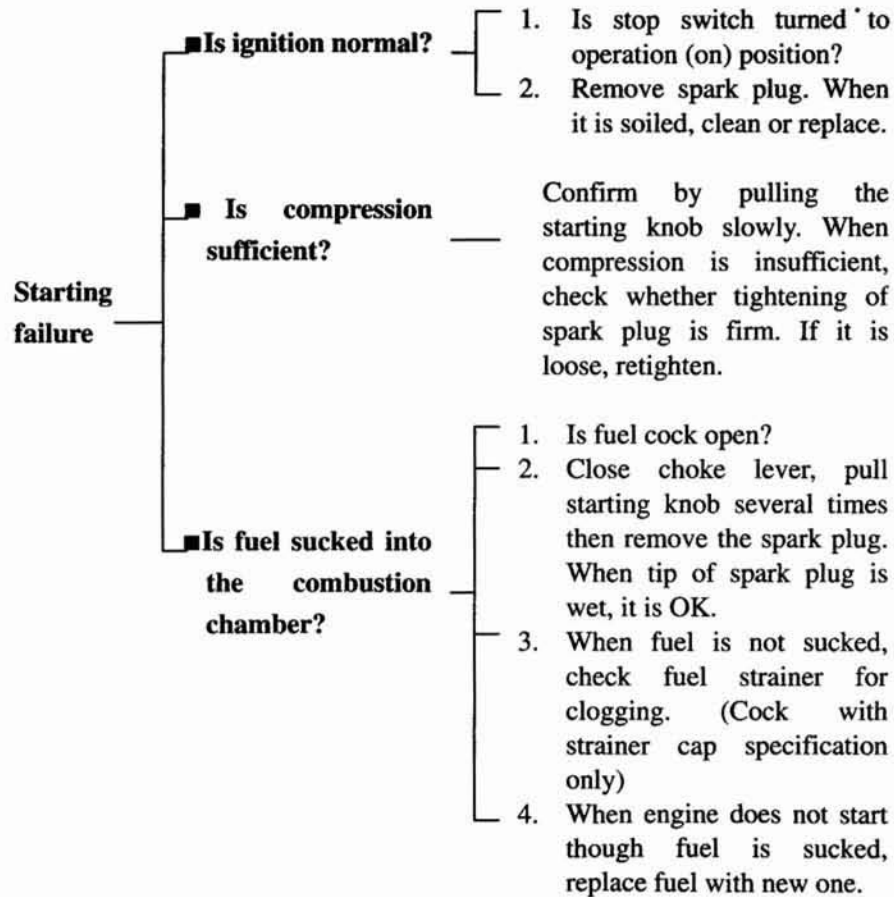

- When the engine does not start in spite of above mentioned inspection, ask the distributor or repair factory for inspection.

TECHNOLOGY PARAMETER

Cylinder diameter	52mm
Piston stroke	38mm
Exhaust capacity	80.7cc
Rated power	1.6hp/3000rpm
	1.8hp/3600rpm
Max power	2.4hp/4000rpm
Max torque	4.13N. m/3000rpm
Fuel type	90# no-lead gasoline
Oil type	SAE15W-40SF
Oil capability	0.4L
Compress ratio	7:1
Ignition	TCI
Plug clearance	0.7mm
Valve clearance	Intake valve(cold condition): 0.1mm
	Exhaust valve(cold condition): 0.15mm