

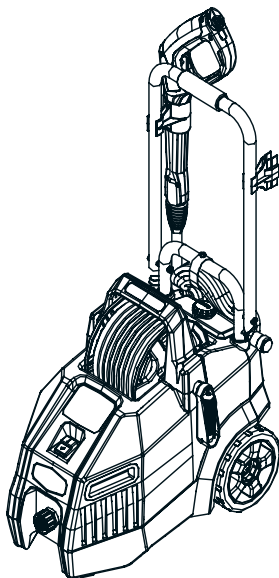

hydroworks™

**1600 PSI / 1.3 GPM
ELECTRIC PRESSURE WASHER**

51032



OPERATOR'S MANUAL

TOLL-FREE HELPLINE: 1-888-90WORKS (888.909.6757)

⚠ Read all safety rules and instructions carefully before operating this tool.

TABLE OF CONTENTS

Introduction.....	2
Important Safety Instructions.....	3
Specific Safety Rules.....	4-5
Symbols.....	6-7
Electrical.....	8
Know Your Pressure Washer.....	9
Assembly.....	10-13
Operation.....	14-18
Maintenance.....	19-21
Troubleshooting.....	22-24
Warranty.....	25
Exploded View.....	26
Part List.....	27-29

PRODUCT SPECIFICATIONS

Universal Motor.....	120 V, 60 Hz, 13 Amps
Max. Pounds Per Square Inch Pressure*.....	1600 psi
Rated Gallons Per Minute*.....	1,3 gpm
Maximum Inlet Water Temperature.....	104°F
Unit Weight.....	28 lbs (12.4 kg)



* Verified by the Power Washer Manufacturers' Association

IMPORTANT SAFETY INSTRUCTIONS

W A R N I N G

Read and understand all instructions. Failure to follow all instructions listed below may result in electric shock, fire, and/or serious personal injury.

W A R N I N G

When using this product basic precautions should always be followed, including the following:

READ ALL INSTRUCTIONS BEFORE USING THIS PRODUCT

- **To reduce the risk of injury**, close supervision is necessary when a product is used near children.
 - **Be thoroughly familiar with controls.** Know how to stop the product and release pressure quickly.
 - **Stay alert and exercise control.** Watch what you are doing and use common sense. Do not operate product when you are tired. Do not rush.
 - **Do not operate the product while under the influence of drugs, alcohol, or any medication.**
 - **Keep the area of operation clear of all persons**, particularly small children, and pets.
 - **Don't overreach or stand on unstable support.** Keep proper footing and balance at all times.
 - **Follow the maintenance instructions specified in this manual.**
 - **This product is provided with a ground fault circuit interrupter built into the power cord plug.** If replacement of the plug or cord is needed, use only identical replacement parts.
-

W A R N I N G

Risk of injection or injury – Do not direct discharge stream at people or animals.

GROUND FAULT CIRCUIT INTERRUPTER PROTECTION

- This pressure washer is provided with a ground fault circuit interrupter (GFCI) built into the plug of the power supply cord. This device provides additional protection from the risk of electric shock. Should replacement of the plug or cord become necessary, use only identical replacement parts that include GFCI protection.

EXTENSION CORDS

- Do not use with extension cord. Plug directly into receptacle.
-

W A R N I N G

To reduce the risk of electrocution, keep all connections dry and off the ground. Do not touch plug with wet hands.

SAVE THESE INSTRUCTIONS

SPECIFIC SAFETY RULES

- **Know your product.** Read the operator's manual carefully. Learn the machine's applications and limitations as well as the specific potential hazards related to this product.
- **To reduce the risk of injury,** keep children and visitors away. All visitors should wear safety glasses and be kept a safe distance from work area.
- **Use right product.** Don't force product or attachment to do a job it was not designed for. Don't use it for a purpose not intended.
- **Dress properly.** Do not wear loose clothing, gloves, neckties, or jewelry. They can get caught and draw you into moving parts. Rubber gloves and nonskid footwear are recommended when working outdoors. Also wear protective hair covering to contain long hair.
- **Do not operate the equipment while barefoot or when wearing sandals or similar lightweight footwear.** Wear protective footwear that will protect your feet and improve your footing on slippery surfaces.
- **Exercise caution to avoid slipping or falling.**
- **Always wear eye protection with side shields marked to comply with ANSI Z87.1.** Following this rule will reduce the risk of serious personal injury.
- **Use only recommended accessories.** The use of improper accessories may cause risk of injury.
- **Check damaged parts.** Before further use of the product, a guard or other part that is damaged should be carefully checked to determine that it will operate properly and perform its intended function. Check for alignment of moving parts, binding of moving parts, breakage of parts, mounting, and any other conditions that may affect its operation. A guard or other part that is damaged must be properly repaired or replaced by an authorized service center to avoid risk of personal injury.
- **Never leave product running unattended.** Turn power off. Don't leave product until it comes to a complete stop.
- **Keep the motor free of grass, leaves,** or grease to reduce the chance of a fire hazard.
- **Follow manufacturer's recommendations for safe loading, unloading, transport, and storage of machine.**
- **Keep product dry, clean, and free from oil and grease.** Always use a clean cloth when cleaning. Never use brake fluids, gasoline, petroleum-based products, or any solvents to clean product.
- **Check the work area before each use.** Remove all objects such as rocks, broken glass, nails, wire, or string which can be thrown or become entangled in the machine.
- **Do not use product if switch does not turn it off.** Have defective switches replaced by an authorized service center.
- **Avoid dangerous environment.** Don't expose to rain. Keep work area well lit.
- **Do not abuse the cord.** Never use the cord to carry the product or to disconnect the plug from an outlet. Keep cord away from heat, oil, sharp edges, or moving parts. Replace damaged cords immediately. Damaged cords increase the risk of electric shock.
- **Ground Fault Circuit Interrupter (GFCI) protection should be provided on the circuit(s) or outlet(s) to be used for the product.** Receptacles are available having built-in GFCI protection and may be used for this measure of safety.
- **Never direct a water stream toward people or pets, or any electrical device.**
- **Before starting any cleaning operation,** close doors and windows. Clear the area to be cleaned of debris, toys, outdoor furniture, or other objects that could create a hazard.
- **Do not use acids, alkalines, solvents, flammable material, bleaches, or industrial grade solutions** in this product. These products can cause physical injuries to the operator and irreversible damage to the machine.

SPECIFIC SAFETY RULES

W A R N I N G

High pressure jets can be dangerous if subject to misuse. The jet must not be directed at people, animals, electrical devices, or the machine itself.

- **Keep the motor away from flammables and other hazardous materials.**
 - **Check bolts and nuts** for looseness before each use. A loose bolt or nut may cause serious motor problems.
 - **Before storing**, allow the motor to cool.
 - **When servicing use only identical replacement parts.** Use of any other parts may create a hazard or cause product damage.
 - **ONLY** use cold water.
 - **Make sure minimum clearance** of 3 feet is maintained from combustible materials.
 - **Connect pressure washer only to an individual branch circuit.**
 - **Hold the handle and wand securely with both hands.** Expect the trigger handle to move when the trigger is pulled due to reaction forces. Failure to do so could cause loss of control and injury to yourself and others.
 - **Save these instructions.** Refer to them frequently and use them to instruct other users. If you loan someone this product, loan them these instructions also.
-

W A R N I N G









Some dust created by power sanding, sawing, grinding, drilling, and other construction activities contains chemicals known to cause cancer, birth defects or other reproductive harm. Some examples of these chemicals are:

- Lead from lead-based paints
 - Crystalline silica from bricks and cement and other masonry products
 - Arsenic and chromium from chemically-treated lumber. Your risk from these exposures varies, depending on how often you do this type of work. To reduce your exposure to these chemicals: work in a well ventilated area, and work with approved safety equipment, such as those dust masks that are specially designed to filter out microscopic particles.
-

SAVE THESE INSTRUCTIONS

SYMBOLS



Some of the following symbols may be used on this product. Please study them and learn their meaning. Proper interpretation of these symbols will allow you to operate the product better and safer.

SYMBOL	NAME	DESIGNATION/EXPLANATION
V	Volts	Voltage
A	Amperes	Current
Hz	Hertz	Frequency (cycles per second)
W	Watt	Power
no	No Load Speed	Rotational speed, at no load
~	Alternating Current	Type of current
.../min	Per Minute	Revolutions, strokes, surface speed, orbits etc., per minute
	Class II Construction	Double-insulated construction
	Safety Alert	Indicates a potential personal injury hazard.
	Read Operator's Manual	To reduce the risk of injury, user must read and understand operator's manual before using this product.
	Eye Protection	Always wear eye protection with side shields marked to comply with ANSI Z87.1.
	Wet Conditions Alert	Do not expose to rain or use in damp locations.
	Risk of Injection	To reduce the risk of injection or injury, never direct a water stream towards people or pets or place any body part in the stream. Leaking hoses and fittings are also capable of causing injection injury. Do not hold hoses or fittings.
	Kickback	To reduce the risk of injury from kickback, hold the spray wand securely with both hands when the machine is on.
	Electric Shock	Failure to use in dry conditions and to observe safe practices can result in electric shock.

SYMBOLS

SYMBOL	NAME	DESIGNATION/EXPLANATION
	Chemical Burns	To reduce the risk of injury or damage, DO NOT USE ACIDS, ALKALINES, BLEACHES, SOLVENTS, FLAMMABLE MATERIAL, OR INDUSTRIAL GRADE SOLUTIONS in this product.

The following signal words and meanings are intended to explain the levels of risk associated with this product.

SYMBOL	SIGNAL	MEANING
	DANGER	Indicates an imminently hazardous situation, which, if not avoided, will result in death or serious injury.
	WARNING	Indicates a potentially hazardous situation, which, if not avoided, could result in death or serious injury.
	CAUTION	Indicates a potentially hazardous situation, which, if not avoided, may result in minor or moderate injury.
	CAUTION	(Without Safety Alert Symbol) Indicates a situation that may result in property damage.

SERVICE

Servicing requires extreme care and knowledge and should be performed only by a qualified service technician. For service we suggest you return the product to your nearest **AUTHORIZED SERVICE CENTER** for repair. When servicing, use only identical replacement parts.

W A R N I N G

To avoid serious personal injury, do not attempt to use this product until you read thoroughly and understand completely the operator's manual. If you do not understand the warnings and instructions in the operator's manual, do not use this product. Call HYDROWORKS customer service for assistance.

W A R N I N G



The operation of any power tool can result in foreign objects being thrown into your eyes, which can result in severe eye damage. Before beginning power tool operation, always wear safety goggles or safety glasses with side shields and, when needed, a full face shield. We recommend Wide Vision Safety Mask for use over eyeglasses or standard safety glasses with side shields. Always use eye protection which is marked to comply with ANSI Z87.1.

ELECTRICAL

WARNING

The double insulated system is intended to protect the user from shock resulting from a break in the product's internal insulation. Observe all normal safety precautions to avoid electrical shock.

DOUBLE INSULATED

Double insulation is a concept in safety in electric power tools, which eliminates the need for the usual three-wire grounded power cord. All exposed metal parts are isolated from the internal metal motor components with protecting insulation. Double insulated products do not need to be grounded.

NOTE: Servicing of a product with double insulation requires extreme care and knowledge of the system and should be performed only by a qualified service technician. For service, we suggest you return the product to your nearest authorized service center for repair. Always use original factory replacement parts when servicing.

ELECTRICAL CONNECTION

This product has a precision-built electric motor. It should be connected to a power supply that is 120 volts, AC only (normal household current), 60 Hz. Do not operate this product on direct current (DC). A substantial voltage drop will cause a loss of power and the motor will overheat. If the product does not operate when plugged into an outlet, double-check the power supply.

WARNING

Keep the cord clear of the working area. Position the cord so that it will not get caught on lumber, tools, or other obstructions while you are working with a power tool. Failure to do so can result in serious personal injury.

GROUND FAULT CIRCUIT INTERRUPTER

This unit is equipped with a Ground Fault Circuit Interrupter (GFCI), which guards against the hazards of ground fault currents. An example of ground fault current is the current that would flow through a person who is using an appliance with faulty insulation and, at the same time, is in contact with an electrical ground such as a plumbing fixture, wet floor, or earth.

GFCI plugs do not protect against short circuits, overloads, or shocks.

WARNING

TO PROTECT AGAINST ELECTRIC SHOCK TEST BEFORE EACH USE

- PLUG INTO RECEPTACLE
- IF THE GFCI LIGHT IS NOT ON, PRESS THE RESET BUTTON, THE LIGHT SHOULD COME ON
- PRESS TEST BUTTON, LIGHT MUST GO OFF
- PRESS RESET BUTTON AGAIN FOR USE

DO NOT USE IF TEST FAILS

DO NOT USE AN EXTENSION CORD TO SUPPLY POWER TO THIS DEVICE

RAINPROOF

DO NOT IMMERSE

KNOW YOUR PRESSURE WASHER

The safe use of this product requires an understanding of the information on the tool and in this operator's manual as well as a knowledge of the project you are attempting. Before use of this product, familiarize yourself with all operating features and safety rules. (See Figure 1.)

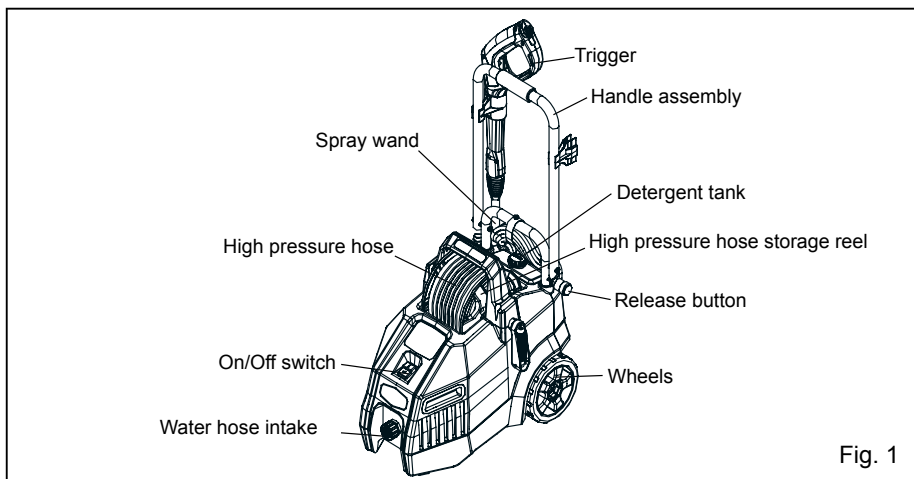

DETERGENT TANK

Remove the cap from the detergent tank to add detergent to the pressure washer.

GFCI PLUG

The pressure washer is equipped with a GFCI plug to guard against the hazards of ground fault currents. This plug does not protect against short circuits, overloads, or shocks.

HIGH PRESSURE HOSE STORAGE REEL

A convenient hose reel stores the high pressure hose when the pressure washer is not in use.

ON / OFF SWITCH

This switch turns the pressure washer on and off.

FOLDING HANDLE

The folding handle allows the handle to be lowered for convenient storage.

TRIGGER HANDLE

The trigger handle has a gripping surface that provides added control of the spray wand and helps reduce fatigue.

TRIGGER WITH LOCK-OUT

Pulling the trigger releases a stream of water for high pressure cleaning. The lock-out provides protection against unintentional use.

ASSEMBLY

UNPACKING

This product requires assembly.

- Carefully remove the product and any accessories from the box. Make sure that all items listed in the packing list are included.

WARNING

Do not use this product if any parts on the Packing List are already assembled to your product when you unpack it. Parts on this list are not assembled to the product by the manufacturer and require customer installation. Use of a product that may have been improperly assembled could result in serious personal injury.

- Inspect the product carefully to make sure no breakage or damage occurred during shipping.
- Do not discard the packing material until you have carefully inspected and satisfactorily operated the product.
- If any parts are damaged or missing, please call 1-888-909-6757 for assistance.

PACKING LIST
Pressure Washer with 25 ft. High Pressure Hose
Operator's manual
Spray gun
Lance
Quick release velcro strap
Net bag
Variable nozzle
Rotating brush

WARNING

If any parts are damaged or missing do not operate this product until the parts are replaced. Use of this product with damaged or missing parts could result in serious personal injury.

WARNING

Do not attempt to modify this product or create accessories not recommended for use with this product. Any such alteration or modification is misuse and could result in a hazardous condition leading to possible serious personal injury.

WARNING

Do not connect to power supply until assembly is complete. Failure to comply could result in accidental starting and possible serious personal injury.

ASSEMBLY

OPERATING THE HANDLE ASSEMBLY (See Figure 2.)

- Open for use: Lift up on the handle bar pivoting it towards the back into an upright position until it clicks and locks into place.
- To fold the handle, pull the latch sideways, and push the handle down and forward.

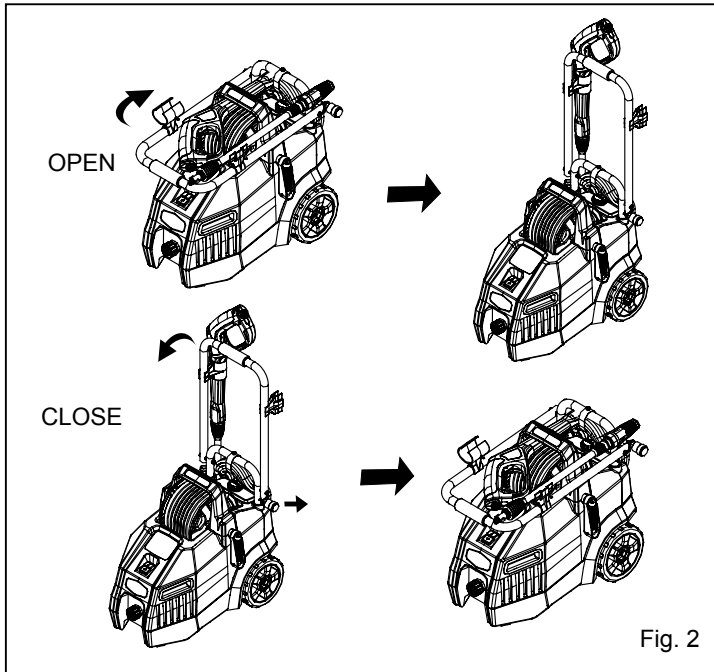

ASSEMBLY

INSTALLING THE SPRAY WAND (See Figure 3.)

•To assemble the pressure washer wand, insert the upper half into the lower half, and twist.

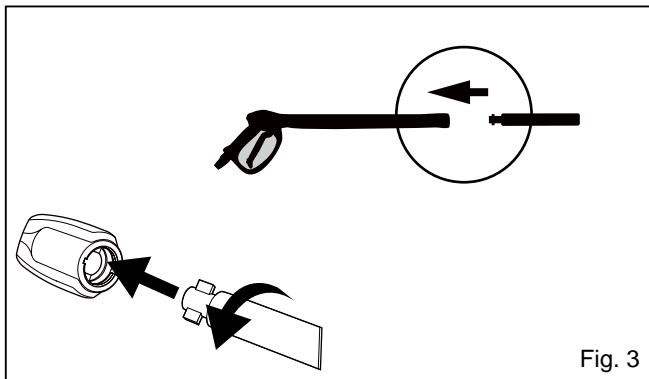

CONNECTING HIGH PRESSURE HOSE TO TRIGGER HANDLE (See Figure 4.)

- Connect the high pressure hose to the trigger handle.
- Insert high pressure hose into trigger handle.
- Push tab lock toward handle to secure hose.

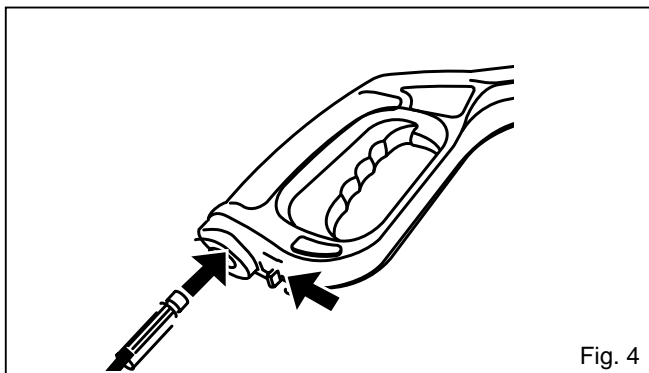

ASSEMBLY

CONNECTING THE GARDEN HOSE (See Figure 5.)

CAUTION :

Always observe all local regulations when connecting hoses to the water main. Some areas have restrictions against connecting directly to public drinking water supply to prevent the feedback of chemicals into the drinking water supply. Direct connection through a receiver tank or backflow preventer is usually permitted.

- Uncoil the garden hose.

NOTE: There must be a minimum of 10 feet of unrestricted garden hose between the water intake and the garden hose faucet or shut off valve (such as a "Y" shut off connector).

- Run water through the garden hose for 30 seconds to clean any debris from the hose.
- Inspect the screen in the water intake.
- If the screen is damaged, do not use the machine until the screen has been replaced.
- If the screen is dirty, clean it before connecting the garden hose to the machine.
- With the hose faucet turned completely off, attach the end of the garden hose to the water intake. Tighten by hand only.

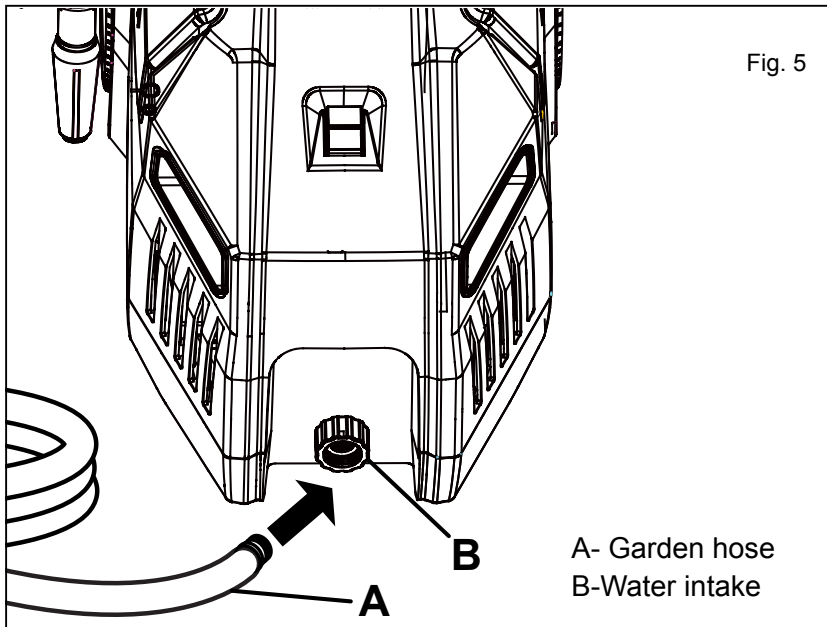

ASSEMBLY

INSTALLING THE ROTATING BRUSH

- Turn off the pressure washer and shut off the water supply. Pull trigger to release pressure.
- Engage the lock-out on the trigger handle by pushing the trigger lock button to the right.
- To assemble the rotating brush, insert the brush wand into the pressure washer wand, and twist.

Applications: Ideal for cleaning most smooth surfaces, including vehicles, boats, outdoor furniture, fabrics, plastics, fiberglass, glass, and windows.

W A R N I N G :

To reduce the risk of injury, user must read and understand the operator's manual for this pressure washer and this accessory. Wear eye protection marked to comply with Z87.1. Ensure compatibility and fit before using this accessory. Turn off the pressure washer before changing or adjusting accessories. For cold water use only. Do not use this accessory if damaged or if a part is missing. Dirt and debris can damage delicate surfaces. Thoroughly rinse the brush before use and continue to do so at regular intervals during use. Thoroughly clean the brush after use. Allow to dry and always store brush without bending the bristles. Save these instructions. Refer to them frequently and use them to instruct other users. If you loan someone this tool, loan them these instructions also.

OPERATION

W A R N I N G

Do not allow familiarity with the product to make you careless. Remember that a careless fraction of a second is sufficient to inflict serious injury.

W A R N I N G

Always wear eye protection with side shields marked to comply with ANSI Z87.1. Failure to do so could result in objects being thrown into your eyes resulting in possible serious injury.

W A R N I N G

Do not use any attachments or accessories not recommended by the manufacturer of this product. The use of attachments or accessories not recommended can result in serious personal injury.

W A R N I N G

Never direct a water stream toward people or pets, or any electrical device. Failure to heed this warning could result in serious injury.

APPLICATIONS

You may use this product for the purposes listed below:

- Cleaning boats, cars, trucks, motorcycles, outdoor furniture, grills, house siding, driveways, patios and decks.

OPERATION

DETERGENT ADDING AND USE *(See Figure 6-1.)*

Use only detergents designed for pressure washers; household detergents, acids, alkalines, bleaches, solvents, flammable material, or industrial grade solutions can damage the pump. Many detergents may require mixing prior to use. Prepare cleaning solution as instructed on the solution bottle.

To add:

- Disconnect pressure washer from power supply.
- Place pressure washer upright on a flat surface.
- Remove cap from detergent tank.
- Pour detergent into tank.

To use:

CAUTION

Use only approved pressure washer cleaners. Do not use bleach, chlorine, or any cleaners containing acids.

- Connect black soap nozzle to the wand connector. *(See Figure 6-2.)*
- Squeeze the trigger and the detergent will automatically be mixed with the water and dispensed from the nozzle.

NOTE: Use a funnel, if needed, to prevent accidental spilling of the detergent outside the tank. If any detergent is spilled during the filling process, make sure the unit is cleaned and dried before proceeding.

- Reinstall cap.

PUMP LUBRICANT

The pressure washer pump has been filled with sufficient lubricant at the factory and is maintenance free. You do not need to check or add lubricant to the pump before initial use.

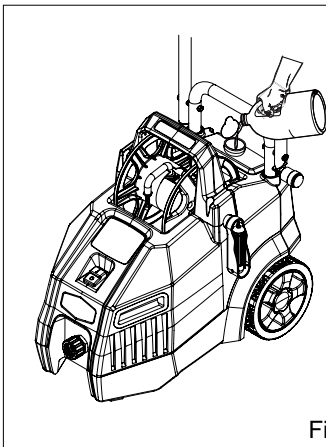

Fig. 6-1

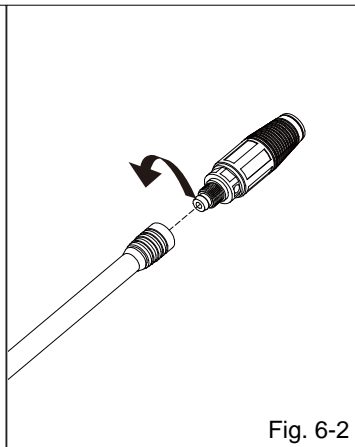

Fig. 6-2

OPERATION

STARTING AND STOPPING THE PRESSURE WASHER (See Figure 7.)

CAUTION :

Do not run the pump without the water supply connected and turned on.

- Connect the garden hose.
- Turn the garden hose on then squeeze the trigger to relieve air pressure. Once a steady stream of water appears, release the trigger.
- After ensuring the On/Off switch is in the OFF (O) position, connect the pressure washer to the power supply.
- Press the reset button on the pressure washer's plug to make sure the unit is ready for operation.

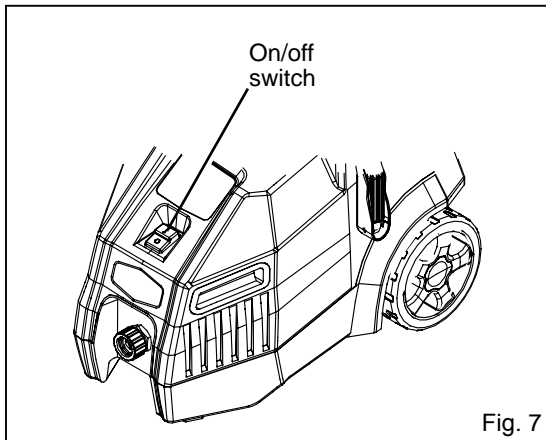

- Press ON (I) on the switch to start the motor.
- To stop the motor, release the trigger and press OFF(O) on the switch.

NOTE: The pressure washer may be on and the system may have pressure even when the pump and/or motor cannot be heard running. Always use caution around the pressure washer.

⚠ WARNING

Hold the trigger handle securely with both hands. Expect the trigger handle to move when the trigger is pulled due to reaction forces. Failure to do so could cause loss of control and injury to yourself and others.

OPERATION

USING THE SPRAY WAND TRIGGER (See Figure 8.)

For greater control and safety, keep both hands on the trigger handle at all times.

- Pull back and hold the trigger to operate the pressure washer.
- Release the trigger to stop the flow of water through the nozzle.

TO ENGAGE THE LOCK-OUT:

- Slide the lock-out button to the right side of the trigger handle to engage the lock-out.

TO DISENGAGE THE LOCK-OUT:

- Slide the lock-out button to the left side of the trigger handle to disengage the lock-out.

For the most effective cleaning, the spray nozzle should be between 8 in. and 24 in. from the surface to be cleaned. If the spray is too close it can damage the cleaning surface.

⚠ WARNING

Do not slide lock-out button when you have the trigger at back position.

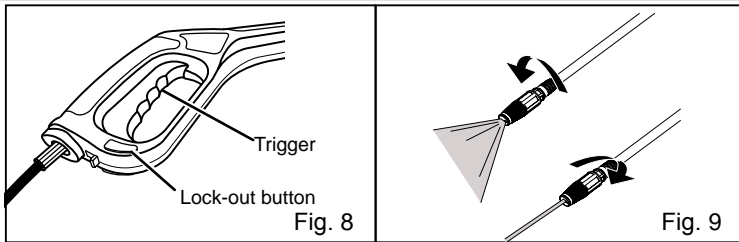

USING VARIABLE SPRAY NOZZLE (See Figure 9.)

The variable spray nozzle can adjust from fan to pencil point spray in both the high and low pressure positions. The spray can be adjusted by turning the nozzle head.

NOTE: Always try nozzle in an inconspicuous area first.

⚠ WARNING

NEVER change nozzles without engaging the lock-out on the trigger handle and NEVER point the wand at your face or at others. The quick-connect feature contains small springs that could eject the nozzle with some force. Failure to heed this may cause personal injury.

- Turn off the pressure washer and shut off the water supply. Pull trigger to release water pressure.
- Engage the lock-out on the trigger handle by pushing the trigger lock button to the right.
- Pull back the quick-connect collar.
- Push the nozzle into place in the spray wand.
- Push the collar forward so that the nozzle is secured properly. Check to see that the nozzle is secure.

TO DISCONNECT A NOZZLE FROM THE TRIGGER HANDLE ONCE THE CLEANING JOB IS COMPLETE:

- Turn off the pressure washer and shut off the water supply. Pull trigger to release water pressure.
 - Engage the lock-out on the trigger handle by pushing the trigger lock button to the right.
 - Remove the nozzle by placing hand over nozzle then pulling back the quick-connect collar. Place nozzle in the nozzle storage area on the trigger handle.
-

OPERATION

OPERATING THE PRESSURE WASHER (See Figure 10.)

Use only detergents designed for pressure washers. Many detergents may require mixing prior to use. Prepare cleaning solution as instructed on the solution bottle.

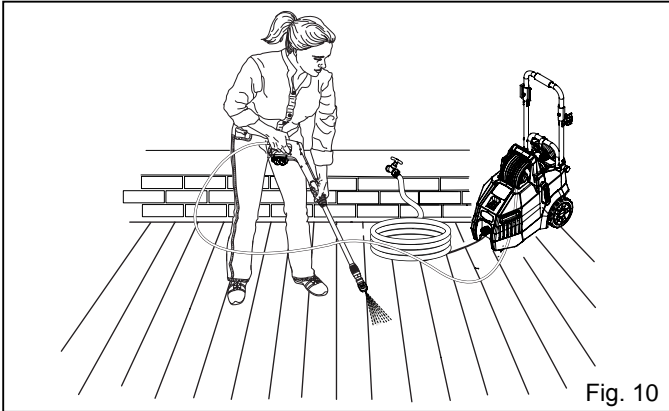

To clean:

- Pour detergent in the detergent tank.
- Install the black soap nozzle on the spray wand.
- Start the pressure washer and spray the detergent on a dry surface using long, even, overlapping strokes. To prevent streaking, do not allow detergent to dry on the surface.

To rinse:

- Using the variable spray nozzle, spray away from the rinsing surface for approximately 10 seconds to allow any remaining detergent to be flushed from the line.
- Start at the top of the area to be rinsed and work down, overlapping the strokes.

MOVING THE PRESSURE WASHER

To move the pressure washer:

- Turn the pressure washer off. Point nozzle in a safe direction and pull trigger to release water pressure.
- Raise the handle up until the buttons click into the holes on the handle.
- Tilt the machine toward you until it balances on the wheels then roll the machine to the desired position.

MAINTENANCE

⚠ WARNING

When servicing, use only identical replacement parts. Use of any other parts may create a hazard or cause product damage.

⚠ WARNING

Always wear eye protection marked to comply with ANSI Z87.1. Failure to do so could result in objects being thrown into your eyes, resulting in possible serious injury.

⚠ WARNING

Before inspecting, cleaning or servicing the machine, shut off engine, wait for all moving parts to stop, and disconnect spark plug wire and move it away from spark plug. Failure to follow these instructions can result in serious personal injury or property damage.

GENERAL MAINTENANCE

Avoid using solvents when cleaning plastic parts. Most plastics are susceptible to damage from various types of commercial solvents and may be damaged by their use. Use clean cloths to remove dirt, dust, oil, grease, etc.

⚠ WARNING

Do not at any time let brake fluids, gasoline, petroleum-based products, penetrating oils, etc., come in contact with plastic parts. Chemicals can damage, weaken or destroy plastic which may result in serious personal injury.

Only the parts shown on the parts list are intended to be repaired or replaced by the customer. All other parts should be replaced at an authorized service center.

NOZZLE MAINTENANCE (See Figure 11.)

Excessive pump pressure (a pulsing sensation felt while squeezing the trigger) may be the result of a clogged or dirty nozzle.

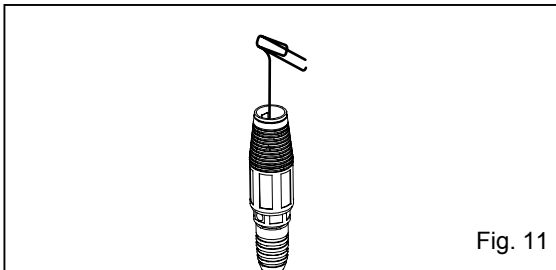

Fig. 11

MAINTENANCE

- Unplug the pressure washer.
- Turn off the pressure washer and shut off the water supply. Pull trigger to release water pressure.
- Remove the nozzle from the spray wand.

NOTE: Never point the spray wand at your face

Using a straightened paper clip or nozzle cleaning tool (not provided), free any foreign materials clogging or restricting the nozzle.

- Using a garden hose, flush debris out of nozzle by back flushing (running the water through the nozzle backwards or from the outside to the inside).
- Reconnect the nozzle to the spray wand.
- Turn on the water supply.

STORING THE PRESSURE WASHER

Store in a dry, covered area where the weather can't damage it.

It is important to store this product in a frost-free area. Always empty water from all hoses, the pump, and the detergent container before storing.

NOTE: Use of a pump saver will give you better performance and increase the life of the machine.

QUICK WINTERIZING PROCEDURE

If you cannot do the Optimum Winterizing procedure, you can still protect your pressure washer from winter-damage by following the steps below:

- Disconnect all water connections.
- Turn on the machine for a few second, until the remaining water in the pump exits. Turn off immediately.
- Do not allow high-pressure hose to become kinked.
- Store the machine and accessories in a room that does not reach freezing temperatures. Do not store near furnace or other sources of heat as it may dry out the pump seals.

CAUTION :

Drain gun assembly of any remaining water. Aim gun downwards and aqueeze trigger.

SHUTTING DOWN AND CLEANING UP

- (if you are not using detergent, go directly to Step 2.) When you have finished using the detergent injection system, fill detergent bottle with clean water. Siphon water at low-pressure for one minute so that all detergent is flushed through system. Remove detergent bottle and rinse it thoroughly.
- Disconnect the garden hose from the water inlet on the unit.
- Press trigger to release any remaining water pressure.
- Turn the switch to "OFF" (0) position.
- Unplug the power cord from the outlet.
- Engage gun safety lock.

WARNING

Turn off water supply and squeeze trigger to depressurize the unit. Failure to do so could result in personal injury due to discharge of high-pressure water.

MAINTENANCE

TAKING A BREAK

If taking a break of five minutes or more.

- Engage gun safety lock.
 - Turn unit to “OFF” (O) position.
 - **Unplug the power cord from the outlet.**
-

C A U T I O N :

The use of a pump protector is recommended to prevent cold weather damage during storage over the winter months.

TROUBLESHOOTING

PROBLEM	POSSIBLE CAUSE	SOLUTION
Motor will not start.	On/Off switch is in the "OFF" (O) position.	Turn switch to the "ON" () position.
	Power cord is not plugged in.	Plug in power cord.
	Electrical outlet does not supply adequate power.	Try a different outlet.
	Tripped pressure washer temperature breaker	Allow to cool, and restart unit.
	Tripped circuit breaker	switch off pressure washer, squeeze trigger gun waiting for a steady flow of water emerge from spray nozzle, then turn on the unit. (ensure when you turn on the unit ,trigger gun at "on" position).
	Tripped CFCL plug	Press "RESET" button on GFCL plug.
Unit does not reach high pressure.	Diameter of garden hose is too small.	Replace with a 1" (25 mm) or 5/8" (16 mm) garden hose.
	Water supply is restricted.	Check garden hose for kinks, leaks and blockage.
	Not enough water supply.	Open water source fully.
	Water inlet filter is clogged.	Remove filter and rinse in warm water.
	Power nozzle is in low-pressure position.	Turn power nozzle to high-pressure position.
Output pressure varies high and low.	Not enough inlet water supply.	Turn water on fully. Check garden hose for kinks, leaks or blockage
	Pump is sucking air.	Check that hoses and fittings are airtight. Turn "OFF" machine, and purge pump by squeezing trigger gun until a steady flow of water emerges through the nozzle.
	Water inlet filter is clogged.	Remove filter and rinse with warm water.

TROUBLESHOOTING

PROBLEM	POSSIBLE CAUSE	SOLUTION
Output pressure varies high and low. (continued)	Discharge nozzle is obstructed.	Blow out or remove debris with a fine needle.
	Calcified gun, hose or power nozzle.	Run distilled vinegar through detergent tank.
Detergent is not coming out.	Is detergent tank selector on and the correct tank selected?	Select the correct tank, either A or B.
	Detergent bottle or suction tube not properly connected.	Check connections.
	Detergent is too thick.	Dilute detergent.
	Filter on detergent suction tube is clogged.	Run warm water through filter to remove build-up.
	Damaged or clogged detergent suction tube.	Remove obstruction or replace detergent suction tube.
	Nozzle is in high-pressure position.	Turn nozzle tip to low-pressure position.
	Discharge nozzle is obstructed.	Blow out or remove debris with a fine needle.
Garden hose connection leaks.	Loose fittings.	Tighten fittings.
	Missing/worn rubber washer.	Insert new washer.
Spray wand, extension, or nozzle leaks.	Broken o-ring or plastic insert.	Call the Toll-Free Hotline.
Pump is noisy	Pump is sucking air	Check that hoses and fittings are airtight. Turn off machine and purge pump by squeezing trigger gun until a steady flow of water emerges through the nozzle.
	Water filter is clogged.	Remove water filter and rinse in warm water.
Water leaks from pump (up to 10 drops per minute is permissible).	Loose fittings.	Check that all fittings are tight.
	Water seals are damaged or worn.	Call the Toll-Free Hotline
Oil is dripping	Oil seals are damaged or worn.	Call the Toll-Free Hotline

TROUBLESHOOTING

PROBLEM	POSSIBLE CAUSE	SOLUTION
Motor buzzes but fails to run.	Supply voltage below minimum.	Verify that only the pressure washer is running on this circuit.
	System has residual pressure.	Turn unit "OFF", squeeze trigger on spray wand to release pressure, then turn unit "ON"
	Voltage loss due to extension cord.	Unplug any extension cords attached and plug the unit directly into the outlet.
	Pressure washer not used for long periods.	Call the Toll-Free Hotline.
	Residual friction among components. Unit might hum.	Disconnect water supply and power ON for 2 to 3 seconds, repeat couple times or until the motor starts.
	Tripped circuit breaker	switch off pressure washer, squeeze trigger gun waiting for a steady flow of water emerge from spray nozzle, then turn on the unit. (ensure when you turn on the unit ,trigger gun at "on" position).
No Water	Quick connect assembly is attached in reverse.	Verify that Inlet adapter (G2) is attached to machine's water inlet and that the quick connect coupler (G1) is attached to garden hose.
	Water supply is OFF.	Turn ON water supply.
	Kink in the garden hose.	Remove kink in garden hose.

PLEASE NOTE:
THIS PRODUCT IS FITTED WITH A TOTAL STOP SWITCH. THIS MEANS THAT THE MOTOR WILL NOT RUN CONTINUOUSLY, IT WILL ONLY RUN WHEN THE TRIGGER ON THE HIGH PRESSURE WAND IS ACTIVATED AND WATER IS FLOWING.

WARRANTY



HYDROWORKS™ hereby warrants this product, to the original purchaser with proof of purchase, for a period of one (1) years against defects in materials, parts or workmanship. HYDROWORKS™, at its own discretion will repair or replace any and all parts found to be defective, through normal use, free of charge to the customer. This warranty is valid only for units which have been used for personal use that have not been hired or rented for industrial/ commercial use, and that have been maintained in accordance with the instructions in the owners' manual supplied with the product from new.

ITEMS NOT COVERED BY WARRANTY:

1. Any part that has become inoperative due to misuse, commercial use, abuse, neglect, accident, improper maintenance, or alteration; or
2. The unit, if it has not been operated and/or maintained in accordance with the owner's manual; or
3. Normal wear, except as noted below;
4. Routine maintenance items such as draining the water to avoid freezing/ice damage to pump and components.
5. Normal deterioration of the exterior finish due to use or exposure.

HYDROWORKS HELPLINE (1-888-90WORKS):

Warranty service is available by calling our toll-free helpline, 9am to 5pm EST. Monday – Friday at **1-888-909-6757 (1-888-90WORKS)**.

TRANSPORTATION CHARGES:

Transportation charges for the movement of any power equipment unit or attachment are the responsibility of the purchaser. It is the purchaser's responsibility to pay transportation charges for any part submitted for replacement under this warranty unless such return is requested in writing by HYDROWORKS.

EXPLODED VIEW

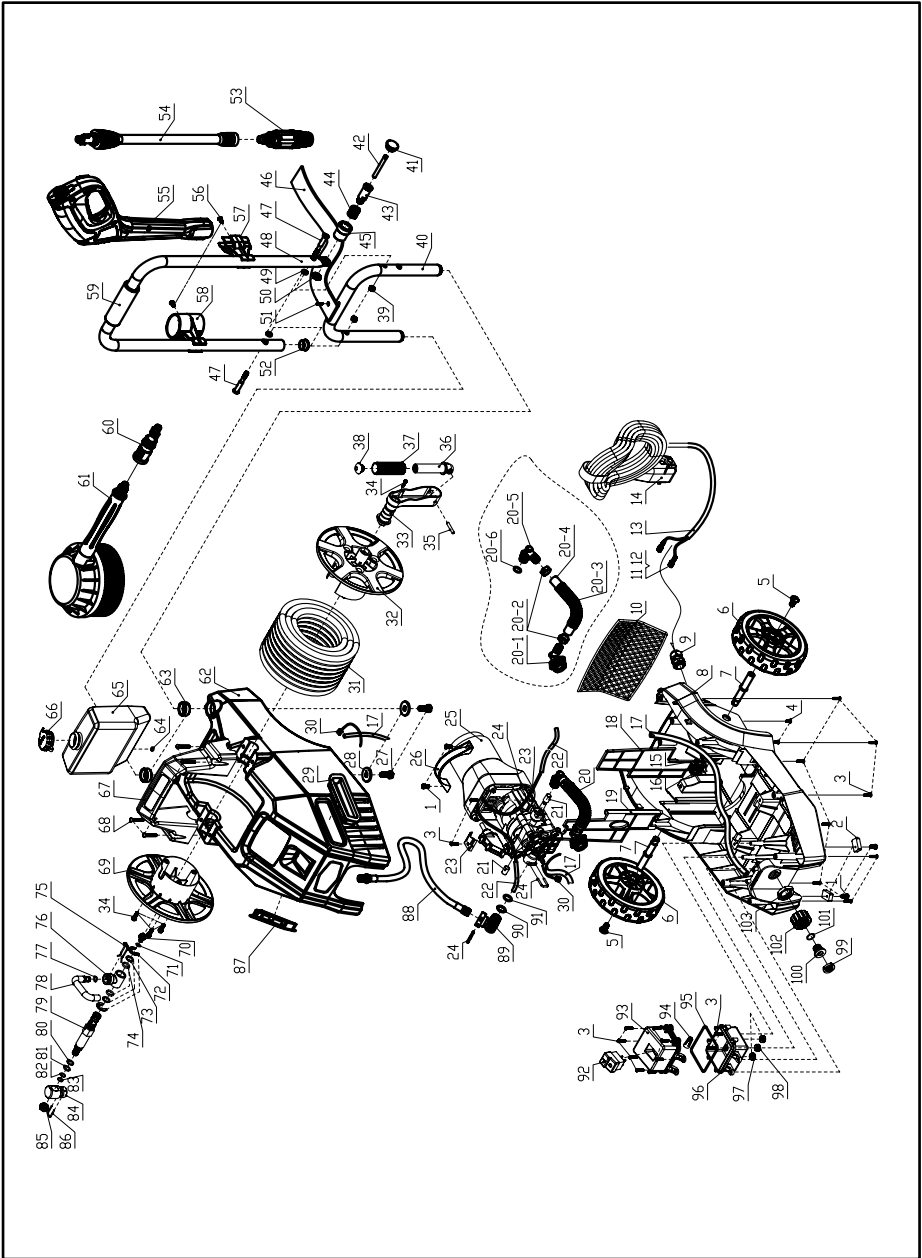

PARTS LIST

ITEM NO.	PART NO.	DESCRIPTION	QTY
1	32202368	Taping screw ST4*12-F	4
2	34202365	Foot pad	2
3	32201368	Taping screw ST4.2X16-F	20
4	32213365	Taping screw ST4x10-F	2
5	33210365	Nut M8*16	2
6	34134365	Wheel assy	2
7	33201365	Axile	2
8	34101365	Lower housing	1
9	31101365	Grommet	1
10	34901363	Mesh	1
11	36501154	straight terminal	2
12	36503301	terminal sleeves	2
13	36401365	Power cord	1
14	36301302-1	GFCI plug	1
15	32308316A	washer	2
16	32907301A	hitch	2
17	34904365	soap hose	1
18	34108365	heat insulation board left	1
19	34107365	heat insulation board right	1
20	31109365	water inlet hose assy	1
20_1	34115365	water inlet connector 1	1
20_2	33911302	clip	2
20_3	33902365	hose spring	1
20_4	34901365	inlet hose	1
20_5	34116365	water inlet connector 2	1
20_6	34207363	o-ring	1
21	34203365	gasket	2
22	30303301	Fiber tube	2
23	33301365	clamp	2
24	33302365	U-clip	3
25	31130365	pump and motor assy	1
26	34106365	motor clamp	1
27	32202363	bolt	2
28	32901363	washer	2
29	34112365	right panel	1
30	3411275	velcro strap	2
31	31208319	High pressure hose assy	1

PARTS LIST

ITEM NO.	PART NO.	DESCRIPTION	QTY
32	34121363	Hose reel cover right	1
33	34123363	hose reel middle body	1
34	32205316A	Taping screw ST3.5X19	4
35	33203363	hitch	1
36	34124363	handle sleeve	1
37	34126363	hose reel handle	1
38	34127363	nut	1
39	32201100	Locking nyloc unt	2
40	33303365	low er handle	1
41	34119365	cap	1
42	33207365	pin	1
43	33206365	pin bushing	1
44	33901365	spring	1
45	34118365	sleeve	1
46	34905365	Power cord strap	1
47	33204365	pull rod shaft	2
48	33304365	upper handle	1
49	33305365	washer	2
50	33205365	nut M12X1	1
51	32210365	nut M6x10	1
52	34115363	cap	1
53	31210365	adjustable nozzle	1
54	31102973	wand assy	1
55	31107368	gun assy	1
56	32212316A	taping screw	2
57	34120365	wand holder	1
58	34121365	gun holder	1
59	34202363	foam grip	1
60	34122372	rotating brush	1
61	31121365	rotating brush connector	1
62	34102365	upper housing	1
63	34113365	ring	2
64	34220365	o-ring	1
65	34103365	soap tank	1
66	34201363	tank cap	1
67	34108363	lift handle	1
68	3220335	taping screw	4

PARTS LIST

ITEM NO.	PART NO.	DESCRIPTION	QTY
69	34122363	hose reel cover left	1
70	32204363	Nut M8X1	1
71	34238302	o-ring	1
72	33326319	E clip	2
73	34217319	retainer	2
74	34218319A	o-ring	2
75	33399363	pin	1
76	33220319	high pressure swivel	1
77	34209319A	o-ring	1
78	33217319	high pressure hose connector	1
79	33204363	Aluminum swivel	1
80	34209363	rubber ring	1
81	34207363	O-ring 11x2	1
82	34242302A	o-ring	1
83	34208363	rubber ring small	1
84	33205363	Aluminum connector	1
85	32905363	Nut	1
86	33398363	U-clip	1
87	34111365	left panel	1
88	31112363	high pressure hose	1
89	3310165	water putlet connector	1
90	34211365	retainer	1
91	34212363	o-ring	1
92	36301365	main switch	1
93	34110365	main switch cover	1
94	36511154	wire cap	1
95	34201365	gasket	1
96	34109365	main switch box	1
97	34223302	power cord grommet	2
98	34208304	Motor cable grommet	1
99	31901301	filter	1
100	33166307	water inlet connector	1
101	34213301	O ring	1
102	34124319	inlet nut	1
103	33127302	nut	1



TOLL-FREE HELPLINE: 1-888-90WORKS (888.909.6757)

Rev: 01 (02-10-11)

 Printed in China on 100% Recycled Paper