

# CHAMPION

POWER EQUIPMENT™

OWNER'S MANUAL & OPERATING INSTRUCTIONS



2650 PSI / 2.3 GPM

# PRESSURE WASHER



MODEL NUMBER  
**75520**

**SAVE THESE INSTRUCTIONS**  
Important Safety Instructions  
are included in this manual.

MADE IN CHINA  
REV 75520-20121219

10006 Santa Fe Springs Road  
Santa Fe Springs CA 90670  
USA / 1-877-338-0999  
[www.championpowerequipment.com](http://www.championpowerequipment.com)

**Have questions or need assistance?**

Do not return this product to the store!

**WE ARE HERE TO HELP!**

Visit our website:

**[www.championpowerequipment.com](http://www.championpowerequipment.com)**

for more info:

- Product Info & Updates
- Tech Bulletins
- Frequently Asked Questions
- Product Registration

– or –

Call our Customer Care Team Toll-Free at:

**1-877-338-0999**

**WARNING:**

The Engine Exhaust from this product contains chemicals known to the State of California to cause cancer, birth defects or other reproductive harm.

\*We are always working to improve our products. Therefore, the enclosed product may differ slightly from the image on the cover.

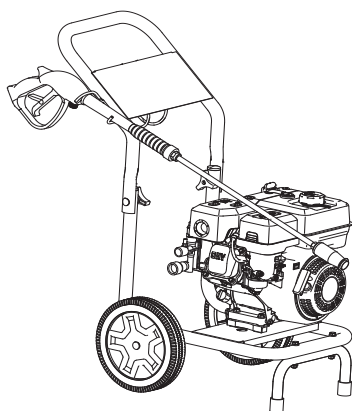

# 2650 PSI / 2.3 GPM PRESSURE WASHER

## TABLE OF CONTENTS

<b>Introduction</b> . . . . .	<b>1</b>	Maintenance Schedule . . . . .	15
Pressure Washer . . . . .	1	Pressure Washer Maintenance . . . . .	15
Accessories . . . . .	1	Cleaning Spray Nozzle . . . . .	15
This Booklet . . . . .	1	Storage . . . . .	15
<b>Manual Conventions</b> . . . . .	<b>2</b>	Engine Stored for Less than 30 days . . . . .	15
<b>Safety Rules</b> . . . . .	<b>3</b>	Engine Stored for Over 30 Days . . . . .	16
<b>Controls and Features</b> . . . . .	<b>5</b>	Pressure Washer Storage . . . . .	16
Pressure Washer . . . . .	5	Winter Storage . . . . .	16
Parts Included . . . . .	6	<b>Specifications</b> . . . . .	<b>17</b>
<b>Assembly</b> . . . . .	<b>7</b>	Engine Specifications . . . . .	17
Remove the Pressure Washer from the		Pressure Washer Specifications . . . . .	17
Shipping Carton . . . . .	7	Fuel . . . . .	17
Upper Frame Assembly . . . . .	7	Oil . . . . .	17
Wheel Assembly . . . . .	7	Spark Plugs . . . . .	17
Support Foot Assembly . . . . .	7	Maintenance Valve Clearance . . . . .	17
Add Engine Oil . . . . .	7	Troubleshooting . . . . .	18
Add Fuel . . . . .	8	Pressure Washer Parts Diagram . . . . .	19
Attach the Pressure Gun . . . . .	9	Pressure Washer Parts List . . . . .	20
Connect the High Pressure Hose . . . . .	9	Engine Parts Diagram . . . . .	21
Connect to Garden Hose . . . . .	9	Engine Parts List . . . . .	22
<b>Operation</b> . . . . .	<b>10</b>	<b>Warranty</b> . . . . .	<b>23</b>
Pressure Washer Location . . . . .	10	Warranty Qualifications . . . . .	23
Before Starting the Engine . . . . .	10	Repair/Replacement Warranty . . . . .	23
Starting the Engine . . . . .	10	Do not return the unit to the place of	
Distance from Cleaning Surface . . . . .	10	purchase . . . . .	23
High Pressure Wash . . . . .	11	Warranty Exclusions . . . . .	23
Thermal Relief Valve (TRV) . . . . .	11	Normal Wear . . . . .	23
Low Pressure Wash . . . . .	12	Installation, Use and Maintenance . . . . .	23
Detergent Use . . . . .	12	Other Exclusions . . . . .	23
System Flush . . . . .	12	Limits of Implied Warranty and	
Depressurize System . . . . .	12	Consequential Damage . . . . .	23
Stopping the Engine . . . . .	13	Contact Information . . . . .	23
Operation at High Altitudes . . . . .	13	Address . . . . .	23
Operating Tips . . . . .	13	Customer Service . . . . .	23
<b>Maintenance and Storage</b> . . . . .	<b>14</b>	Technical Service . . . . .	23
Engine Maintenance . . . . .	14		
Oil . . . . .	14		
Spark Plugs . . . . .	14		
Air Filter . . . . .	14		
Cleaning . . . . .	15		
Adjustments . . . . .	15		

# INTRODUCTION

## Introduction

Congratulations on your purchase of a Champion Power Equipment pressure washer. CPE designs and builds pressure washers to strict specifications. With proper use and maintenance, this pressure washer will bring years of satisfying service.

## Pressure Washer

This unit is a gasoline engine driven pressure washer. It is designed for use in cleaning with or without detergent and is suitable for decks, patios, house siding, vehicles, lawn furniture, barbecue grills, gardening tools and more.

## Accessories

Champion Power Equipment manufactures and sells accessories designed to help you get the most from your purchase. To find out more about our accessories, please visit our web site at:

→ [www.championpowerequipment.com](http://www.championpowerequipment.com)

## This Booklet

Every effort has been made to ensure the accuracy and completeness of the information in this manual. We reserve the right to change, alter and/or improve the product and this document at any time without prior notice.

Record the model and serial numbers as well as date and place of purchase for future reference. Have this information available when ordering parts and when making technical or warranty inquiries.

Champion Power Equipment Support	
1-877-338-0999	
Model Number	
75520	
Serial Number	
Date of Purchase	
Purchase Location	
For <b>Oil Type</b> see 'Add Engine Oil' section. For <b>Fuel Type</b> see 'Add Fuel' section.	

This manual uses the following symbols to help differentiate between different kinds of information. The safety symbol is used with a key word to alert you to potential hazards in operating and owning power equipment.

Follow all safety messages to avoid or reduce the risk of serious injury or death.

 **DANGER**

DANGER indicates an imminently hazardous situation which, if not avoided, **will** result in death or serious injury.

 **WARNING**

WARNING indicates a potentially hazardous situation which, if not avoided, **could** result in death or serious injury.

 **CAUTION**

CAUTION indicates a potentially hazardous situation which, if not avoided, **may** result in minor or moderate injury.

**CAUTION**

CAUTION used without the safety alert symbol indicates a potentially hazardous situation which, if not avoided, **may** result in property damage.

 **NOTE**

If you have questions regarding your pressure washer, we can help. Please call our help line at **1-877-338-0999**

# SAFETY RULES

## WARNING

Read this manual thoroughly before operating your pressure washer. Failure to follow instructions could result in serious injury or death.

## WARNING

The engine exhaust from this product contains chemicals known to the state of California to cause cancer, birth defects, or other reproductive harm.

## DANGER

Engine exhaust contains carbon monoxide, a colorless, odorless, poison gas. Breathing carbon monoxide will cause nausea, dizziness, fainting or death. If you start to feel dizzy or weak, get to fresh air immediately.

Operate pressure washer outdoors only in a well ventilated area.

DO NOT operate the pressure washer inside any building, including garages, basements, crawlspaces and sheds, enclosure or compartment, including the pressure washer compartment of a recreational vehicle.

DO NOT allow exhaust fumes to enter a confined area through windows, doors, vents or other openings.

**DANGER CARBON MONOXIDE**, using a pressure washer indoors **CAN KILL YOU IN MINUTES**.

## DANGER

Rotating parts can entangle hands, feet, hair, clothing and/or accessories.  
Traumatic amputation or severe laceration can result.

Keep hands and feet away from rotating parts.  
Tie up long hair and remove jewelry.  
Operate equipment with guards in place.  
DO NOT wear loose-fitting clothing, dangling drawstrings or items that could become caught.

## WARNING

Sparks can result in fire or electrical shock.

### When servicing the pressure washer:

Disconnect the spark plug wire and place it where it cannot contact the plug.

DO NOT check for spark with the plug removed.

Use only approved spark plug testers.

## WARNING

Running engines produce heat. Severe burns can occur on contact. Combustible material can catch fire on contact.

DO NOT touch hot surfaces.

Avoid contact with hot exhaust gases.

Allow equipment to cool before touching.

Maintain at least three feet of clearance on all sides to ensure adequate cooling.

Maintain at least five feet of clearance from combustible materials.

## WARNING

DO NOT let water in the pump freeze.

See Storage section in the manual for instructions regarding winter storage.

If water has frozen in the pressure washer, thaw the pressure washer in a warm room before starting.

DO NOT pour hot water on or into the pump; internal parts will be damaged and your warranty will be voided.

## WARNING

NEVER spray flammable liquids or use pressure washer in areas containing combustible dust, liquids, or vapor.

NEVER operate this machine in a closed building or in or near an explosive environment.

- DO NOT remove fuel tank cap or fill fuel tank while engine is hot or running (allow engine to cool two minutes before refueling). Always fill the tank slowly.
- Never disconnect the high pressure discharge hose from the machine while the system is pressurized.

** DANGER**

Fuel and fuel vapors are highly flammable and extremely explosive.  
Fire or explosion can cause severe burns or death.  
Unintentional startup can result in entanglement, traumatic amputation or laceration.

**When adding or removing fuel:**

Turn the pressure washer off and let it cool for at least two minutes before removing the fuel cap.  
Loosen the cap slowly to relieve pressure in the tank.  
Only fill or drain fuel outdoors in a well-ventilated area.  
DO NOT pump gas directly into the pressure washer at the gas station. Use an approved container to transfer the fuel to the pressure washer.  
DO NOT overfill the fuel tank.  
Always keep fuel away from sparks, open flames, pilot lights, heat and other sources of ignition.  
DO NOT light or smoke cigarettes.

**When starting the pressure washer:**

DO NOT attempt to start a damaged pressure washer.  
Make certain that the gas cap, air filter, spark plug, fuel lines and exhaust system are properly in place.  
Allow spilled fuel to evaporate fully before attempting to start the engine.  
Make certain that the pressure washer is resting firmly on level ground.

**When operating the pressure washer:**

DO NOT move or tip the pressure washer during operation.  
DO NOT tip the pressure washer or allow fuel or oil to spill.

**When transporting or servicing the pressure washer:**

Make certain that the fuel shutoff valve is in the off position and the fuel tank is empty.  
Disconnect the spark plug wire.

**When storing the pressure washer:**

Store away from sparks, open flames, pilot lights, heat and other sources of ignition.

**CAUTION**

**NEVER** run the unit dry.

Be sure the water supply is completely turned on before operating the unit.

** WARNING**

Rapid retraction of the starter cord will pull hand and arm towards the engine faster than you can let go.  
Unintentional startup can result in entanglement, traumatic amputation or laceration.  
Broken bones, fractures, bruises or sprains could result.

When starting engine, pull the starter cord slowly until resistance is felt and then pull rapidly to avoid kickback.

** DANGER**

Keep clear of nozzle.  
DO NOT point the pressure wand at a person, an animal or yourself.

Always wear safety glasses or goggles and protective equipment (hearing protection, gloves, rubber boots, protective clothing) when operating or performing maintenance.

- Never put hand or fingers over the spray tip while operating the unit.
- Never try to stop or deflect leaks with any body part.
- Always engage the trigger safety latch in the safe position when spraying is stopped even if only for a few moments.

** CAUTION**

Improper treatment or use of the pressure washer can damage it, shorten its life and void your warranty.

Use the pressure washer only for intended uses.  
Operate only on level surfaces.  
DO NOT expose pressure washer to excessive moisture, dust, or dirt.  
DO NOT allow any material to block the cooling slots.  
DO NOT use the pressure washer if:

- Equipment sparks, smokes or emits flames
- Equipment vibrates excessively

# CONTROLS AND FEATURES

Read this owner's manual before operating your pressure washer. Familiarize yourself with the location and function of the controls and features. Save this manual for future reference.

## Pressure Washer

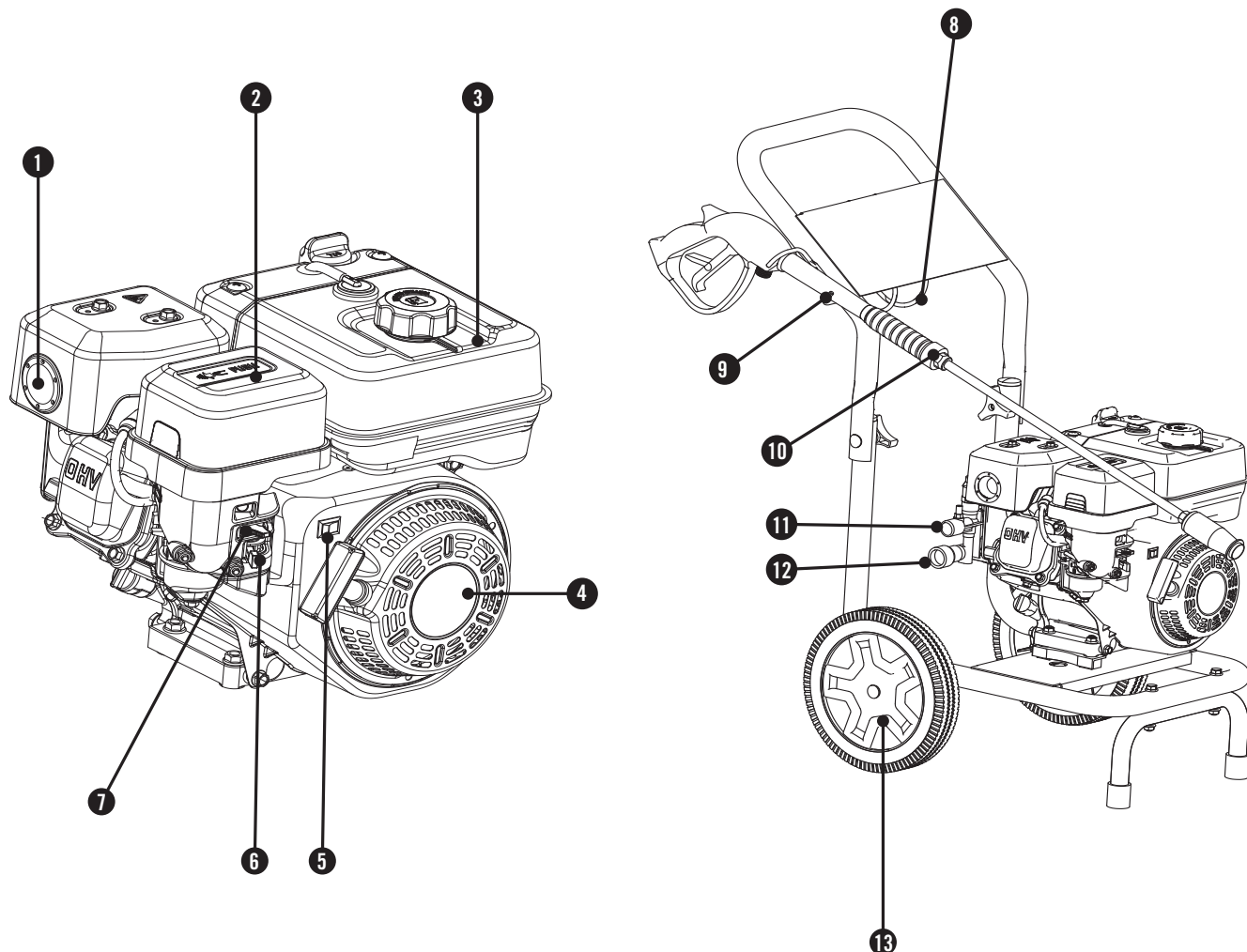

- (1) **Muffler**
- (2) **Air Filter** – Protects the engine by filtering dust and debris from the intake air.
- (3) **Fuel Tank** – 0.53 gal. (2 L)
- (4) **Recoil Starter** – Used to manually start the engine.
- (5) **Engine Switch**
- (6) **Fuel Valve Knob** – Used to turn fuel supply on and off to engine.
- (7) **Choke**
- (8) **High Pressure Hose Hanger** – Used to hold high pressure hose when not in use.
- (9) **Gun Holder** – Used to hold gun when assembled and in use.
- (10) **Gun Assembly** – Gun and High pressure wand for power washing.
- (11) **High Pressure Hose Connection**
- (12) **Garden Hose Connection**
- (13) **10 in. Never Flat Tires**



## Parts Included

Your 75520 Gasoline Powered Pressure Washer ships with the following parts:

### Gun Assembly

- Pressure Gun . . . . . 1
- Wand . . . . . 1
- 25 ft. High Pressure Hose . . . . . 1

### Upper Frame Assembly

- Upper Frame . . . . . 1
- Bolt M5x12 . . . . . 2
- Bolt M5x45 . . . . . 2
- Nut M5 . . . . . 4
- Gun Holder . . . . . 1
- Hose Holder . . . . . 1
- Clamping Knob . . . . . 2
- Contour Bolt M8x55 . . . . . 2

### Wheel Kit

- Wheel 10 in. . . . . 2
- Roll Pin 12x95 . . . . . 2
- Bush Block . . . . . 2
- Clamp B . . . . . 2

### Foot Kit

- Foot . . . . . 1
- Bolt M8x65 . . . . . 2
- Nut M8 . . . . . 2

### Other

- Chemical Inject Hose . . . . . 1
- Oil Funnel . . . . . 1
- Spark Plug Socket . . . . . 1

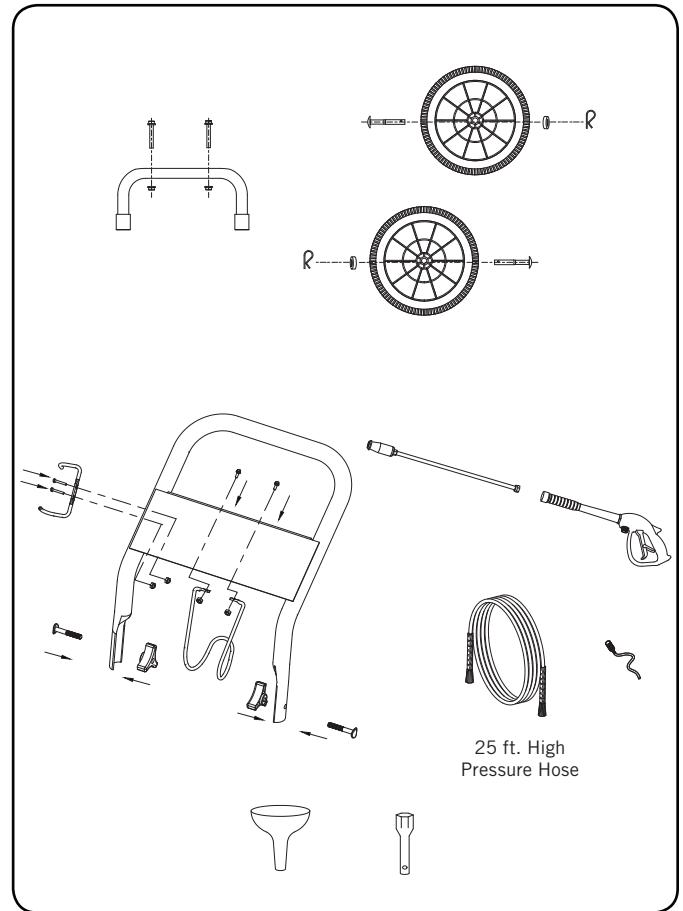

# ASSEMBLY

Your pressure washer requires some assembly. This unit ships from our factory without oil. It must be properly serviced with fuel and oil before operation.

If you have any questions regarding the assembly of your pressure washer, call our help line at 1-877-338-0999. Please have your serial number and model number available.

## Remove the Pressure Washer from the Shipping Carton

1. Set the shipping carton on a solid, flat surface.
2. Remove everything from the carton except the pressure washer.
3. Carefully cut each corner of the box from top to bottom.

## Upper Frame Assembly

1. Line up the upper frame with the bottom frame.
2. Slide the upper frame downward onto the bottom frame, until the holes are lined up. (A)
3. Insert the M8x55 Contour Bolt into the holes and secure it with the Clamping Knob. (B)
4. Repeat steps 1-3 for other bolt and knob.

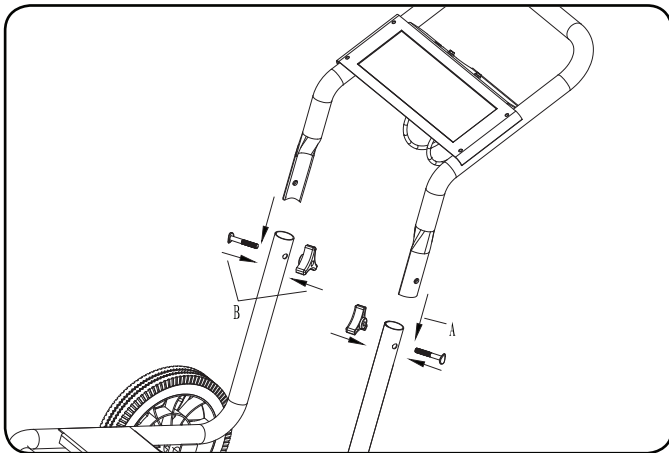

## Wheel Assembly

1. Slide Wheel Roll Pin (#24) through the Wheel (#25) from the outside.
2. Slide Wheel Bush Block (#27) on the Wheel Roll Pin (#24).
3. Insert the Pin through the wheel bracket on the frame (#13).
4. Secure the Pin with Clamp B (#28).
5. Repeat steps 1-4 for second wheel.

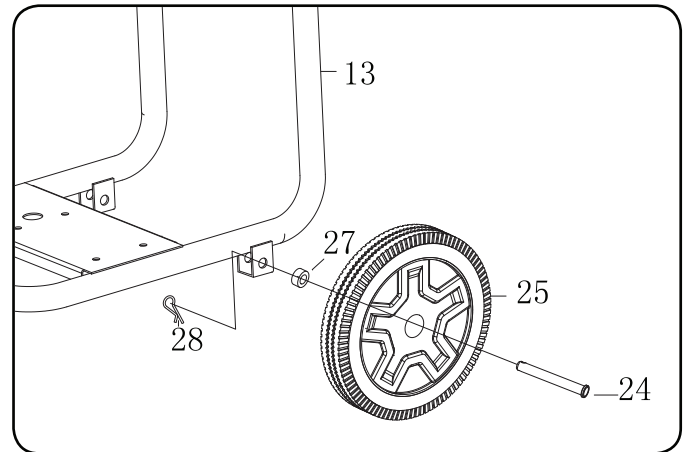

## Support Foot Assembly

1. Align the Support Foot (#30) with the holes in the front of the frame.
2. Insert an M8x65 screw (#26) through each hole from the top.
3. Secure each screw with an M8 nut (#29) from below.

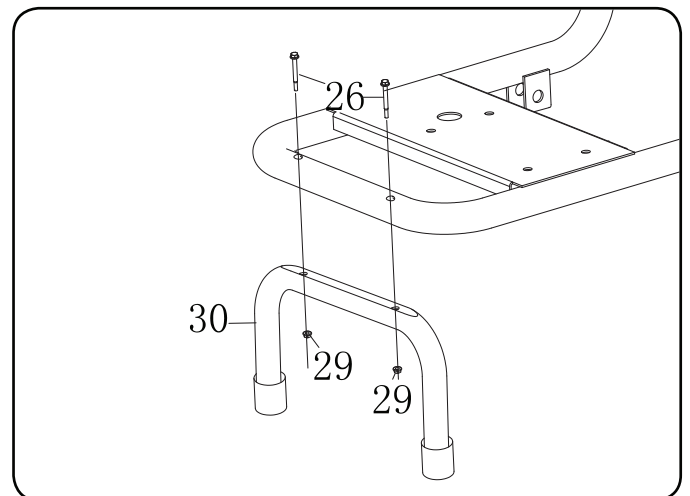

## Add Engine Oil

### CAUTION

DO NOT attempt to crank or start the engine before it has been properly filled with the recommended type and amount of oil. Damage to the pressure washer as a result of failure to follow these instructions will void your warranty.

### NOTE

The recommended oil type is 10W-30 automotive oil.

1. Place the pressure washer on a flat, level surface.

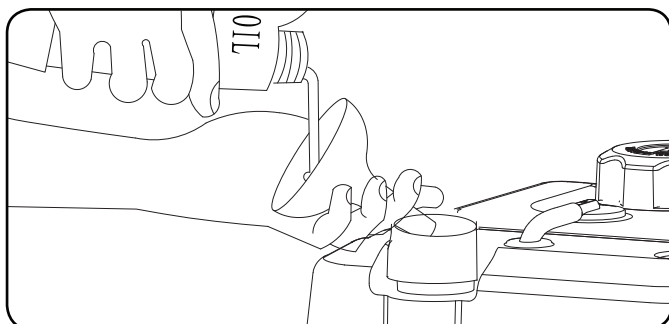

2. Remove oil fill cap/dipstick to add oil.
3. Add up to 0.63 qt. (0.6 L) of oil and replace oil fill cap/dipstick.

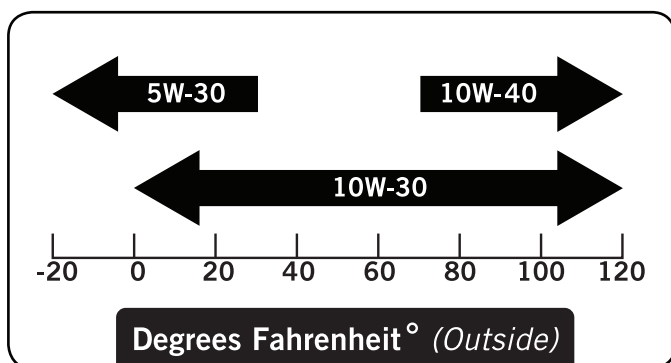

4. Check engine oil level daily and add as needed.

### CAUTION

The engine is equipped with a low oil shut-off and will stop when the oil level in the crankcase falls below the threshold level.

### NOTE

Check oil often during the break-in period. Refer to the Maintenance section for recommended service intervals.

## Add Engine Oil Cont'd.

### NOTE

The engine rotor has a sealed, pre-lubricated ball bearing that requires no additional lubrication for the life of the bearing.

## Add Fuel

1. Use clean, fresh, regular unleaded fuel with a minimum octane rating of 85 and an ethanol content of less than 10% by volume.
2. DO NOT mix oil with fuel.
3. Clean the area around the fuel cap.
4. Remove the fuel cap.
5. Slowly add fuel to the tank. DO NOT OVERFILL. Fuel can expand after filling. A minimum of ¼ in. (0.64 cm) of space left in the tank is required for fuel expansion, more than ¼ in. (0.64 cm) is recommended. Fuel can be forced out of the tank as a result of expansion if it is overfilled, and can affect the stable running condition of the product. When filling the tank, it is recommended to leave enough space for the fuel to expand.

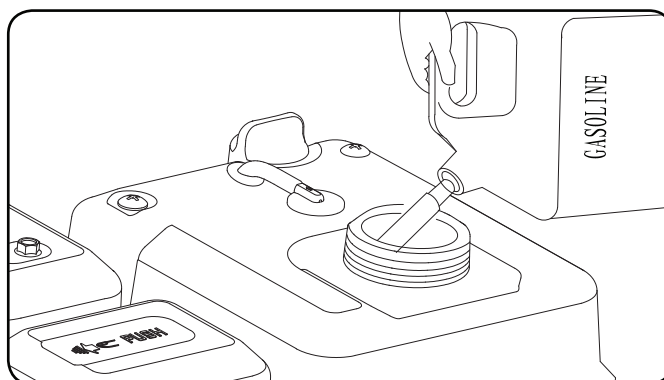

6. Screw on the fuel cap and wipe away any spilled fuel.

### WARNING

Pouring fuel too fast through the fuel screen may result in blow back of fuel at the operator while filling.

# ASSEMBLY

## Add Fuel Cont'd.

### ⚠ CAUTION

Use regular unleaded gasoline with a minimum octane rating of 85.

Do not mix oil and gasoline.  
 Fill tank to approximately  $\frac{1}{4}$  in. (0.64 cm) below the top of the tank to allow for fuel expansion.  
 DO NOT pump gas directly into the pressure washer at the gas station. Use an approved container to transfer the fuel to the pressure washer.  
 DO NOT fill fuel tank indoors.  
 DO NOT fill fuel tank when the engine is running or hot.  
 DO NOT overfill the fuel tank.  
 DO NOT light cigarettes or smoke when filling the fuel tank.

### NOTE

Our engines work well with 10% or less ethanol blend fuels. When using blended fuels there are some issues worth noting:

- Ethanol-gasoline blends can absorb more water than gasoline alone.
- These blends can eventually separate, leaving water or a watery goo in the tank, fuel valve and carburetor.
- With gravity-fed fuel supplies, this compromised fuel can be drawn into the carburetor and cause damage to the engine and/or potential hazards.
- There are only a few suppliers of fuel stabilizer that are formulated to work with ethanol blend fuels.
- Any damages or hazards caused by using improper fuel, improperly stored fuel, and/or improperly formulated stabilizers, are not covered by manufacture's warranty.

It is advisable to always shut off the fuel supply, run the engine to fuel starvation and drain the tank when the equipment is not in use for more than 30 days.

## Attach the Pressure Gun Assembly

1. Attach the wand (A) to the gun (B).
2. Rotate the 22 mm nut (clock wise) until the wand is secure. Tighten connection. DO NOT OVER TIGHTEN.
3. Connect the end of the high pressure hose (C) to the gun inlet. Tighten connection clock wise. DO NOT OVER TIGHTEN.
4. Slide the Quick Connect sleeve towards the gun. Insert quick connect nozzle. Be sure the quick connect sleeve is moved forward to secure the nozzle in place.

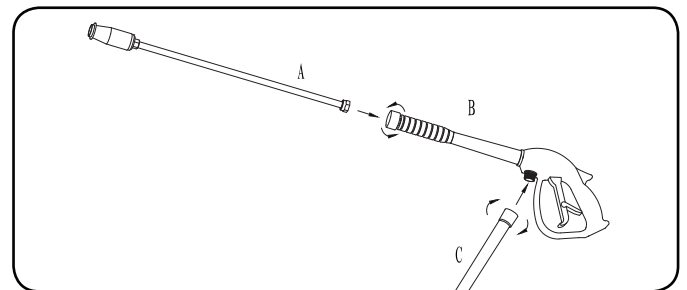

## Connect the High Pressure Hose

Take the end of the High Pressure hose that isn't connected to the gun inlet and insert it into the connection on the pump. Rotate hose end (clock wise) until secure. Tighten connection. DO NOT OVER TIGHTEN.

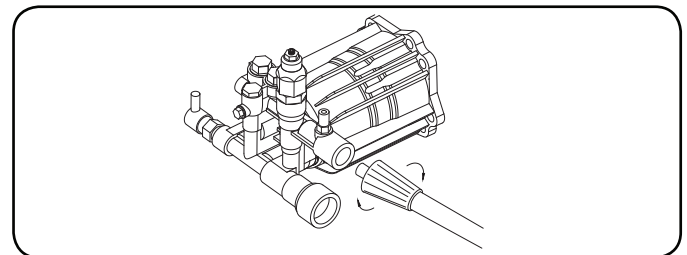

## Connect the Garden Hose

Take the end of the garden hose that isn't connected to the main water supply and connect it to the pump. Rotate the base of the hose connection until secure. Tighten connection. DO NOT OVER TIGHTEN.

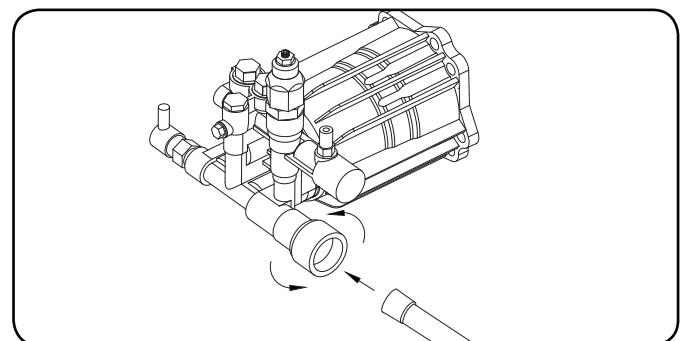

## Pressure Washer Location

This pressure washer must have at least five feet of clearance from combustible material. Leave at least three feet of clearance on all sides of the pressure washer to allow for adequate cooling, maintenance and servicing. Place the pressure washer in a wellventilated area. DO NOT place the pressure washer near vents or intakes where exhaust fumes could be drawn into occupied or confined spaces. Carefully consider wind and air currents when positioning pressure washer.

## Before Starting the Engine

1. Turn the water supply ON.
2. Pull the trigger on the pressure gun to purge all air from the pump and hose. This may take several minutes.
3. Do not start the engine until a steady stream of water is flowing from the nozzle.

### ! CAUTION

Never operate your pressure washer without water.

## Starting the Engine

1. Make certain the pressure washer is on a flat, level surface.
2. Press the engine switch to "ON" position (Item A).
3. Move the fuel valve to the "ON" position (Item B).

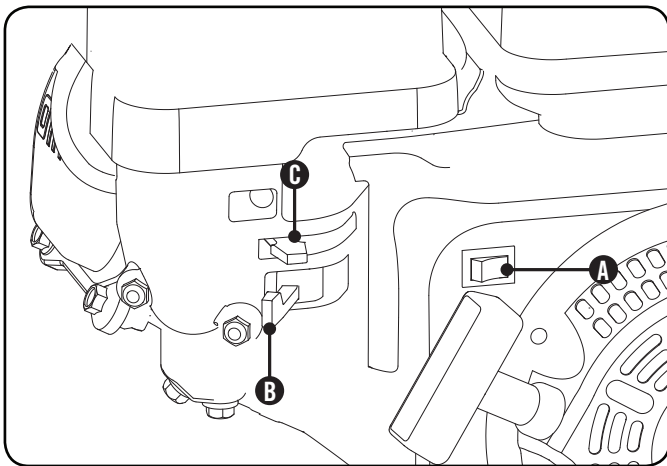

4. Move the choke lever (Item C) to the "Choke" position.
5. Pull the starter cord slowly until resistance is felt and then pull rapidly. **SEE NOTE.**
6. As engine warms up, move the choke lever (Item C) to "Run."

## Starting the Engine Cont'd.

### NOTE

Keep choke lever in "Choke" position for 2 pulls of the recoil starter. After second pull, move choke lever to the "Run" position for up to the next 3 pulls of the recoil starter. Too much choke leads to spark plug fouling/engine flooding due to the lack of incoming air. This will cause the engine not to start.

### NOTE

If the engine does not start after 2 pulls, relieve pump pressure by pulling the trigger on the pressure washer gun.

### NOTE

If the engine starts but does not run make certain that the pressure washer is on a flat, level surface. The engine is equipped with a low oil sensor that will prevent the engine from running when the oil level falls below a critical threshold.

## Distance from Cleaning Surface

The distance between the spray nozzle and the cleaning surface is another factor that affects the impact force of the water. The impact force of the water increases as the nozzle is moved closer to the surface. You can vary the impact force by controlling

1. The nozzle's fan pattern.
  2. The nozzle's angle to the cleaning surface.
  3. The nozzle's distance from the cleaning surface.
- Never use a narrow high impact stream on a surface that is susceptible to damage. Avoid spraying windows with a narrow high impact stream or turbo nozzle. Doing so may break the glass.
1. Before triggering the gun, select a nozzle with a wide fan pattern.
  2. Place the nozzle approximately 4-5 feet away from the cleaning surface. Then hold the nozzle at a 45 degree angle to the cleaning surface. Trigger the gun.
  3. Vary the fan pattern spray angle and the distance to the cleaning surface until optimum cleaning efficiency is achieved without damaging the surface.

# OPERATION

## High Pressure Wash

### ! CAUTION

Always engage the trigger safety latch when the unit is not in use.

The trigger safety latch prevents the gun from being triggered accidentally. Push the latch fully down to engage it.

### CAUTION

The narrow high impact spray can damage some surfaces.

A wide fan pattern distributes the impact of the water over a larger area resulting in excellent cleaning action with reduced risk of surface damage. Clean large surface areas quickly using a wide fan pattern.

## Thermal Relief Valve (TRV)

This pressure washer uses a pump that is equipped with an automatic thermal relief valve. The thermal relief valve will automatically open after approximately 2 minutes passing, without the pulling of the gun trigger, while the engine is running. Running the engine and not pulling the trigger causes the water temperature inside the pump to heat up. When the temperature exceeds 140° F (60° C), or after approximately 2 minutes of non-gun use, the thermal relief valve automatically activates. When the valve is activated, it opens to allow fresh/cool water flow into the pump and hot water to escape. As a result of the valve opening, hot water inside the pump will spray out through the Thermal Relief Valve. When the pump cools, the valve automatically closes.

### ! CAUTION

Water leaving the valve and/or gun after the valve has become activated may be hot. Make sure the pressure washer is in a location that is not sensitive to hot water, and has a clearance space around it of a minimum distance of 3 feet. DO NOT point the gun at any animal, human, or surface to avoid any damage and/or injury caused by hot and/or pressurized water

### NOTE

It is recommended that the inlet water temperature not exceed 104° F (40° C).

## Low Pressure Wash

### Detergent Use

The use of detergents can dramatically reduce cleaning time and assist in the removal of difficult stains. Many detergents are customized for pressure washer use on specific cleaning tasks. Pressure washer detergents are as thick as water. Using thicker detergents – like dish soap – will clog the chemical injection system.

### NOTE

Use only detergents specially formulated for pressure washers.

You can effectively clean surfaces by combining the chemical action of detergents with high pressure rinses. On vertical surfaces, apply the detergent starting at the bottom and work your way upward. This method prevents the detergent from sliding down and causing streaks. Begin high pressure rinsing at the bottom and work your way upward. On particularly tough stains, use a brush in combination with detergents and high pressure rinsing.

### WARNING

NEVER use Bleach in the Detergent Tank. It will damage the pump and void the warranty.

### NOTE

When spraying detergent, the detergent will be diluted 1:12. Approximately 21oz. of detergent will be consumed from the tank for every minute sprayed.

## System Flush

After using detergents, flush the suction system by placing the detergent suction tube into a bucket of clean water.

### WARNING

NEVER turn the water supply off before turning the engine off.

## Depressurize System

To depressurize, turn engine/motor off, turn water supply off and squeeze gun trigger 2-3 times.

### WARNING

NEVER disconnect the high pressure discharge hose from the machine while the system is pressurized.

To reduce the risk of bodily injury or property damage, always follow this procedure whenever spraying is stopped, when work is completed, and before checking or repairing any part of the system.

1. Engage the trigger safety latch.
2. Turn the unit off.
3. Remove the ignition cable from the spark plug.
4. Shut off the water supply.
5. Disengage the trigger safety latch and trigger the gun to relieve pressure.
6. Re-engage the trigger safety latch.
7. Before overnight storage, long term storage, or transporting unit, disconnect the water supply and turn off the fuel supply valve.

# OPERATION

## Stopping the Engine

1. Move the Fuel Valve to the “OFF” position.
2. Let the engine run until fuel starvation has stopped the engine. This usually takes a few minutes.
3. Press the engine switch to the “OFF” position.
4. Depressurize system.
5. Turn off and unplug all hoses. Never start or stop the pressure washer unless the water supply is turned on.

**Important:** Always ensure that the Fuel Valve and the Engine Switch are in the “OFF” position when the engine is not in use.

### NOTE

If the engine will not be used for a period of two (2) weeks or longer, please see the Storage section for proper engine and fuel storage.

## Operation at High Altitude

The density of air at high altitude is lower than at sea level. Engine power is reduced as the air mass and air-fuel ratio decrease. Engine power and output will be reduced approximately 3½% for every 1000 feet of elevation above sea level. This is a natural trend and cannot be changed by adjusting the engine.

## Operating Tips

### CAUTION

Never operate your pressure washer without water.

### CAUTION

Never connect your pressure washer to a hot water supply.

Connecting your pressure washer to a hot water source will significantly reduce the life of the pump and will void the warranty.

### CAUTION

Running the unit for more than one minute without spraying water causes heat to build up in the pump.

In the event that the pump gets too hot, a thermal relief valve will open to release the hot water. Running the unit without spraying water can damage pump components and will void the warranty.



The owner/operator is responsible for all periodic maintenance.

### **WARNING**

Never operate a damaged or defective pressure washer.

### **WARNING**

Improper maintenance will void your warranty.

### **NOTE**

Maintenance, replacement, or repair of emission control devices and systems may be performed by any non-road engine repair establishment or individual.

Complete all scheduled maintenance in a timely manner. Correct any issue before operating the pressure washer.

### **NOTE**

For service or parts assistance, contact our help line at **1-877-338-0999**

## Engine Maintenance

To prevent accidental starting, remove and ground spark plug wire before performing any service.

### Oil

Change oil when the engine is warm. Refer to the oil specification to select the proper grade of oil for your operating environment.

1. Remove the oil drain plug with a 12 mm socket and extension.
2. Allow the oil to drain completely.
3. Replace the drain plug.
4. Remove oil fill cap/dipstick to add oil.
5. Add up to 0.63 qt. (0.6 L) of oil and replace oil fill cap/dipstick.
6. Dispose of used oil at an approved waste management facility.

### **NOTE**

Once oil has been added, a visual check should show oil about 1-2 threads from running out of the fill hole. If using the dipstick to check oil level, **DO NOT** screw in the dipstick while checking.

### Oil Cont'd.

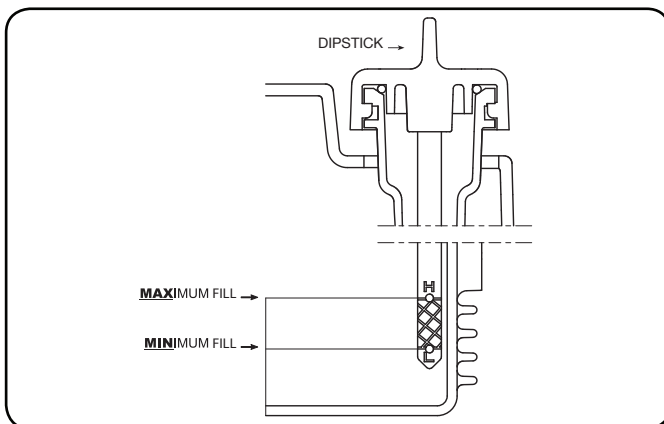

### Spark Plugs

1. Remove the spark plug cable from the spark plug.
2. Use the spark plug tool that shipped with your pressure washer to remove the plug.
3. Inspect the electrode on the plug. It must be clean and not worn to produce the spark required for ignition.
4. Make certain the spark plug gap is 0.6 - 0.8 mm (0.024 - 0.031 in.).

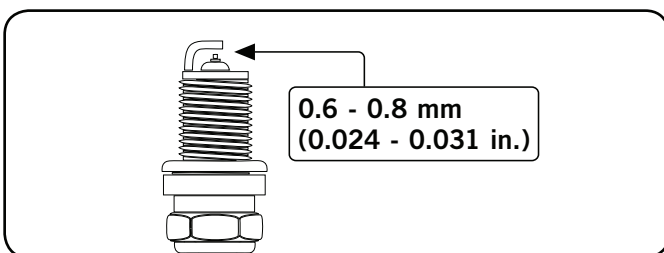

5. Refer to the spark plug recommendation chart when replacing the plug.
6. Carefully thread the plug into the engine.
7. Use the spark plug tool to firmly install the plug.
8. Attach the spark plug wire to the plug.

### Air Filter

1. Using your fingers, press and slide the top of the air filter housing to remove.
2. Remove the plastic outer casing.
3. Remove the foam element.
4. Wash in liquid detergent and water. Squeeze thoroughly dry in a clean cloth.
5. Saturate in clean engine oil.
6. Squeeze in a clean, absorbent cloth to remove all excess oil.
7. Place the filter in the assembly.
8. Reattach the air filter cover.

# MAINTENANCE AND STORAGE

## Cleaning

### ! CAUTION

DO NOT spray engine with water.

Water can contaminate the fuel system.

Use a damp cloth to clean exterior surfaces of the engine.  
 Use a soft bristle brush to remove dirt and oil.  
 Use an air compressor (25 PSI) to clear dirt and debris from the engine.

## Adjustments

CPE recommends that you contact our service line at **1-877-338-0999** for all other service and/or adjustment needs.

## Maintenance Schedule

Follow the service intervals indicated in the schedule below.

Service your pressure washer more frequently when operating in adverse conditions.

Contact our help line at **1-877-338-0999** to locate the nearest Champion Power Equipment certified service dealer for your maintenance needs.

Every time of use or daily	
	Check engine oil levels
	Clean around air intake and muffler
	Check air filter
First 5 Hours	
	Change engine oil
Every 25 Hours or per 1 month	
	Change engine oil
	Clean air filter
Every 50 hours or per 6 months	
	Clean and adjust spark plug(s)
	Check cooling fan
Every 100 hours or per 1 year	
	Clean spark arrester (optional)
	Check/adjust valve clearance *
	Clean fuel tank and filter *
Every 200 hours	
	Clean combustion chamber*
Every 200 hours or per 2 years	
	Check/replace fuel line
	Change spark plug (s)

\*To be performed by knowledgeable, experienced owners or Champion Power Equipment certified dealers.

## Pressure Washer Maintenance

Make certain that the pressure washer is kept clean and stored properly. Only operate the unit on a flat, level surface in a clean, dry operating environment. DO NOT expose the unit to extreme conditions, excessive dust, dirt, moisture or corrosive vapors.

### ! CAUTION

DO NOT use a garden hose to clean the pressure washer.

Use a damp cloth to clean exterior surfaces of the pressure washer.  
 Use a soft bristle brush to remove dirt and oil.  
 Use an air compressor (25 PSI) to clear dirt and debris from the pressure washer.  
 Inspect all air vents and cooling slots to ensure that they are clean and unobstructed.

## Cleaning Spray Nozzle

1. Detach the wand from the gun. (A)
2. Twist the adjustable spray nozzle head at the end of the wand, until the inside tabs are in the open position. (B)
3. Use a small wire rod (paper clip) to loosen up any particles in the adjustable spray nozzle head and flush with water. (B)

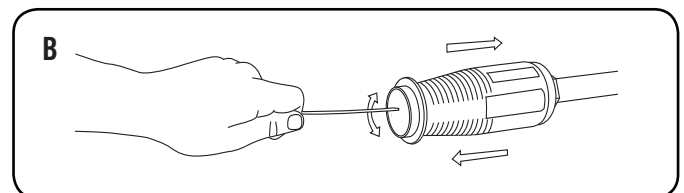
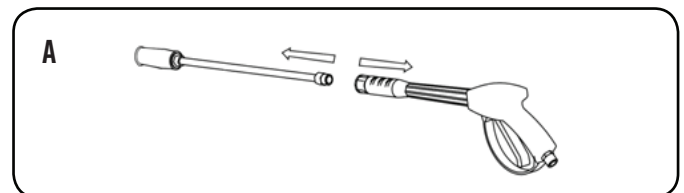

## Storage

For short and long-term storage, please follow these guidelines.

### NOTE

Engine switch should be in the "OFF" position while pulling the recoil cord, and performing storage maintenance steps.

## Engine Stored for Less than 30 Days

1. Allow the engine to cool completely before storage.
2. Clean engine according to the Maintenance section.
3. To extend the fuel storage life add a properly formulated fuel stabilizer to the tank.
4. Ensure the fuel valve is in the "OFF" position.

### Engine Stored for Over 30 Days

1. Add a properly formulated fuel stabilizer to the tank.
2. Run the engine for a few minutes so the treated fuel cycles through the fuel system and carburetor.
3. Turn the fuel valve to the "Off" position.
4. Let the engine run until fuel starvation has stopped the engine. This usually takes a few minutes.
5. The engine needs to cool completely before cleaning and storage.
6. Clean the engine according to the maintenance section.
7. Change the oil.
8. Remove the spark plug and pour about 1/2 ounce of oil into the cylinder. Crank the engine slowly to distribute the oil and lubricate the cylinder.
9. Reattach the spark plug.

### DANGER

Engine exhaust contains odorless and colourless carbon monoxide gas.

To avoid accidental or unintended ignition of the product during periods of storage, the following precautions should be followed:

- When **storing the pressure washer for short or long periods of time** make sure that the Engine Switch and the Fuel Valve are set in the **OFF** position.

### NOTE

Our engines work well with 10% or less ethanol blend fuels. When using blended fuels there are some issues worth noting:

- Ethanol-gasoline blends can absorb more water than gasoline alone.
- These blends can eventually separate, leaving water or a watery goo in the tank, fuel valve and carburetor.
- With gravity-fed fuel supplies, this compromised fuel can be drawn into the carburetor and cause damage to the engine and/or potential hazards.
- There are only a few suppliers of fuel stabilizer that are formulated to work with ethanol blend fuels.
- Any damages or hazards caused by using improper fuel, improperly stored fuel, and/or improperly formulated stabilizers, are not covered by manufacture's warranty.

It is advisable to always shut off the fuel supply, run the engine to fuel starvation and drain the tank when the equipment is not in use for more than 30 days.

### Pressure Washer Storage

1. Allow the pressure washer to cool completely before storage.
2. Turn off the fuel supply at the fuel valve.
3. Clean the pressure washer according to the instructions in the Maintenance section.
4. Store the unit in a clean, dry area out of direct sunlight.

### WARNING

Never store the pressure washer inside or next to appliances where there is a source of heat or open flame, spark or pilot light because they can ignite gasoline vapors.

DO NOT store a pressure washer near fertilizer or any corrosive material.

Even with an empty gas tank, gasoline vapors could ignite.

### Winter Storage

Protect your pressure washer parts from freezing.

1. Apply all storage instructions from previous sections.
2. Make sure pressure washer hose is free of all water before storing for winter.
3. In order to prevent the pump from freezing you will need to insert RV antifreeze.
4. You will need approximately 6 ounces of RV Antifreeze, a funnel, and approximately 30 cm (12 in.) of garden hose or equivalent. See diagram below.

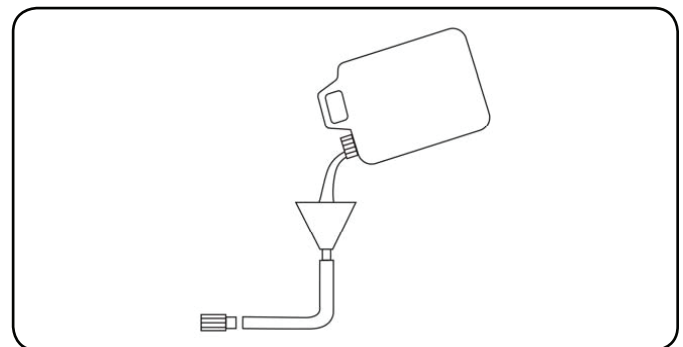

5. Pour the antifreeze into the funnel, then pull on the engine recoil starter to create suction in the pump housing. Pull the recoil several times until antifreeze comes out of the pump outlet.

# SPECIFICATIONS

## Engine Specifications

- Model ..... 170F
- Displacement ..... 208cc
- Type ..... 4-Stroke OHV
- Start Type ..... Recoil

## Pressure Washer Specifications

- Model ..... 75520
- Max Pressure ..... 2650 PSI
- Max Water Temperature ..... 104°F (40°C)
- Flow Capacity ..... 2.3 GPM
- Fuel Capacity ..... 0.53 gal. (2 L)
- Gross Weight ..... 66.1 lbs. (30 kg)
- Net Weight ..... 61.7 lbs. (28 kg)
- Height ..... 35.4 inches (90 cm)
- Width ..... 19.7 inches (50 cm)
- Length ..... 29.9 inches (76 cm)

## Fuel

Fuel capacity is 0.53 gal. (2 L). Use regular unleaded gasoline with a minimum octane rating of 85 and an ethanol content of less than 10% by volume.

## Oil

Use 10W-30 automotive oil.

Oil capacity is up to 0.63 qt. (0.6 L).

Please reference the following chart for recommended oil types for use in the pressure washer.

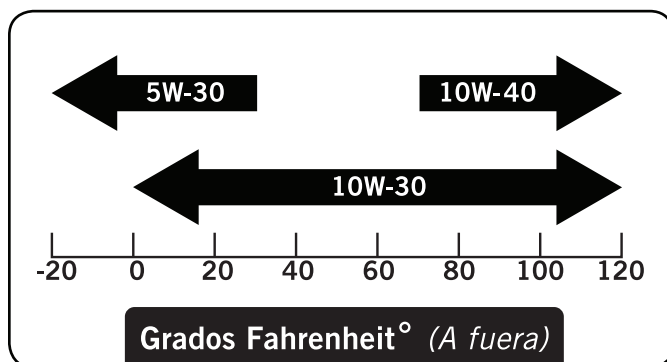

## Spark Plugs

**OEM spark plug:** NHSP F6RTC

**Replacement spark plug:** NGK BPR6ES or equivalent  
Make certain the spark plug gap is 0.6 - 0.8 mm or (0.024 - 0.031 in.).

## Maintenance Valve Clearance

- Intake: 0.10 – 0.15 mm (0.004 – 0.006 in.)
  - Exhaust: 0.15 – 0.20 mm (0.006 – 0.008 in.)
- Note: Tech bulletin regarding the valve adjustment procedure is on [www.championpowerequipment.com](http://www.championpowerequipment.com).

Problem	Cause	Solution
Pressure washer will not start	No fuel	Add fuel
	Faulty spark plug	Replace spark plug
Pressure washer will not start; Pressure washer starts but runs roughly	Low oil level	Fill crankcase to the proper level Place pressure washer on a flat, level surface
	Choke in the wrong position	Adjust choke
	Spark plug wire loose	Attach wire to spark plug
Pressure washer gallops	Engine governor defective	Contact the help line
Unit does not reach high pressure	Water supply is restricted	Check hoses for leaks, blockage, kinks
	Garden hose is too small	Replace with 5/8 in. garden hose or larger
	Garden hose inlet filter is clogged	Remove garden hose, clean filter and rinse out
	Not enough inlet water	Turn garden hose water on full force
Spray pressure varies from high to low	Poor inlet water supply	Turn garden hose water on full force. Check hose for leaks, blockage, or kinks
	Garden hose inlet filter is clogged	Remove garden hose, clean filter and rinse out
	Spray nozzle is obstructed	Remove particles with small wire rod (see maintenance section in manual)
	Pump is sucking air	Check all hoses and fittings, make sure they are securely tightened down and fastened. Turn off engine and purge pump by squeezing trigger gun until a steady stream of water flows
Detergent wash is not functioning properly	Detergent is too thick	Dilute detergent
	Wand is on high pressure setting	Detergent only works on a low pressure setting
	Detergent hose is not connected to the pump housing	Check connection. See diagram on Page 10
	Spray nozzle is obstructed	Clean nozzle and remove debris
	Filter on detergent hose is clogged	Clean with warm water or replace
	Chemical Injector valve (inside pump) partially blocked or stuck	Quickly pull and release the gun trigger 4-5 time to clear the chemical injector valve
Garden hose connection leaks	Loose fittings	Tighten
	Missing/worn-out rubber washer	Replace rubber washer
Spray wand leaks	Spray wand not properly attached	Tighten all connections
Can't Pull Recoil	Pump will build pressure with each pull.	Pull gun trigger after 2 pulls of recoil, to release pump pressure.

### For further technical support:

#### Technical Service

Mon – Fri 8:30 AM – 5:00 PM (PST/PDT)

Toll Free: 1-877-338-0999

tech@championpowerequipment.com

# SPECIFICATIONS

## Parts Diagram

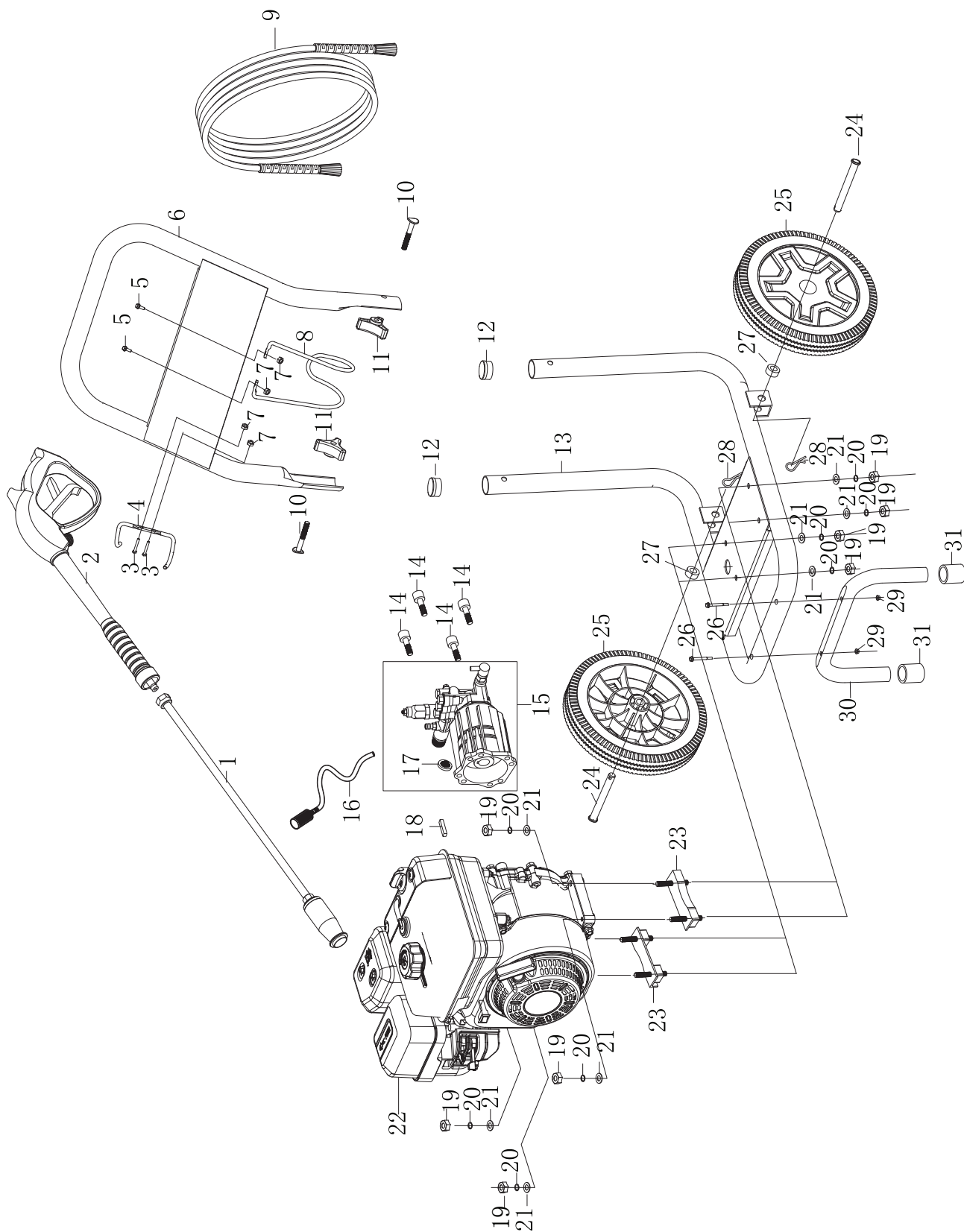

#	Part Number	Description	Qty
1	TR4012-9999-0000	Wand assembly (With Adjustable Nozzle)	1
2	TR4011-9999-0000	Gun Assembly	1
3	B057820005004570B	Bolt M5×45/GB5782/Blue-White Tinted	2
4	TR4010-Z4J-00006X	Gun Hook	1
5	B057890005001270B	Bolt M5×12/GB5789/Blue-White zinted	2
6	TR4060-H76-00006X	Upper Frame Assembly	1
7	B008890005000000B	Nut M5/GB889/Blue-White Tinted	4
8	TR4007-H76-00006X	Hose Hook	1
9	TR3020-H76-0000	Hose	1
10	TR4006-Z4J-0000	Bolt M8×55/Blue-White zinted	2
11	TC2100-C38-0001	Lock Nut	2
12	TR4009-Z4J-0000	Rubber Cap	2
13	TR4050-H76-00006X	Lower Frame Assembly	1
14	TR102B-H76-0000	Bolt 5/16-24×20UNF/Blue-White Tinted	4
15	TR1000-9999-0900	Pump/RMV 2.2G24	1
16	00017-9999-0100	Siphon Hose 1.2m With Filter	1
17	TR1046-Z4J-0000	Inlet Filter	1
18	91606-0350475475B	Flat Key 4.75×4.75×35/B Type	1
19	B061700008000000B	Nut M8/GB6170/Blue-White Tinted	8
20	B000930008000000B	Lock Washer 8	8
21	B000970208000000B	Flat Washer 8/GB97.2/Blue-White Tinted	8
22	10001-Z4A-ZC7X001	Engine Complete	1
23	TR4013-H76-0000	Absorbing Pad	2
24	TR4032-H76-0000	Wheel Roll Pin	2
25	TD4014-Z63-0000	10" Wheel 10x1.75(Hub grey)	2
26	B057890008006570B	Bolt M8×65/GB5789/Blue-White Tinted	2
27	TR4031-H76-0000	Wheel Bushing	2
28	TWC117-C27-0002	Clamp B	2
29	B008890008000000B	Nut M8/GB889/Blue-White Tinted	2
30	TR4070-H76-01006X	Foot	1
31	TR4014-H76-0000	Foot Rubber Pad	2



# SPECIFICATIONS

## Engine Parts Diagram

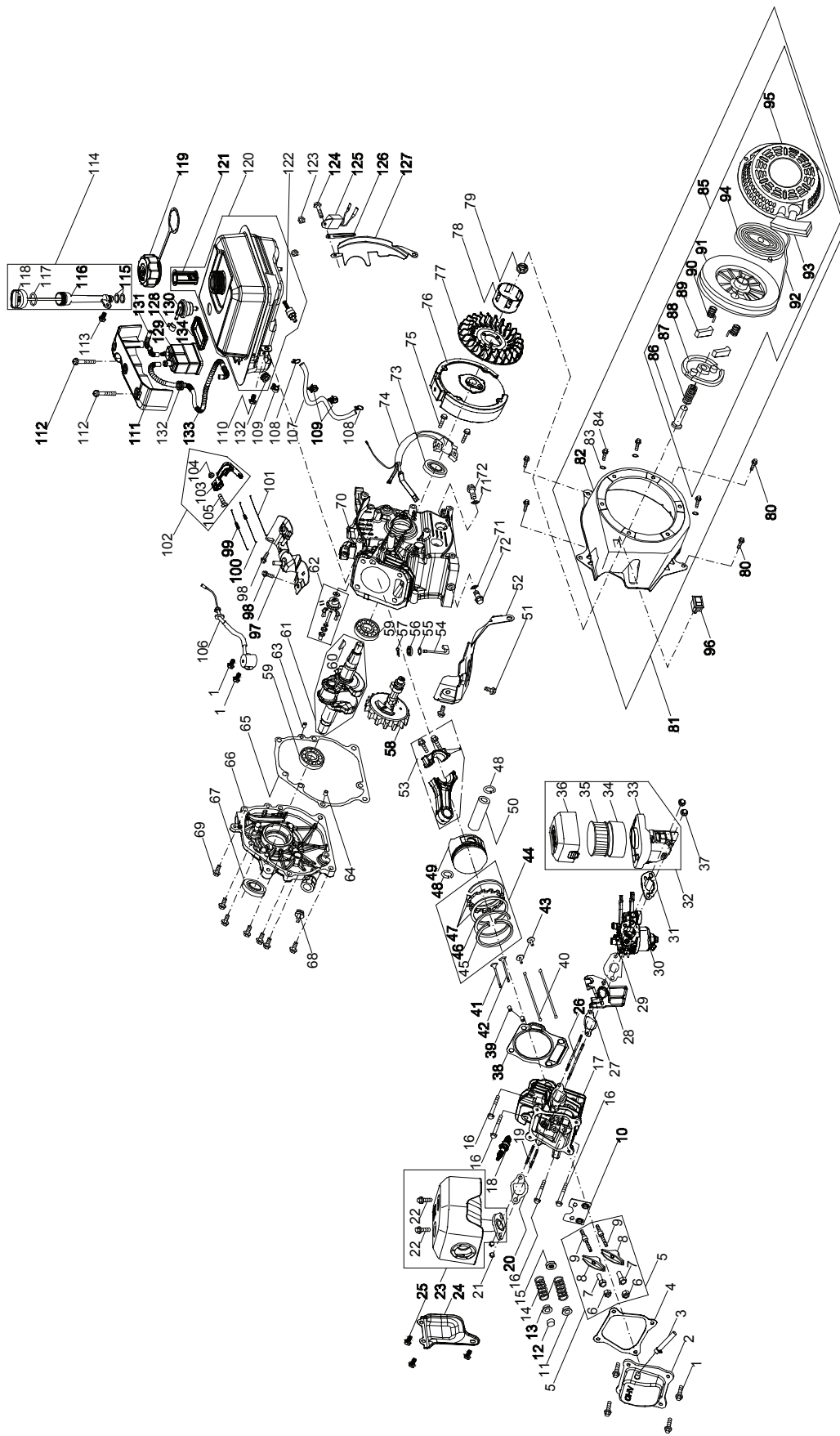



#	Part Number	Description	Qty
1	B057890006001670B	BOLT M6x16	6
2	11221-LC90-0500	VALVE COVER	1
3	12104-KB01-0200	BREATHER HOSE ASSEMBLY	1
4	90229-KB01-0400	VALVE COVER GASKET	1
5	15400-LC90-0001	ROCKER ARM ASSEMBLY	2
6	15414-KB01-0000	NUT PIVOT LOCKING	2
7	15403-KB01-0000	ADJUSTING NUT ,VALVE	2
8	15401-LC90-0001	ROCKER ARM	2
9	15415-KB01-0000	BOLT PIVOT	2
10	15406-KB01-0000	PUSH ROD GUIDE	1
11	15711-KB01-0000	VALVE SPRING RETAINER (INTAKE)	1
12	15713-KB01-0000	EXHAUST LASH CAP	1
13	15712-KB01-0000	VALVE SPRING RETAINER (EXHAUST)	1
14	15703-KB01-0000	VALVE SPRING	2
15	1572B-JD45-0000	VALVE SEAL (INTAKE)	1
16	1122R-LC90-0000	BOLT M8x60	4
17	1122B-LC90-0300	CYLINDER HEAD	1
18	81300-KB01-0400	SPARK PLUG/F6RTC	1
19	91138-KB03-0000	STUD M8x36	2
20	18066-LC90-0000	EXHAUST PIPE GASKET	1
21	B061700008000000B	NUT M8	2
22	B0578900060010700	BOLT M6x10	2
23	18000-LZ4A-0000	MUFFLER ASSEMBLY	1
24	18016-LZ4A-0000	EXHAUST PIPE GUARD	1
25	B057890006001070H	BOLT M6x10	3
26	91127-KB01-0000	STUD M6x110	2
27	17107-LC90-0100	CARBURETOR INSULATOR GASKET	1
28	17112-KB01-0000	CARBURETOR INSULATOR	1
29	17182-KB01-0300	CARBURETOR GASKET	1
30	17100-LC90-1800	CARBURETOR ASSEMBLY	1
31	17113-KB01-0000	CARBURETOR GASKET PLATE	1
32	16100-LZ4A-0100	AIR CLEANER ASSEMBLY	1
33	16180-LZ4A-0100	AIR CLEANER HOUSING	1
34	16104-IC77-0000	SPONGE FILTER	1
35	16101-IC77-0000	AIR CLEANER FILTER ASSEMBLY	1
36	16105-LZ4A-0000	AIR CLEANER COVER	1
37	B061770106000060B-1	NUT M6	2
38	9022B-LC90-0200	GASKET CYLINDER HEAD	1
39	91521-10001600000	DOWEL PIN 10x16	2
40	15321-LC90-0000	PUSH ROD	2
41	15702-LC90-0000	EXHAUST VALVE	1
42	15701-KC67-0000	INTAKE VALVE	1
43	15002-LC90-0000	TAPPET	2
44	1310A-LZ4A-0000	PISTON RING SET	1
45	13103-LZ4A-0000	1ST PISTON RING	1
46	13104-LZ4A-0000	2ND PISTON RING	1
47	13120-LZ4A-0000	OIL RING	1
48	13105-KB01-0000	PISTON PIN SNAP RING	2
49	13101-LC90-0100	PISTON	1
50	13102-LC90-0000	PISTON PIN	1
51	B057890006001270B	BOLT M6x12	2
52	19113-LZ4A-00000B	AIR SHIELD	1
53	13220-LC90-0000	CONNECTING ROD ASSEMBLY	1
54	24605-LC90-0000	GOVERNOR ARM SHAFT	1
55	90101-10052000190	WASHER 5.2x1.9	1
56	T1105006001100400	GOVERNOR SEAL	1
57	24606-KB01-0000	COTTER PIN	1
58	15100-LC90-0000	CAMSHAFT ASSEMBLY	1
59	92102-00000006205	RADIAL BALL BEARING 6205	2
60	91601-IB84-0000	WOODRUFF KEY	1
61	13230-LC90-1400	CRANKSHAFT ASSEMBLY	1
62	24620-LC90-0100	GOVERNOR GEAR/SHAFT ASSEMBLY	1
63	91521-07001400000	DOWEL PIN 7x14	1
64	91521-09001400000	DOWEL PIN 9x14	1
65	90208-LC90-0100	CRANKCASE COVER GASKET	1
66	12301-LC90-0002	CRANKCASE COVER	1
67	T1107025004125600	OIL SEAL 25x 41.25x6	1
68	14311-LC90-0000	DIPSTICK ASSEMBLY	1

#	Part Number	Description	Qty
69	B057890008003270B	BOLT M8x32	7
70	12007-LG10-0300	CRANKCASE	1
71	91302-91001516000	WASHER	2
72	91103-KB01-0000	OIL DRAIN PLUG	2
73	T1105025004125600	OIL SEAL 25x 41.25x6	1
74	81200-LD29-0200	IGNITION COIL ASSEMBLY	1
75	B057890006002570B	BOLT M6x25	2
76	82150-LC90-1000	FLYWHEEL	1
77	19102-KB01-0100	COOLING FAN	1
78	21520-KB01-0700	STARTER CUP	1
79	B061770F14000070B	NUT SPECIAL M14x1.5	1
80	B057890006001270B	BOLT M6x12	4
81	21500-LZ4A-0200CK	RECOIL HOUSING ASSEMBLY	1
82	21530-LZ4A-0000CK	BLOWER HOUSING	1
83	B000950006000000B	GASKET 6	3
84	B166740006001070B	BOLT M6x10	3
85	21510-LC90-14006X	RECOIL STARTER	1
86	21521-KB01-0000	ALIGNMENT BOLT	1
87	21518-KB01-0000	SPRING	1
88	21513-KB01-0000	GUIDE PLATE	1
89	21512-KB01-0000	STARTER PAWL	2
90	21515-KB01-0000	RETURN SPRING, STARTER PAWL	2
91	21511-KB01-0000	STARTER REEL	1
92	21517-KB01-0100	RECOIL SPRING	1
93	21516-IB84-0000	STARTER HANDLE	1
94	21514-LC90-0100	STARTER ROPE	1
95	21519-LC90-07006X	BLOWER HOUSING	1
96	72380-IB84-0200	IGNITION SWITCH	1
97	24610-KB03-0500	PRIMER BRACKET	1
98	B057870006001270B	BOLT M6x12	2
99	24602-LC90-0600	GOVERNOR SPRING	1
100	24603-KB01-0000	THROTTLE LINKAGE SPRING	1
101	24604-KB01-0000	THROTTLE LINKAGE	1
102	24640-LC90-0000	GOVERNOR ARM ASSEMBLY	1
103	24607-LC90-0000	GOVERNOR ARM	1
104	B061770106000060B-1	NUT M6	1
105	91121-1060-02120B	GOVERNOR ARM BOLT	1
106	87400-LC90-0100	OIL SENSOR	1
107	T2999404000800310	FUEL HOSE	1
108	17020-KB01-0000	FUEL HOSE CLAMP	2
109	10061-LZ4A-0000	WIRE CLAMP	3
110	B057890006001270B	BOLT M6x12	1
111	14304-LZ4A-0100	DIPSTICK DECORATION COVER	1
112	24681-LC90-0000	BOLT	2
113	B057890006001270B	BOLT M6x12	1
114	14301-LC90-0500MV	DIPSTICK ASSEMBLY	1
115	90101-10155000150	OIL FILL TUBE O-RING	2
116	14313-LC90-0100	OIL FILL TUBE	1
117	90101-10210000277	OIL FILL TUBE O-RING	1
118	14312-LC90-0100MV	OIL FILLER PLUG	1
119	61120-JC79-0400	CAP COMP,FUEL FELLER	1
120	61100-LZ4A-01006X	FUEL TANK ASSEMBLY	1
121	61137-LC90-0300	FUEL FILTER	1
122	61195-KB01-0000	FUEL TANK NIPPLE	1
123	B061770106000060B	NUT M6	2
124	B057890006002070B	BOLT M6x20	1
125	87420-KB01-0000	ISOLATORS	1
126	10008-9999-0100	LINE CARDS	1
127	19112-LC90-0100	BLOWER HOUSING SHIELD	1
128	17020-NG04-0300	CLAMP	1
129	6114D-LC90-0000	CANISTER	1
130	6114M-LC90-0000	CHECK VALVE	1
131	T2999904000800080	COMPOSITE TUBING	1
132	61182-QD03-0000	RUBBER PAD	2
133	61101-LZ4A-0000	COMPOSITE TUBING	1
134	6114Q-LZ4A-0000	RUBBER SLEEVE	1

# WARRANTY

## WARRANTY

### CHAMPION POWER EQUIPMENT 1 YEAR LIMITED WARRANTY

Effective September 1, 2006. Replaces all undated warranties and all warranties dated before September 1, 2006.

### Warranty Qualifications

Champion Power Equipment (CPE) will register this warranty upon receipt of your Warranty Registration Card and a copy of your sales receipt from one of CPE's retail locations as proof of purchase.

Please submit your warranty registration and your proof of purchase within ten (10) days of the date of purchase.

### Repair/Replacement Warranty

CPE warrants to the original purchaser that the mechanical and electrical components will be free of defects in material and workmanship for a period of one (1) year from the original date of purchase (90 days for commercial & industrial use). Transportation charges on product submitted for repair or replacement under this warranty are the sole responsibility of the purchaser.

This warranty only applies to the original purchaser and is not transferable.

### Do Not Return The Unit To The Place Of Purchase

Contact CPE's Technical Service and CPE will troubleshoot any issue via phone or e-mail. If the problem is not corrected by this method, CPE will, at its option, authorize evaluation, repair or replacement of the defective part or component at a CPE Service Center. CPE will provide you with a case number for warranty service. Please keep it for future reference. Repairs or replacements without prior authorization, or at an unauthorized repair facility, will not be covered by this warranty.

### Warranty Exclusions

This warranty does not cover the following repairs and equipment:

#### Normal Wear

Pressure washers need periodic parts and service to perform well. This warranty does not cover repair when normal use has exhausted the life of a part or the equipment as a whole.

#### Installation, Use and Maintenance

This warranty will not apply to parts and/or labor if this pressure washer is deemed to have been misused, neglected, involved in an accident, abused, loaded beyond the pressure washer's limits, modified, installed improperly or connected incorrectly to any water supply.

#### Installation, Use and Maintenance Cont'd.

Normal maintenance such as spark plugs, air filters, adjustments, fuel system cleaning and obstruction due to buildup is not covered by this warranty.

#### Other Exclusions

This warranty excludes:

- Cosmetic defects such as paint, decals, etc.
- Wear items such as filter elements, o-rings, etc.
- Accessory parts such as starting batteries, and storage covers.
- Failures due to acts of God and other force majeure events beyond the manufacturer's control.
- Problems cause by parts that are not original Champion Power Equipment parts.

#### Limits of Implied Warranty and Consequential Damage

Champion Power Equipment disclaims any obligation to cover any loss of time, use of this product, freight, or any incidental or consequential claim by anyone from using this pressure washer. THIS WARRANTY IS IN LIEU OF ALL OTHER WARRANTIES, EXPRESS OR IMPLIED, INCLUDING WARRANTIES OF MERCHANTABILITY OR FITNESS FOR A PARTICULAR PURPOSE.

A unit provided as an exchange will be subject to the warranty of the original unit. The length of the warranty governing the exchanged unit will remain calculated by reference to the purchase date of the original unit.

This warranty gives you certain legal rights which may change from state to state. Your state may also have other rights you may be entitled to that are not listed within this warranty.

### Contact Information

#### Address

Champion Power Equipment, Inc.  
Customer Service  
10006 Santa Fe Springs Rd.  
Santa Fe Springs, CA 90670  
www.championpowerequipment.com

#### Customer Service

Mon – Fri 8:30 AM – 5:00 PM (PST/PDT)  
Toll Free: 1-877-338-0999  
info@championpowerequipment.com  
Fax no.: 1 (562) 236-9429

#### Technical Service

Mon – Fri 8:30 AM – 5:00 PM (PST/PDT)  
Toll Free: 1-877-338-0999  
tech@championpowerequipment.com

**Champion Power Equipment, Inc. (CPE),  
The United States Environment Protection Agency (U.S. EPA.) and the California Air Resources Board (CARB)  
Emission Control System Warranty**

Your Champion Power Equipment (CPE) engine complies with both the U.S. EPA and state of California Air Resources Board (CARB) emission regulations.

**YOUR WARRANTY RIGHTS AND OBLIGATIONS:**

The US EPA, California Air Resources Board, and CPE are pleased to explain the Federal and California Emission Control Systems Warranty on your 2013 small off-road engine and engine powered equipment. In California, new, small off-road engines and new equipment that use small off-engines must be designed, built and equipped to meet the State's stringent anti smog standards. In the other states, new engines and equipment must be designed, built and equipped, at the time of sale, to meet U.S. EPA regulations for small non-road engines. CPE warrants the emission control system on your small off-road engine and equipment for the period of time listed below, provided there has been no abuse, neglect, unapproved modification, or improper maintenance of your equipment.

Your emission control system may include parts such as the carburetor, fuel-injection system, the ignition system, catalytic converter and fuel lines. Also included may be hoses, belts, connectors and other emission related assemblies. Where a warrantable condition exists, CPE will repair your small off-road engine at no cost to you including diagnosis, parts and labor. For engines less than or equal to 80cc, only the fuel tank and fuel line is subject to the evaporative emission control warranty requirements of this section.

**MANUFACTURER'S EMISSION CONTROL SYSTEM WARRANTY COVERAGE:**

This emission control system is warranted for two years, subject to provisions set forth below. If, during the warranty period, emission related part on your engine is defective in materials or workmanship, the part will be repaired or replaced by CPE.

**OWNER WARRANTY RESPONSIBILITIES:**

As the small off-road engine owner, you are responsible for the performance of the required maintenance listed in your Owner's Manual. CPE recommends that you retain all your receipts covering maintenance on your small off-road engine, but CPE cannot deny warranty solely for the lack of receipts or for your failure to ensure the performance of all scheduled maintenance.

As the small off-road engine owner, you should however be aware that CPE may deny you warranty coverage if your small, off-road engine or a part has failed due to abuse, neglect, improper maintenance or unapproved modifications.

You are responsible for presenting your small off-road engine to an Authorized CPE service outlet or alternate service outlet as described in (3)(f.) below, CPE dealer or CPE, Santa Fe Springs, Ca. as soon as a problem exists. The warranty repairs should be completed in a reasonable amount of time, not to exceed 30 days.

If you have any questions regarding your warranty rights and responsibilities, you should contact:

Champion Power Equipment, Inc.  
Customer Service  
10006 Santa Fe Springs Road  
Santa Fe Springs, CA 90670  
1-877-338-0999  
tech@championpowerequipment.com

## **EMISSION CONTROL SYSTEM WARRANTY**

**The following are specific provisions relative to your Emission Control System (ECS) Warranty Coverage.**

**1. APPLICABILITY:** This warranty shall apply to 1995 and later model year California small off-road engines (for other states, 1997 and later model year engines). The ECS Warranty Period shall begin on the date the new engine or equipment is delivered to its original, end-use purchaser, and shall continue for 24 consecutive months thereafter.

### **2. GENERAL EMISSIONS WARRANTY COVERAGE**

CPE warrants to the original, end-use purchaser of the new engine or equipment and to each subsequent purchaser that each of its small off-road engines is:

a. Designed, built and equipped so as to conform to U.S. EPA emissions standards for spark-ignited engines at or below 19 kilowatts and all applicable regulations adopted by the California Air Resources Board and

b. Free from defects in materials and workmanship that cause the failure of a warranted part to be identical in all material respects to the part as described in the engine manufacturer's application for certification for a period of two years.

### **3. THE WARRANTY ON EMISSION-RELATED PARTS WILL BE INTERPRETED AS FOLLOWS:**

a. Any warranted part that is not scheduled for replacement as required maintenance in the Owners Manual shall be warranted for the ECS Warranty Period. If any such part fails during the ECS Warranty Period, it shall be repaired or replaced by CPE according to Subsection "d" below. Any such part repaired or replaced under the ECS Warranty shall be warranted for any remainder of the ECS Warranty Period.

b. Any warranted, emissions-related part which is scheduled only for regular inspection as specified in the Owners Manual shall be warranted for the ECS Warranty Period. A statement in such written instructions to the effect of "repair or replace as necessary", shall not reduce the ECS Warranty Period. Any such part repaired or replaced under the ECS Warranty shall be warranted for the remainder of the ECS Warranty Period.

c. Any warranted, emissions-related part which is scheduled for replacement as required maintenance in the Owner's Manual shall be warranted for the period of time prior to the first scheduled replacement point for that part. If the part fails prior to the first scheduled replacement, the part shall be repaired or replaced by CPE according to Subsection "d" below. Any such emissions-related part repaired or replaced under the ECS Warranty, shall be warranted for the remainder of the ECS Warranty Period prior to the first scheduled replacement point for such emissions-related part.

d. Repair or replacement of any warranted, emissions-related part under this ECS Warranty shall be performed at no charge to the owner at a CPE Authorized Service Outlet.

e. The owner shall not be charged for diagnostic labor which leads to the determination that a part covered by the ECS Warranty is in fact defective, provided that such diagnostic work is performed at a CPE Authorized Service Outlet.

f. CPE shall pay for covered emissions warranty repairs at non-authorized service outlets under the following circumstances:

i. The service is required in a population center with a population over 100,000 according to U.S. Census 2000 without a CPE Authorized Service Outlet AND

ii. The service is required more than 100 miles from a CPE Authorized Service Outlet. The 100 mile limitation does not apply in the following states: Alaska, Arizona, Colorado, Hawaii, Idaho, Montana, Nebraska, Nevada, New Mexico, Oregon, Texas, Utah and Wyoming.

g. CPE shall be liable for damages to other original engine components or approved modifications proximately caused by a failure under warranty of an emission-related part covered by the ECS Warranty.

h. Throughout the ECS Warranty Period, CPE shall maintain a supply of warranted emission-related parts sufficient to meet the expected demand for such emission-related parts.

i. Any CPE Authorized and approved emission-related replacement part may be used in the performance of any ECS Warranty maintenance or repair and will be provided without charge to the owner. Such use shall not reduce CPE's warranty obligation.

j. Unapproved add-on or modified parts may not be used to modify or repair a CPE engine. Such use voids this ECS Warranty and shall be sufficient grounds for disallowing an ECS Warranty claim. CPE shall not be liable hereunder for failures of any warranted parts of a CPE engine caused by the use of such an unapproved add-on or modified part.

**EMISSION-RELATED PARTS INCLUDE THE FOLLOWING: (using those portions of the list applicable to the engine)**

Systems covered by this warranty	Parts Description
Fuel Metering System	Fuel regulator, Carburetor and internal parts
Air Induction System	Air cleaner, Intake manifold
Ignition System	Spark plug and parts, Magneto ignition system
Exhaust System	Exhaust manifold, catalytic converter
Miscellaneous Parts	Tubing, Fittings, Seals, Gaskets, and Clamps associated with these listed systems.
Evaporative Emissions	Fuel Tank, Fuel Cap, Fuel Line, Fuel Line Fittings, Clamps, Pressure Relief Valves, Control Valves, Control Solenoids, Electronic Controls, Vacuum Control Diaphragms, Control Cables, Control Linkages, Purge Valves, Vapor Hoses, Liquid/Vapor Separator, Carbon Canister, Canister Mounting Brackets, Carburetor Purge Port Connector

**TO OBTAIN WARRANTY SERVICE:**

You must take your CPE engine or the product on which it is installed, along with your warranty registration card or other proof of original purchase date, at your expense, to any Champion Power Equipment dealer who is authorized by Champion Power Equipment, Inc. to sell and service that CPE product during his normal business hours. Alternate service locations defined in Section (3)(f.) above must be approved by CPE prior to service. Claims for repair or adjustment found to be caused solely by defects in material or workmanship will not be denied because the engine was not properly maintained and used.

**If you have any questions regarding your warranty rights and responsibilities, or to obtain warranty service, please write or call Customer Service at Champion Power Equipment, Inc.**

**Champion Power Equipment, Inc.  
10006 Santa Fe Springs Road  
Santa Fe Springs, CA 90670  
1-877-338-0999  
Attn.: Customer Service  
tech@championpowerequipment.com**